



Warming Drawer Use & Care Guide



## Contents

- 4 Safety Precautions
- 5 Warming Drawer Features
- 6 Warming Drawer Operation
- 8 Care Recommendations
- 9 Troubleshooting
- 10 Wolf Warranties

## Customer Care

The model and serial number are printed on the enclosed product registration card. Both numbers are also listed on the product rating plate. Refer to page 5 for rating plate location. For warranty purposes, you will also need the date of installation and name of your authorized Wolf dealer. Record this information below for future reference.

If your product ever needs attention, be sure to use a Wolf factory certified service provider recommended by our customer care center, or select one from our list of providers available at [wolfappliance.com/locator](http://wolfappliance.com/locator). All factory certified service providers are carefully selected and thoroughly trained by us.

### SERVICE INFORMATION

Model Number

---

Serial Number

---

Date of Installation

---

Certified Service Name

---

Certified Service Number

---

Authorized Dealer

---

Dealer Number

---

## Important Note

To ensure this product is installed and operated as safely and efficiently as possible, take note of the following types of highlighted information throughout this guide:

**IMPORTANT NOTE** highlights information that is especially important.

**CAUTION** indicates a situation where minor injury or product damage may occur if instructions are not followed.

**WARNING** states a hazard that may cause serious injury or death if precautions are not followed.

**IMPORTANT NOTE:** Throughout this guide, dimensions in parentheses are millimeters unless otherwise specified.

## Thank You

Thank you for your purchase. We look forward to being part of your home for decades to come. As a third-generation family-owned company, we take a very personal stake in the preparation of your family's food. We built our business and our reputation on helping families serve the finest food possible.

With your purchase, you receive one of the strongest warranties in the appliance industry. Take a moment to read the full warranty statement on pages 10–11. It's also important to register your Wolf appliance to ensure that you don't miss out on exclusive owner benefits, such as; assurance that you will be taken care of in the unlikely event that service becomes necessary during the warranty period, and a proof-of-purchase record in case of a home insurance claim. You may register by one of the following options:

- Mail in the completed Wolf product registration card.
- Register online at [wolfappliance.com/register](http://wolfappliance.com/register) and create a personalized My Sub-Zero/ Wolf account using the serial number on your product.
- Register by phone by calling Wolf Customer Care at 800-222-7820.

As a Wolf owner, you can count on ongoing support, day in and day out. Our customer care center is available 24 hours a day, seven days a week and staffed by knowledgeable product experts at our factory in Madison, Wisconsin. Should the need arise, simply call 800-222-7820 and speak with one of our product experts. They will help troubleshoot any issues you might have.

We are confident this guide will answer your questions about the features, operation, and maintenance of your Wolf, but if you have additional questions, please contact us at 800-222-7820 or visit us online at [wolfappliance.com](http://wolfappliance.com).



## **IMPORTANT INSTRUCTIONS**

### **GENERAL SAFETY REQUIREMENTS**

- Read this use & care guide carefully before using your new warming drawer to reduce the risk of fire, electric shock or injury to persons.
- To protect against electrical shock do not immerse cord or plug in water or other liquid.
- The use of accessory attachments not recommended by the appliance manufacturer may cause injuries.
- Do not repair or replace any part of the warming drawer unless specifically recommended in literature accompanying this appliance. All service should be referred to Wolf factory certified service.
- Close supervision is necessary when any appliance is used by or near children.
- Do not use outdoors (model WWD30).
- Do not use appliance for other than intended use.
- Do not touch the heating element or the interior surface of the warming drawer. These surfaces may be hot enough to burn. The inside surfaces of the warming drawer may be hot when opened.
- Do not use aluminum foil to line the warming drawer. This may cause damage to interior surfaces of the warming drawer.

**SAVE THESE INSTRUCTIONS**

## Warming Drawer Features

| FEATURES |                              |
|----------|------------------------------|
| 1        | Product Rating Plate         |
| 2        | Hidden Control Panel         |
| 3        | Removable Rack               |
| 4        | Drawer Pan                   |
| 5        | Full-Extension Drawer Glides |

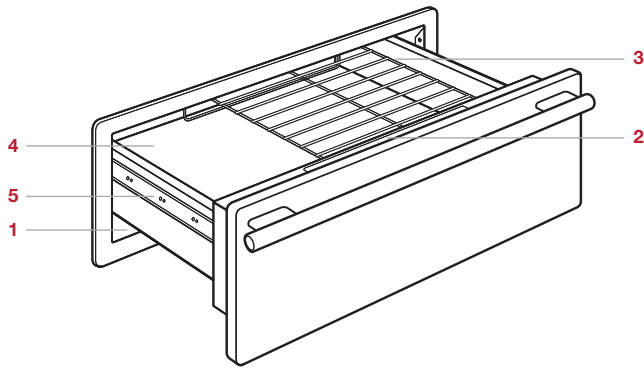

Warming drawer.

## Getting Started

We know you are eager to start cooking, but before you do, please take some time to read this use & care guide. Whether you are an occasional cook or an expert chef, it will be to your benefit to familiarize yourself with the safety practices, features, operation and care recommendations of your warming drawer.

To ensure all residual oil from the manufacturing process has been removed, clean the warming drawer thoroughly with hot water and a mild detergent prior to use. Rinse and dry with a soft cloth. Refer to care recommendations on page 8.

Wolf warming drawers can be used to warm or crisp food, proof dough or warm plates or towels. Model WWD300 is approved for outdoor use.

## Control Panel

The electronic control panel features touch controls and a visual display. Refer to the illustration below. The control panel is hidden when the warming drawer is closed. Open the drawer to access the control panel.

## Temperature

The warming drawer features four preset temperature settings; PROOF, LOW, MED and HIGH. During preheat, the temperature display will alternate between the set point and the actual temperature. 'Lo' will appear until the temperature reaches 85°F (30°C). An audible chime indicates preheat is complete. Refer to the chart below.

### Setting temperature:

- 1 Touch POWER ON/OFF.
- 2 Touch one of the PRESETS to select the preset temperature or touch TEMP UP or DOWN arrows to select the desired temperature.

| TEMPERATURE |              |                    |
|-------------|--------------|--------------------|
| SETTING     | PRESET       | RANGE              |
| PROOF       | 85°F (30°C)  | 80–110°F (25–40°C) |
| LOW         | 120°F (60°C) | 80–200°F (25–95°C) |
| MED         | 160°F (70°C) | 80–200°F (25–95°C) |
| HIGH        | 200°F (95°C) | 80–200°F (25–95°C) |

## Timer

The warming drawer has a built-in timer that will automatically turn off after four hours of use. The timer can be adjusted from one minute to 24 hours.

### Setting timer:

- 1 Select desired temperature.
- 2 Touch TIMER UP or DOWN arrows to select the desired time. 'TIMER' and the shut off time will appear in the display.

## Custom Preset Temperature and Shut Off

Customize a preset temperature setting using desired temperature and timing duration (one minute to 24 hours) with automatic shut off.

### Setting custom preset temperature and automatic shut off:

- 1 Touch POWER ON/OFF.
- 2 Touch and hold the desired preset for 5 seconds until TIMER and '4:00' appear in the display.
- 3 Touch TEMP UP or DOWN arrows to select the desired temperature.
- 4 Touch TEMP UP or DOWN arrows to select the desired automatic shut off timing duration.
- 5 Touch and hold the desired preset again for 5 second to save the settings.

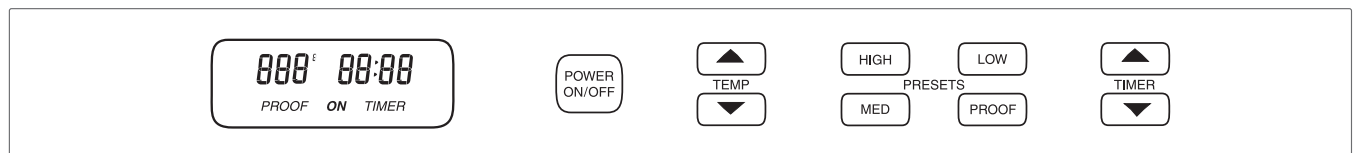

Control panel.



### Extended Options

#### TEMPERATURE UNIT

The warming drawer temperature can be displayed in Fahrenheit or Celsius.

##### Adjusting temperature unit:

- 1 With the warming drawer off, touch and hold the TEMP UP and DOWN arrows for 5 seconds.
- 2 Touch TEMP UP or DOWN arrows to alternate between units.
- 3 Once desired unit is displayed, touch POWER ON/OFF.

#### BACKLIGHT

The warming drawer control panel has three backlight settings; off, on in Sabbath or off in Sabbath.

##### Adjusting backlight:

- 1 With the warming drawer off, touch and hold the TEMP UP and DOWN arrows for 5 seconds.
- 2 Touch TIMER UP or DOWN arrows to alternate between settings.
- 3 Once desired setting is displayed, touch POWER ON/OFF.

### Sabbath

This appliance is certified by Star-K to meet strict religious regulations in conjunction with specific instructions found on [www.star-k.org](http://www.star-k.org).

Sabbath overrides the automatic shut off feature. Sabbath must be reset after a power outage.

##### Setting Sabbath mode:

- 1 Touch and hold POWER ON/OFF until 'Sab' appears on the control panel display.
- 2 Touch one of the PRESETS to select the preset temperature or touch TEMP UP or DOWN arrows to select the desired temperature.
- 3 To cancel, touch POWER ON/OFF.

## Care Recommendations

| CLEANING               |  |
|------------------------|--|
| <b>Stainless steel</b> | <p>Use a nonabrasive stainless steel cleaner and apply with a soft lint-free cloth. To bring out the natural luster, lightly wipe surface with a water-dampened microfiber cloth followed by a dry polishing chamois. Always follow the grain of stainless steel.</p> <p>The stainless steel drawer pan is removable for cleaning. To remove, open drawer completely. Slide fingertips under side edges of pan, pull up and out.</p> |
| <b>Control panel</b>   | <p>Use spray degreaser to remove fingerprints and food soil. Spray on a cloth before wiping panel. Do not spray cleaners directly on the control panel.</p>  |
| <b>Removable Rack</b>  | <p>Clean with hot water and mild detergent or paste of baking soda and water. Towel dry.</p>   |
| <b>Interior</b>        | <p>Wipe with a soft damp cloth. Do not use abrasive or harsh cleaners or scouring pads. For heavier soil, use baking soda or a mild soap; rinse thoroughly with hot water.</p>   |
| <b>Drawer Guides</b>   | <p>Remove food crumbs from drawer guides. Wipe with a soft dry cloth.</p>  |



### Troubleshooting

#### Warming drawer does not operate.

- Verify power is on.
- Verify electrical power to warming drawer and home circuit breaker is on.

#### Drawer does not slide smoothly.

- Drawer is out of alignment. Fully extend the drawer and close completely to realign.
- Drawer is overloaded. Reduce weight to less than 75 lbs (34 kg).
- Redistribute contents to balance load.

#### Excessive condensation.

- Remove liquid in drawer pan.
- Cover food with lid or aluminum foil.
- Temperature setting is too high. Use lower setting.

#### No heat in proof setting.

- Verify PROOF is illuminated on the control panel display.
- Room temperature may prevent thermostat from turning on.

#### Food dries out in proof setting.

- Cover food with lid or aluminum foil.

### SERVICE

- Maintain the quality built into your product by contacting Wolf factory certified service. For the name of the nearest Wolf factory certified service, check the contact & support section of our website, [wolfappliance.com](http://wolfappliance.com) or call Wolf customer care at 800-222-7820.
- When contacting service, you will need the model and serial number of your product. Both numbers are listed on the product rating plate. Refer to page 5 for rating plate location.
- For warranty purposes, you will also need the date of installation and name of your authorized Wolf dealer. This information should be recorded on page 2 of this guide.

## Wolf Appliance Residential Limited Warranty

FOR RESIDENTIAL USE

### FULL TWO YEAR WARRANTY\*

For two years from the date of original installation, this Wolf Appliance product warranty covers all parts and labor to repair or replace, under normal residential use, any part of the product that proves to be defective in materials or workmanship. All service provided by Wolf Appliance under the above warranty must be performed by Wolf factory certified service, unless otherwise specified by Wolf Appliance, Inc. Service will be provided during normal business hours.

### LIMITED FIVE YEAR WARRANTY

For five years from the date of original installation, Wolf Appliance will repair or replace the following parts that prove to be defective in materials or workmanship: gas burners (excludes appearance), electric heating elements, blower motors (ventilation hoods), electronic control boards, magnetron tubes and induction generators. If the owner uses Wolf factory certified service, the service provider will repair or replace these parts with the owner paying for all other costs, including labor. If the owner uses non-certified service, the owner must contact Wolf Appliance, Inc. (using the information below) to receive repaired or replacement parts. Wolf Appliance will not reimburse the owner for parts purchased from non-certified service or other sources.

### TERMS APPLICABLE TO EACH WARRANTY

The warranty applies only to products installed for normal residential use. The warranty applies only to products installed in any one of the fifty states of the United States, the District of Columbia or the ten provinces of Canada. This warranty does not cover any parts or labor to correct any defect caused by negligence, accident or improper use, maintenance, installation, service or repair.

THE REMEDIES DESCRIBED ABOVE FOR EACH WARRANTY ARE THE ONLY ONES THAT WOLF APPLIANCE, INC. WILL PROVIDE, EITHER UNDER THIS WARRANTY OR UNDER ANY WARRANTY ARISING BY OPERATION OF LAW. WOLF APPLIANCE, INC. WILL NOT BE RESPONSIBLE FOR ANY CONSEQUENTIAL OR INCIDENTAL DAMAGES ARISING FROM THE BREACH OF THIS WARRANTY OR ANY OTHER WARRANTY, WHETHER EXPRESS, IMPLIED OR STATUTORY.

Some states do not allow the exclusion or limitation of incidental or consequential damages, so the above limitation or exclusion may not apply to you. This warranty gives you specific legal rights and you may also have other legal rights that vary from state to state.

To receive parts and/or service and the name of Wolf factory certified service nearest you, contact Wolf Appliance, Inc., P.O. Box 44848, Madison, WI 53744; check the contact & support section of our website, [wolfappliance.com](http://wolfappliance.com), email us at [customerservice@subzero.com](mailto:customerservice@subzero.com) or call 800-222-7820.

\*Stainless steel (doors, panels, handles, product frames and interior surfaces) are covered by a limited 60-day parts and labor warranty for cosmetic defects.

\*Replacement filters for ventilation hood recirculating kits are not covered by the product warranty.



## Wolf Appliance Outdoor Limited Warranty\*

### FOR RESIDENTIAL USE

#### FULL ONE YEAR WARRANTY\*\*

For one year from the date of original installation, this Wolf Appliance product warranty covers all parts and labor to repair or replace, under normal residential use, any part of the product that proves to be defective in materials or workmanship. All service provided by Wolf Appliance under the above warranty must be performed by Wolf factory certified service, unless otherwise specified by Wolf Appliance, Inc. Service will be provided during normal business hours.

#### LIMITED FIVE YEAR WARRANTY

For five years from the date of original installation, Wolf Appliance will repair or replace the following parts that prove to be defective in materials or workmanship: stainless steel briquette trays, gas valves, drip pans, electronic control boards and electric heating elements. If the owner uses Wolf factory certified service, the service provider will repair or replace these parts with the owner paying for all other costs, including labor. If the owner uses non-certified service, the owner must contact Wolf Appliance, Inc. (using the information below) to receive repaired or replacement parts. Wolf Appliance will not reimburse the owner for parts purchased from non-certified service or other sources.

#### LIMITED LIFETIME WARRANTY

For the life of the product, Wolf Appliance will repair or replace the following parts that prove to be defective in materials or workmanship: all stainless steel components (excludes surface corrosion, scratches, discoloration, weather and atmospheric related staining and minor surface rust and oxidation). If the owner uses Wolf factory certified service, the service provider will repair or replace these parts with the owner paying for all other costs, including labor. If the owner uses non-certified service, the owner must contact Wolf Appliance, Inc. (using the information below) to receive repaired or replacement parts. Wolf Appliance will not reimburse the owner for parts purchased from non-certified service or other sources.

#### TERMS APPLICABLE TO EACH WARRANTY

The warranty applies only to products installed for normal residential use. The warranty applies only to products installed in any one of the fifty states of the United States, the District of Columbia or the ten provinces of Canada. This warranty does not cover any parts or labor to correct any defect caused by negligence, accident or improper use, maintenance, installation, service or repair.

**THE REMEDIES DESCRIBED ABOVE FOR EACH WARRANTY ARE THE ONLY ONES THAT WOLF APPLIANCE, INC. WILL PROVIDE, EITHER UNDER THIS WARRANTY OR UNDER ANY WARRANTY ARISING BY OPERATION OF LAW. WOLF APPLIANCE, INC. WILL NOT BE RESPONSIBLE FOR ANY CONSEQUENTIAL OR INCIDENTAL DAMAGES ARISING FROM THE BREACH OF THIS WARRANTY OR ANY OTHER WARRANTY, WHETHER EXPRESS, IMPLIED OR STATUTORY.**

Some states do not allow the exclusion or limitation of incidental or consequential damages, so the above limitation or exclusion may not apply to you. This warranty gives you specific legal rights and you may also have other legal rights that vary from state to state.

To receive parts and/or service and the name of Wolf factory certified service nearest you, contact Wolf Appliance, Inc., P.O. Box 44848, Madison, WI 53744; check the contact & support section of our website, [wolfappliance.com](http://wolfappliance.com), email us at [customerservice@subzero.com](mailto:customerservice@subzero.com) or call 800-222-7820.

\*Product must be approved for outdoor use, designated by model and serial number.

\*\*Stainless steel (doors, panels, handles, product frames and interior surfaces) are covered by a limited 60-day parts and labor warranty for cosmetic defects.



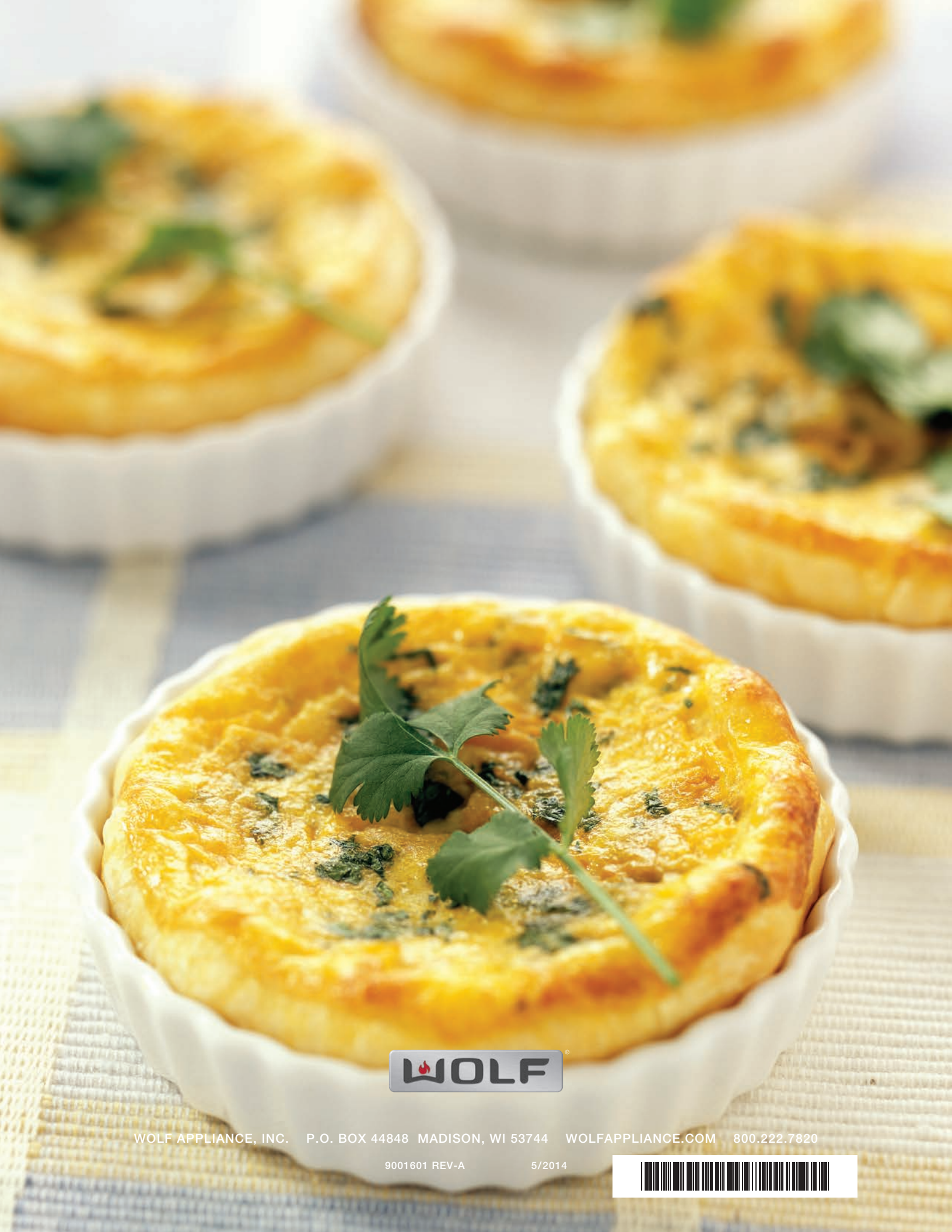

WOLF APPLIANCE, INC. P.O. BOX 44848 MADISON, WI 53744 WOLFAPPLIANCE.COM 800.222.7820

9001601 REV-A

5/2014

