

**ASSEMBLY INSTRUCTIONS**  
**COASTER FINE FURNITURE**



*Fine Furniture for every stage of life*

**181377**  
**SERVING CART**

ITEM:181377



## ASSEMBLY INSTRUCTIONS

### ASSEMBLY TIPS:

1. Remove hardware from box and sort by size.
2. Please check to see that all hardware and parts are present prior to start of assembly.
3. Please follow attached instructions in the same sequence as numbered to assure fast & easy assembly.



### WARNING!

1. Don't attempt to repair or modify parts that are broken or defective. Please contact the store immediately.
2. This product is for home use only and not intended for commercial establishments.

ASSEMBLY TIME

30 MINUTES

## PARTS IDENTIFICATION

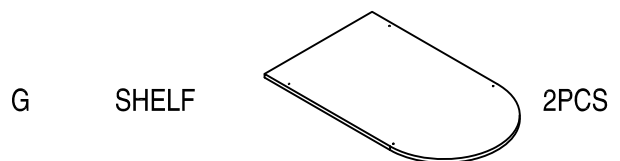
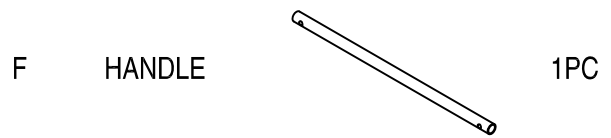
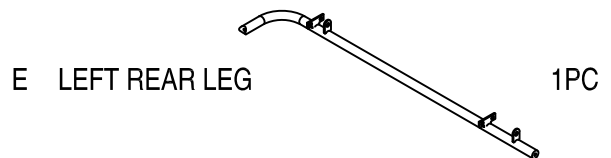
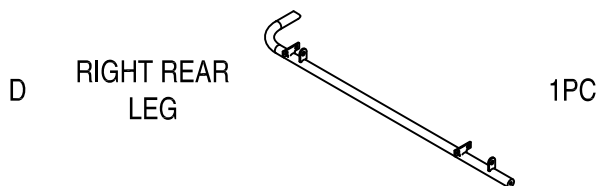
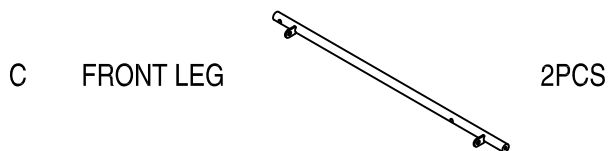
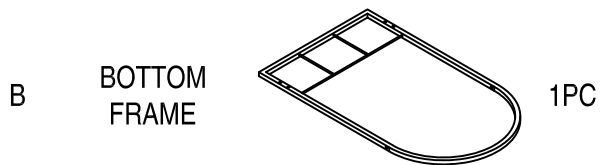
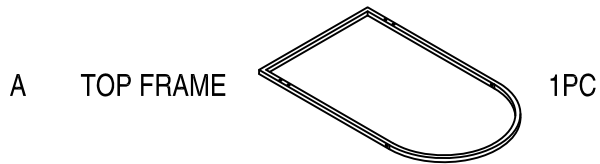

### NOTE:

Phillips head screw driver is required in the assembly process; however, manufacturer does not provide this item.

ITEM: **181377**

## ASSEMBLY INSTRUCTIONS



Z

### HARDWARE IDENTIFICATION

1 ALLEN WRENCH  
(4mm)  1PC

2 WRENCH  1PC

3 BOLT  
(Ø1/4" x 50mm)  2PCS

4 BOLT  
(Ø1/4" x 12mm)  8PCS

5 BOLT  
(Ø1/4" x 25mm)  4PCS

6 SCREW  
(Ø4mm x 9mm)  8PCS

7 CAP  
(Ø3/4")  4PCS

8 WASHER  4PCS

9 CASTER  2PCS

10 CASTER WITH  
LOCK  2PCS

**NOTE:**

Phillips head screw driver is required in the assembly process; however, manufacturer does not provide this item.

ITEM: 181377

## ASSEMBLY INSTRUCTIONS



### STEP 1

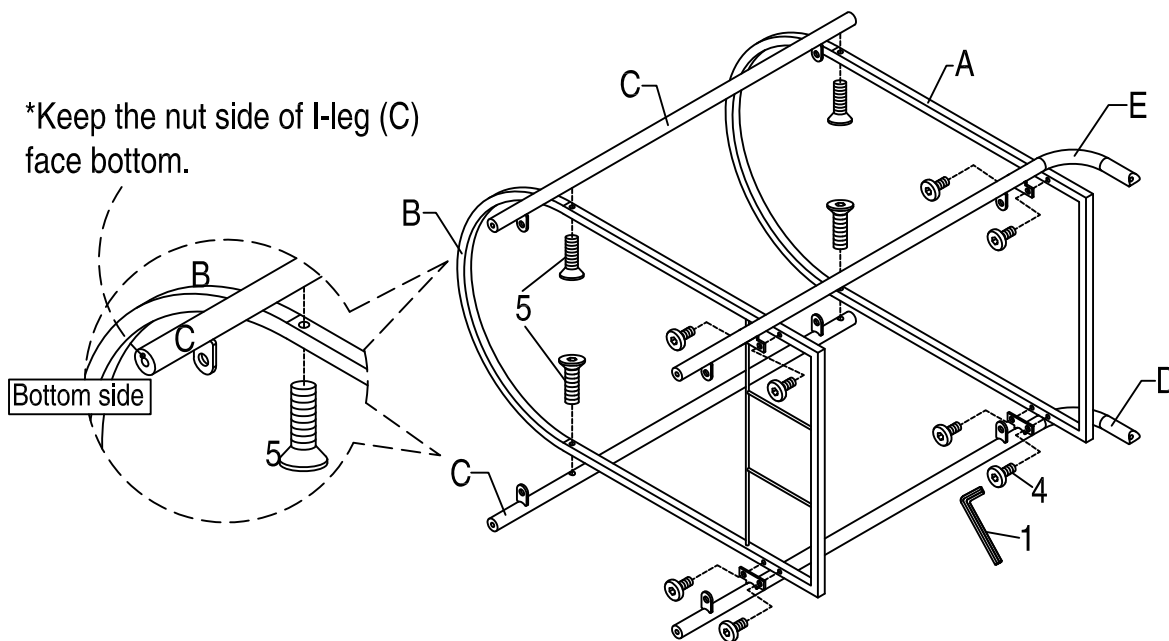

### STEP 2

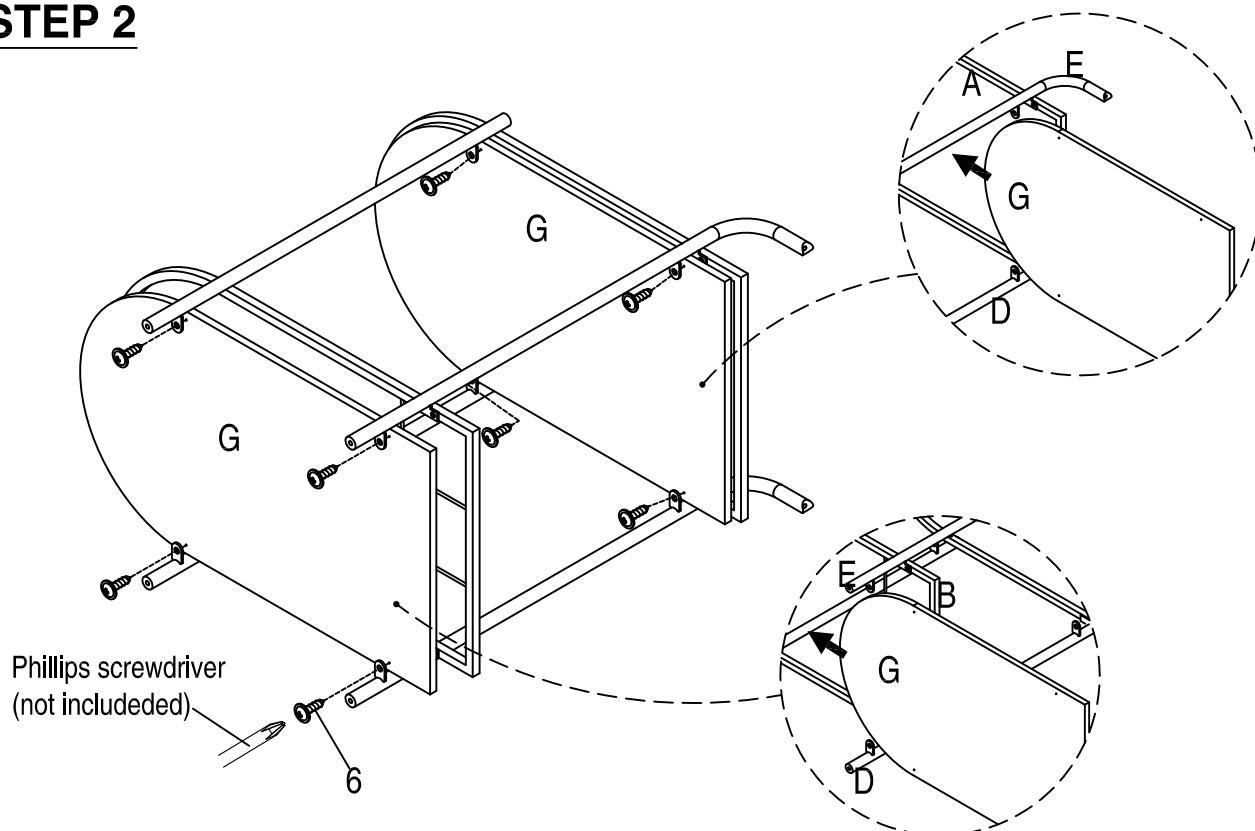

ITEM: 181377

ASSEMBLY INSTRUCTIONS



**STEP 3**

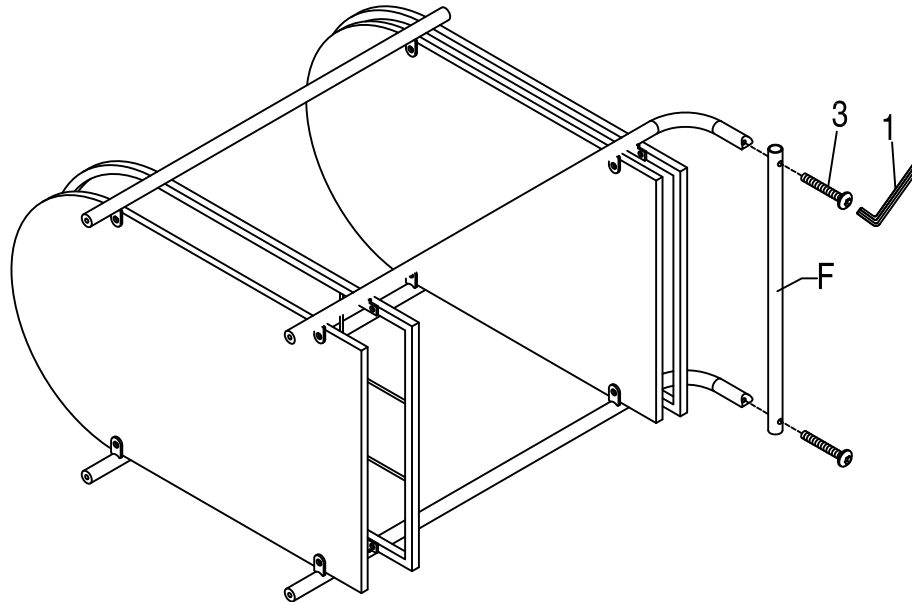

**STEP 4**

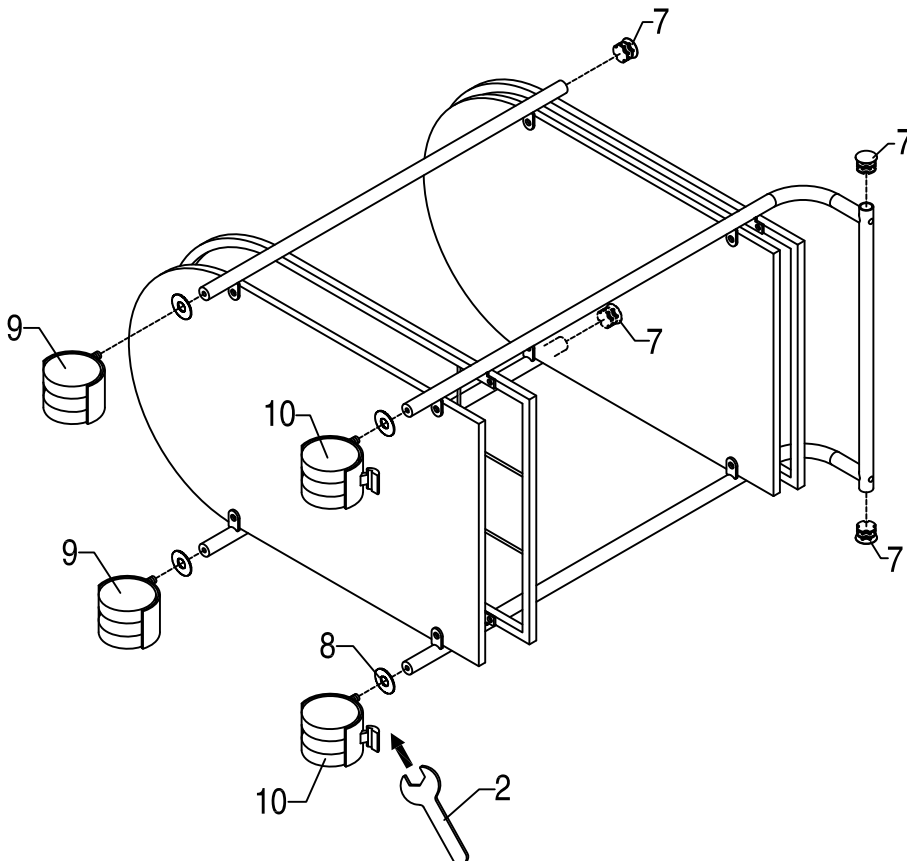

**COMPLETE**

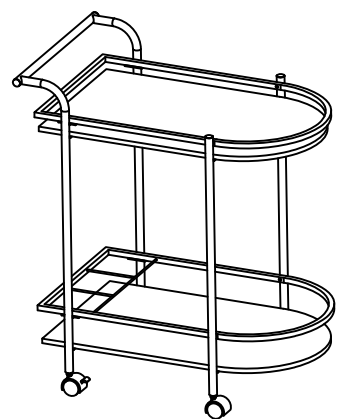

ITEM: 181377

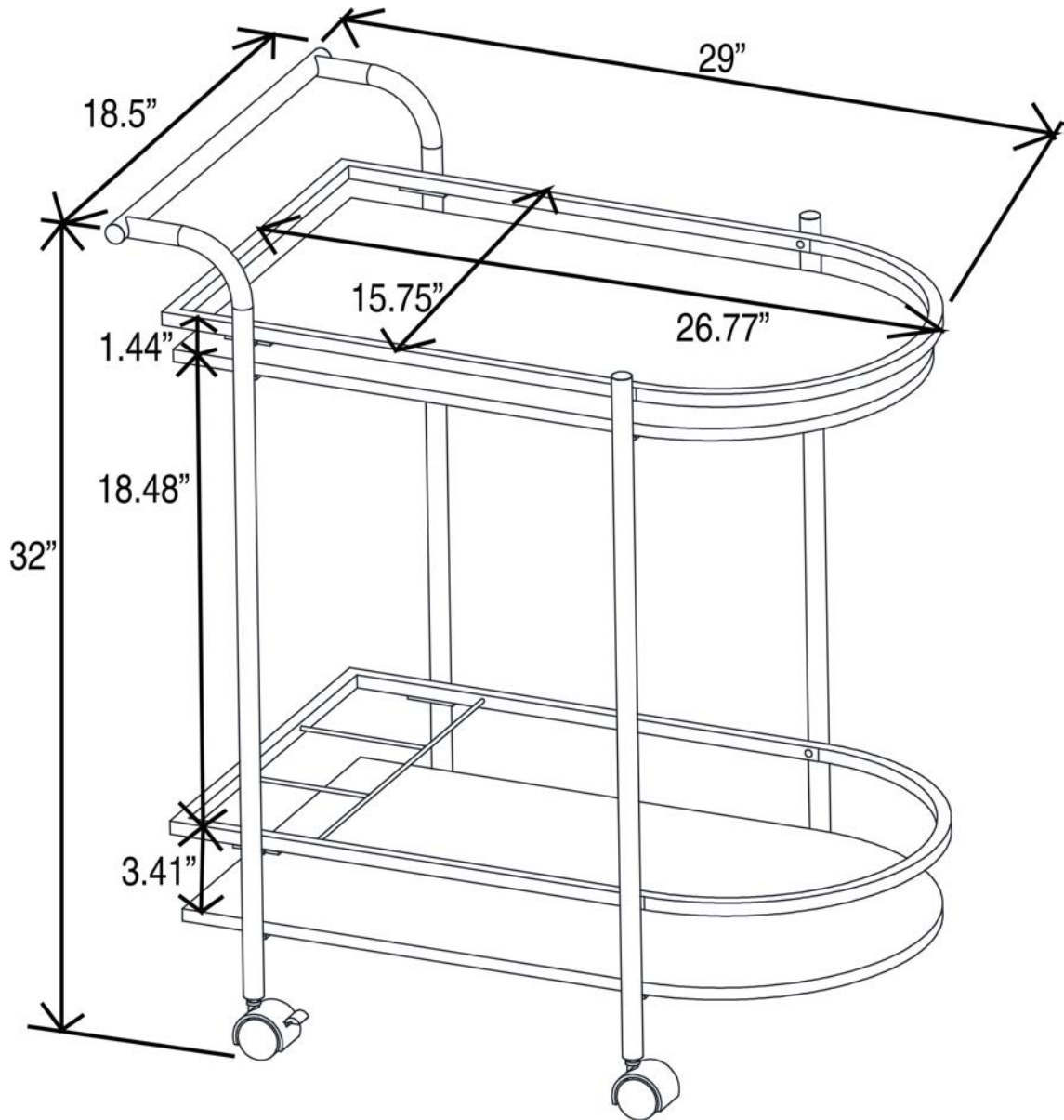

**NOTE:** Dimension tolerance  $\pm 5\%$