

DRYER INSTALLATION INSTRUCTIONS

乾衣機安裝說明

Table of Contents

DRYER SAFETY	2
INSTALLATION REQUIREMENTS.....	4
Tools and Parts	4
LOCATION REQUIREMENTS.....	5
ELECTRICAL REQUIREMENTS.....	7
ELECTRIC DRYER POWER HOOKUP.....	8
GAS DRYER POWER HOOKUP	8
INSTALL LEVELING LEGS.....	10
MAKE ELECTRICAL CONNECTION.....	11
Power Supply Cord.....	11
4-Wire Power Supply Cord Connection.....	12
MAKE GAS CONNECTION.....	15
VENTING.....	16
Venting Requirements.....	16
Plan Vent System	17
Install Vent System.....	18
CONNECT INLET HOSE	19
CONNECT VENT	20
LEVEL DRYER	21
COMPLETE INSTALLATION CHECKLIST.....	21
DOOR REVERSAL (OPTIONAL).....	22

目錄

乾衣機安全.....	28
安裝要求	30
工具與零件	30
地點要求	31
電氣要求	33
電乾衣機的電源連接	34
瓦斯型乾衣機電源連接.....	34
安裝水平支腳.....	36
電氣連接	37
連接電源線 - 直接連接	38
4 線直接電源線連接	38
進行瓦斯連接	41
排氣	42
排氣要求.....	42
設計排氣系統	43
安裝排氣系統	44
連接進水管（僅蒸氣機種）	45
連接排氣管.....	46
放平乾衣機.....	47
完成安裝檢核清單.....	47
把門裝至另一邊（選項）	48

INSTALLATION NOTES / 安裝備註

Date of purchase / 購買日期: _____

Date of installation / 安裝日期: _____

Installer / 安裝人員: _____

Model number / 型號: _____

Serial number / 序號: _____

DRYER SAFETY

Your safety and the safety of others are very important.

We have provided many important safety messages in this manual and on your appliance. Always read and obey all safety messages.



This is the safety alert symbol.

This symbol alerts you to potential hazards that can kill or hurt you and others.

All safety messages will follow the safety alert symbol and either the word "DANGER" or "WARNING."

These words mean:

 **DANGER**

You can be killed or seriously injured if you don't immediately follow instructions.

 **WARNING**

You can be killed or seriously injured if you don't follow instructions.

All safety messages will tell you what the potential hazard is, tell you how to reduce the chance of injury, and tell you what can happen if the instructions are not followed.



WARNING - "Risk of Fire"

- Clothes dryer installation must be performed by a qualified installer.
- Install the clothes dryer according to the manufacturer's instructions and local codes.
- Do not install a clothes dryer with flexible plastic venting materials or flexible metal (foil type) duct. If flexible metal duct is installed, it must be of a specific type identified by the appliance manufacturer as suitable for use with clothes dryers. Flexible venting materials are known to collapse, be easily crushed, and trap lint. These conditions will obstruct clothes dryer airflow and increase the risk of fire.
- To reduce the risk of severe injury or death, follow all installation instructions.
- Save these instructions.

WARNING

Fire Hazard

Failure to follow safety warnings exactly could result in serious injury, death, or property damage.

Do not install a booster fan in the exhaust duct.

Install all clothes dryers in accordance with the installation instructions of the manufacturer of the dryer.

DRYER SAFETY

 **WARNING:**

FIRE OR EXPLOSION HAZARD

Failure to follow safety warnings exactly could result in serious injury, death or property damage.

- Do not store or use gasoline or other flammable vapors and liquids in the vicinity of this or any other appliance.
- **WHAT TO DO IF YOU SMELL GAS:**
 - Do not try to light any appliance.
 - Do not touch any electrical switch; do not use any phone in your building.
 - Clear the room, building, or area of all occupants.
 - Immediately call your gas supplier from a neighbor's phone. Follow the gas supplier's instructions.
 - If you cannot reach your gas supplier, call the fire department.
- Installation and service must be performed by a qualified installer, service agency, or the gas supplier.

WARNING: Gas leaks cannot always be detected by smell.

Gas suppliers recommend that you use a gas detector approved by UL or CSA.

For more information, contact your gas supplier.

If a gas leak is detected, follow the "What to do if you smell gas" instructions.

IMPORTANT: The gas installation must conform with local codes, or in the absence of local codes, with the National Fuel Gas Code, ANSI Z223.1/NFPA 54, or the Natural Gas and Propane Installation Code, CSA B149.1.

The dryer must be electrically grounded in accordance with local codes, or in the absence of local codes, with the National Electrical Code, ANSI/NFPA 70, or the Canadian Electrical Code, Part 1, CSA C22.1.

IMPORTANT SAFETY INSTRUCTIONS

When discarding or storing your old clothes dryer, remove the door.

SAVE THESE INSTRUCTIONS

INSTALLATION REQUIREMENTS

Tools and Parts

Gather the required tools and parts before starting installation.

Tools needed for all installations:

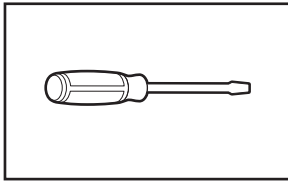

Flat-blade screwdriver

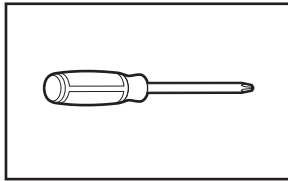

#2 Phillips screwdriver

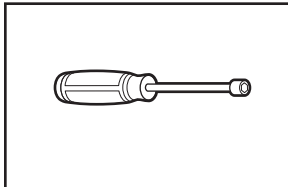

1/4" and 5/16" nut driver (recommended)

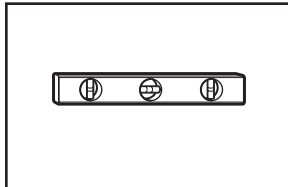

Level

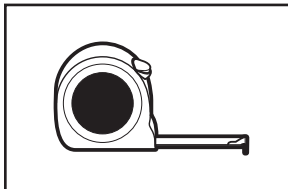

Tape measure

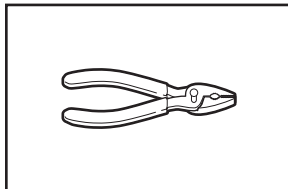

Pliers

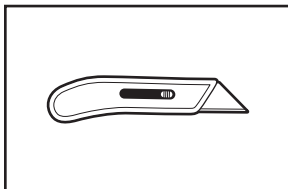

Utility knife

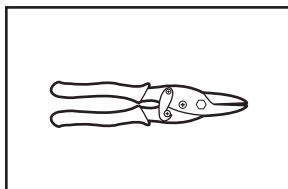

Tin snips (new vent installations)

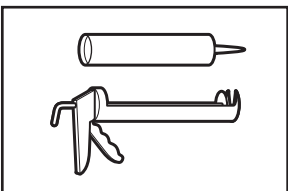

Caulking gun and compound (new vent installations)

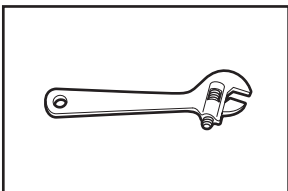

Adjustable wrench that opens to 1" or hex-head socket wrench

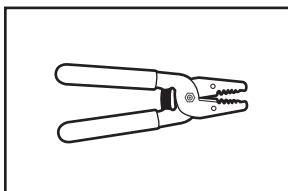

Wire stripper (direct wire installations)

Tools needed for gas installations:

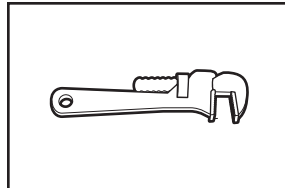

8" or 10" pipe wrench

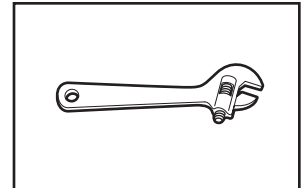

8" or 10" adjustable wrench (for gas connections)

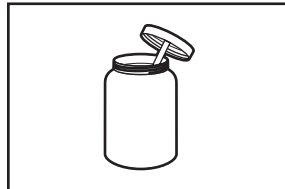

Pipe-joint compound resistant to propane gas

Parts supplied (all models):

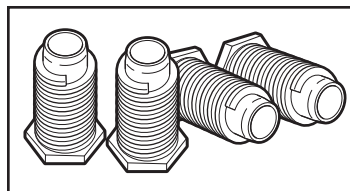

Leveling legs (4)

Parts needed (steam models):

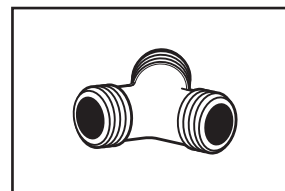

"Y" connector

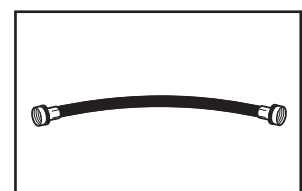

2' inlet hose

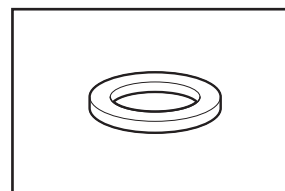

Rubber washer



5' inlet hose

Parts package is located in dryer drum. Check that all parts are included.

NOTE: Do not use leveling legs supplied with dryer if installing with a pedestal or a stack kit.

Parts needed (not supplied with dryer):

- Vent clamps
- Vent elbows and vent work

Additional parts may be required, depending on your installation. Check local codes. Check existing electrical supply and venting. Read "Electrical Requirements" and "Venting Requirements" before purchasing parts.

If using a power supply cord:

Use a UL Listed power supply cord kit marked for use with clothes dryers. The kit should contain:

- A UL Listed 30 A power supply cord, rated 120/240 V minimum. The cord should be type SRD or SRDT and be at least 4 ft. (1.22 m) long. The wires that connect to the dryer must end in ring terminals or spade terminals with upturned ends.
- A UL Listed strain relief.

Optional Equipment (not supplied with dryer):

Refer to your Use and Care Guide for information about accessories available for your dryer.

LOCATION REQUIREMENTS

Check code requirements. Some codes limit, or do not permit, installing dryer in garages, closets, mobile homes, or sleeping quarters. Contact your local building inspector.

⚠ WARNING

Explosion Hazard

Keep flammable materials and vapors, such as gasoline, away from dryer.

Place dryer at least 18 inches (460 mm) above the floor for a garage installation.

Failure to do so can result in death, explosion, or fire.

You will need:

- A location allowing for proper exhaust installation. See "Venting Requirements."
- A separate 15 or 20 A circuit for a gas dryer or 30 A circuit for an electric dryer.
- If using power supply cord, a grounded electrical outlet located within 2 ft. (610 mm) of either side of dryer. See "Electrical Requirements."
- Floor must support dryer weight of 200 lbs. (90.7 kg). Also consider weight of companion appliance.
- Cold water faucets located within 4 ft. (1.2 m) of the water fill valves, and water pressure of 20–120 psi (138–827 kPa). You may use your washer's water supply by purchasing the necessary parts noted in "Parts needed."
- Level floor with maximum slope of 1" (25 mm) under entire dryer. If slope is greater than 1" (25 mm), install Extended Dryer Feet Kit, Part Number 279810. If not level, clothes may not tumble properly and automatic sensor cycles may not operate correctly.
- For garage installation, place dryer at least 18" (460 mm) above floor. If using a pedestal, you will need 18" (460 mm) to bottom of dryer.
- The dryer must not be installed or stored in an area where it will be exposed to water and/or weather.

IMPORTANT: Do not operate, install, or store dryer where it will be exposed to water, weather, or at temperatures below 40°F (4°C). Lower temperatures may cause dryer not to shut off at end of automatic sensor cycles, resulting in longer drying times.

DRYER DIMENSIONS

Front view:

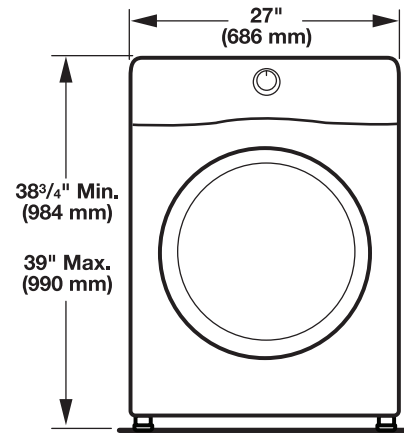

Side view:

Whirlpool Models

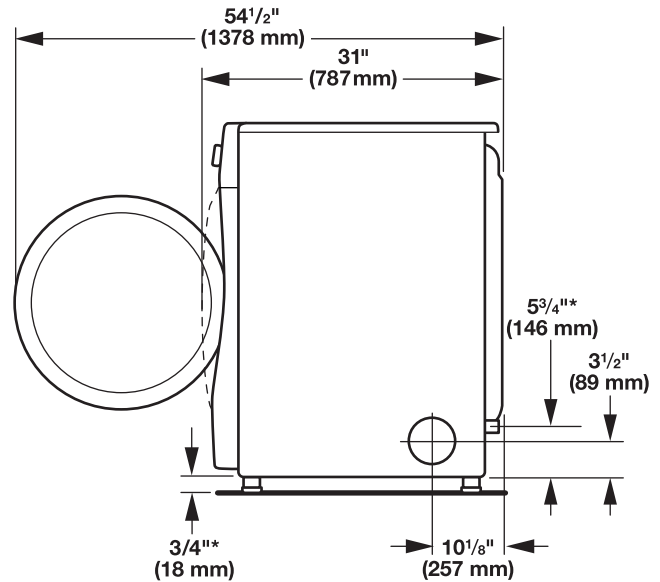

*Approx. measurement

Maytag Models

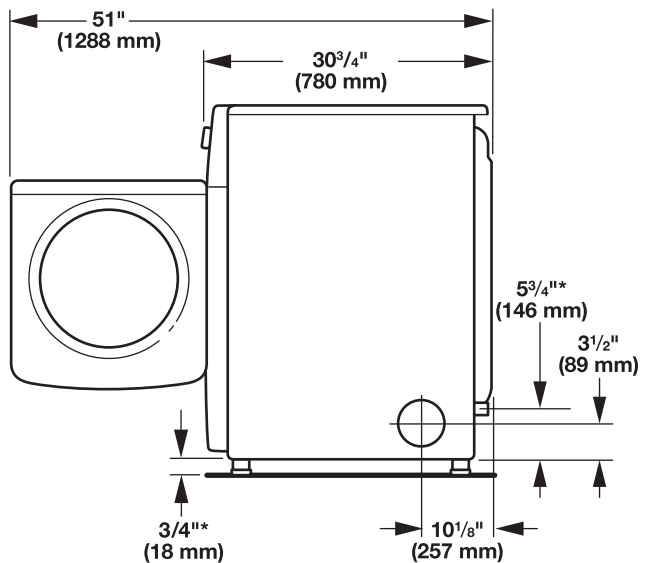

Back view:

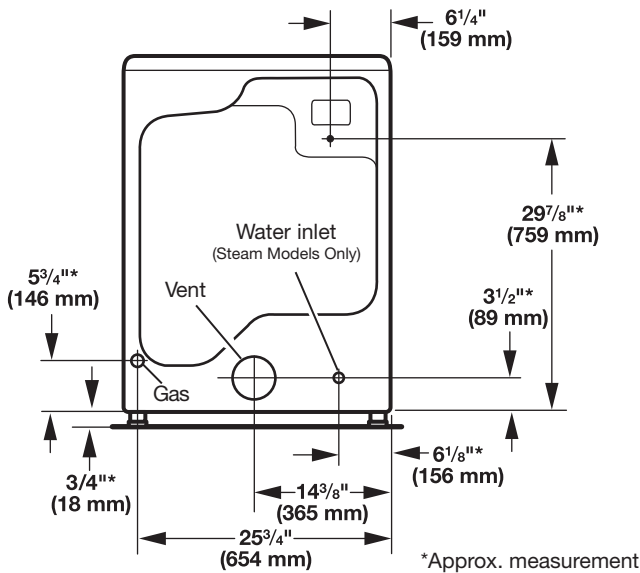

NOTE: Most installations require a minimum of 5" (127 mm) clearance behind dryer for exhaust vent with elbow. See "Venting Requirements."

Installation Clearances

For each arrangement, consider allowing more space for ease of installation and servicing, spacing for companion appliances, and clearances for walls, doors, and floor moldings. Space must be large enough to allow door to fully open. Add spacing on all sides of dryer to reduce noise transfer. If a closet door or louvered door is installed, top and bottom air openings in door are required.

Check code requirements. Some codes limit, or do not permit, installation of the dryer in garages, closets, mobile homes, or sleeping quarters. Contact your local building inspector.

NOTE: No other fuel-burning appliance can be installed in the same closet as a dryer.

Installation spacing for recessed area or closet installation

All dimensions show recommended and minimum spacing allowed.

- Additional spacing should be considered for ease of installation and servicing.
- Additional clearances might be required for wall, door, floor moldings, dryer venting, and gas line.
- Additional spacing should be considered on all sides of the dryer to reduce noise transfer.
- For closet installation with a door, minimum ventilation openings in the top and bottom of the door are required. Louvered doors with equivalent ventilation openings are acceptable.
- Companion appliance spacing should also be considered.

Recommended installation clearances (dryer only):

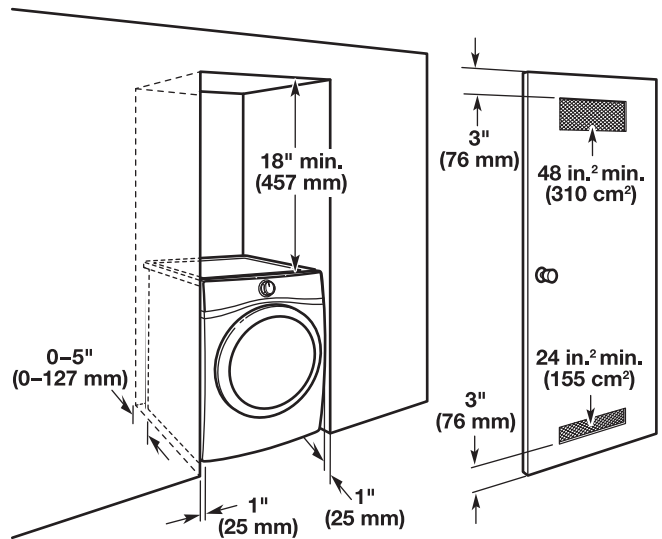

0" (0 mm) rear spacing is allowed for straight back venting only. For steam models only, inlet hose must not be kinked.

Custom under-counter installation:

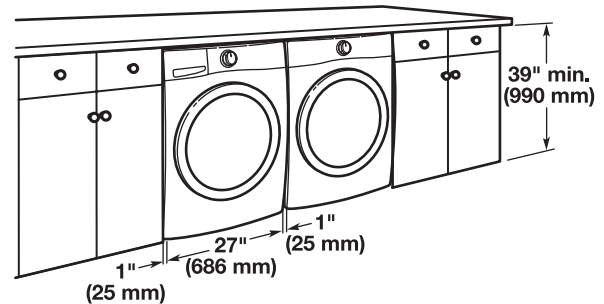

Mobile home – Additional installation requirements:

This dryer is suitable for mobile home installations. The installation must conform to the Manufactured Home Construction and Safety Standard, Title 24 CFR, Part 3280 (formerly the Federal Standard for Mobile home construction and Safety, Title 24, HUD Part 280) or Standard CAN/CSA-Z240 MH.

Mobile home installations require:

- Metal exhaust system hardware, available for purchase from your dealer. For further information, see "Assistance or Service" in your Use and Care Guide.
- Special provisions must be made in mobile homes to introduce outside air into dryer. Openings (such as a nearby window) should be at least twice as large as dryer exhaust opening.

For mobile home installation of gas dryers:

- Mobile Home Installation Hold-down Kit Part Number 346764 is available to order. For further information, see "Assistance or Service" in your Use and Care Guide.

ELECTRICAL REQUIREMENTS

It is your responsibility:

- To contact a qualified electrical installer.
- To supply the required 3 or 4 wire, single-phase, 120/240 V, 60 Hz, AC-only electrical supply (or 3 or 4 wire, 120/208 V electrical supply, if specified on the serial/rating plate) on a separate 30 A circuit, fused on both sides of the line. Connect to an individual branch circuit. Do not have a fuse in the neutral or grounding circuit.
- Do not use an extension cord.
- If codes permit and a separate ground wire is used, it is recommended that a qualified electrician determine that the ground path is adequate.

Electrical Connection

To properly install your dryer, you must determine the type of electrical connection you will be using and follow the instructions provided for it here.

- This dryer is manufactured ready to install with a 4-wire electrical supply connection. To properly install with a 4-wire electrical supply connection the green ground wire of the 4-wire power cord must be secured to the dryer cabinet with the green ground screw. If the dryer is installed with a 3-wire electrical supply connection, a separate external ground connection must be made to the dryer cabinet with the green ground screw.

If using a power supply cord:

Use a UL Listed power supply cord kit marked for use with clothes dryers. The kit should contain:

- A UL Listed 30 A power supply cord, rated 120/240 V minimum. The cord should be type SRD or SRDT and be at least 4 ft. (1.22 m) long. The wires that connect to the dryer must end in ring terminals or spade terminals with upturned ends.
- A UL Listed strain relief.

If your outlet looks like this:



4-wire receptacle
(14-30R)

Then choose a 4-wire power supply cord with ring or spade terminals and UL Listed strain relief. The 4-wire power supply cord, at least 4 ft. (1.22 m) long, must have four 10-gauge copper wires and match a 4-wire receptacle of NEMA Type 14-30R. The ground wire (ground conductor) may be either green or bare. The neutral conductor must be identified by a white cover.



3-wire receptacle
(10-30R)

Then choose a 3-wire power supply cord with ring or spade terminals and UL Listed strain relief. The 3-wire power supply cord, at least 4 ft. (1.22 m) long, must have three 10-gauge copper wires and match a 3-wire receptacle of NEMA Type 10-30R.

NOTE: an external ground conductor must be used in addition to the 3-wire power supply cord, connected to the external ground connector (green screw).

If connecting by direct wire:

Power supply cable must match power supply (4-wire or 3-wire) and be:

- Flexible armored cable or nonmetallic sheathed copper cable (with ground wire), covered with flexible metallic conduit. All current-carrying wires must be insulated.
- 10-gauge solid copper wire or 5.5 mm² stranded wire (do not use aluminum) at least 5 ft. (1.52 m) long.

GROUNDING INSTRUCTIONS

- For a grounded, cord-connected dryer:
This dryer must be grounded. In the event of malfunction or breakdown, grounding will reduce the risk of electric shock by providing a path of least resistance for electric current. This dryer uses a cord having an equipment-grounding conductor and a grounding plug. The plug must be plugged into an appropriate outlet that is properly installed and grounded in accordance with all local codes and ordinances.

- For a permanently connected dryer:
This dryer must be connected to a grounded metal, permanent wiring system, or an equipment-grounding conductor must be run with the circuit conductors and connected to the equipment-grounding terminal or lead on the dryer.

WARNING: Improper connection of the equipment-grounding conductor can result in a risk of electric shock. Check with a qualified electrician or service representative or personnel if you are in doubt as to whether the dryer is properly grounded. Do not modify the plug on the power supply cord: if it will not fit the outlet, have a proper outlet installed by a qualified electrician.

SAVE THESE INSTRUCTIONS

ELECTRIC DRYER POWER HOOKUP

ELECTRICAL REQUIREMENTS

WARNING



Electrical Shock Hazard

Plug into a grounded 4 prong outlet.

Failure to do so can result in death or electrical shock.

It is your responsibility:

- To contact a qualified electrical installer.
- To supply the required 4-wire, single-phase, 120/240 V, 60 Hz, AC-only electrical supply on a separate 30 A circuit, fused on both sides of the line. A time-delay fuse or circuit breaker is recommended. Connect to an individual branch circuit.

For further information, please reference service numbers located in the "Assistance or Service" section of your Use and Care Guide.

GROUNDING INSTRUCTIONS

■ For a grounded, cord-connected dryer:
This dryer must be grounded. In the event of malfunction or breakdown, grounding will reduce the risk of electric shock by providing a path of least resistance for electric current. This dryer is equipped with a cord having an equipment-grounding conductor and a grounding plug. The plug must be plugged into an appropriate outlet that is properly installed and grounded in accordance with all local codes and ordinances.

WARNING: Improper connection of the equipment-grounding conductor can result in a risk of electric shock. Check with a qualified electrician or service representative or personnel if you are in doubt as to whether the dryer is properly grounded. Do not modify the plug provided with the dryer: if it will not fit the outlet, have a proper outlet installed by a qualified electrician.

SAVE THESE INSTRUCTIONS

GAS DRYER POWER HOOKUP

ELECTRICAL REQUIREMENTS

WARNING



Electrical Shock Hazard

Plug into a grounded 3 prong outlet.

Do not remove ground prong.

Do not use an adapter.

Do not use an extension cord.

Failure to follow these instructions can result in death, fire, or electrical shock.

- 120 V, 60 Hz, AC-only, 15 or 20 A fused electrical supply is required. A time-delay fuse or circuit breaker is recommended. It is also recommended that a separate circuit serving only this dryer be provided.

GROUNDING INSTRUCTIONS

■ For a grounded, cord-connected dryer:
This dryer must be grounded. In the event of malfunction or breakdown, grounding will reduce the risk of electric shock by providing a path of least resistance for electric current. This dryer is equipped with a cord having an equipment-grounding conductor and a grounding plug. The plug must be plugged into an appropriate outlet that is properly installed and grounded in accordance with all local codes and ordinances.

WARNING: Improper connection of the equipment-grounding conductor can result in a risk of electric shock. Check with a qualified electrician or service representative or personnel if you are in doubt as to whether the dryer is properly grounded. Do not modify the plug provided with the dryer: if it will not fit the outlet, have a proper outlet installed by a qualified electrician.

SAVE THESE INSTRUCTIONS

GAS SUPPLY REQUIREMENTS

⚠ WARNING



Explosion Hazard

Use a new CNS approved gas supply line.

Install a shut-off valve.

Securely tighten all gas connections.

If connected to propane, have a qualified person make sure gas pressure does not exceed 13" (33 cm) water column.

Examples of a qualified person include:
licensed heating personnel,
authorized gas company personnel, and
authorized service personnel.

Failure to do so can result in death, explosion, or fire.

GAS TYPE

Natural Gas:

This dryer is equipped for use with natural gas. It is certified by UL for use with propane gas with appropriate conversion.

- Your dryer must have the correct burner for the type of gas in your home. Burner information is located on the rating plate in the door well of your dryer. If this information does not agree with the type of gas available, contact your dealer or call the phone numbers referenced in the "Assistance or Service" section of your Use and Care Guide.

Propane Gas Conversion:

IMPORTANT: Conversion must be made by a qualified technician.

No attempt shall be made to convert the appliance from the gas specified on the model/serial rating plate for use with a different gas without consulting your gas company.

GAS SUPPLY LINE

Option 1 (Recommended Method)

Flexible stainless steel gas connector:

- If local codes permit, use a new flexible stainless steel gas connector (Design Certified by the American Gas Association or CSA International) to connect your dryer to the rigid gas supply line. Use an elbow and a 3/8" flare x 3/8" NPT adapter fitting between the stainless steel gas connector and the dryer gas pipe, as needed, to prevent kinking.

Option 2 (Alternate Method)

Approved aluminum or copper tubing:

- Must include 1/8" NPT minimum plugged tapping accessible for test gauge connection, immediately upstream of the gas connection to the dryer. See illustration below.
- 1/2" IPS pipe is recommended.
- 3/8" approved aluminum or copper tubing is acceptable for lengths under 20 ft. (6.1 m) if local codes and gas supplier permit.
- If you are using natural gas, do not use copper tubing.
- Lengths over 20 ft. (6.1 m) should use larger tubing and a different size adapter fitting.
If your dryer has been converted to use propane gas, 3/8" propane compatible copper tubing can be used. If the total length of the supply line is more than 20 ft. (6.1 m), use larger pipe.
NOTE: Pipe-joint compounds that resist the action of propane gas must be used. Do not use TEFLON[†] tape.
- Must include shut-off valve.

In the U.S.A.:

An individual manual shut-off valve must be installed within six (6) ft. (1.8 m) of the dryer in accordance with the National Fuel Gas Code, ANSI Z223.1. The location should be easy to reach for opening and closing.

In Canada:

An individual manual shut-off valve must be installed in accordance with the B149.1, Natural Gas and Propane Installation Code. It is recommended that an individual manual shut-off valve be installed within six (6) ft. (1.8 m) of the dryer. The location should be easy to reach for opening and closing.

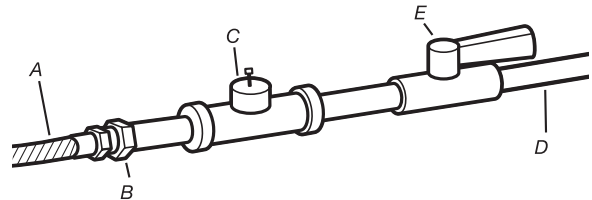

- A. 3/8" flexible gas connector
- B. 3/8" pipe to flare adapter fitting
- C. 1/8" NPT minimum plugged tapping
- D. 1/2" NPT gas supply line
- E. Gas shut-off valve

[†]TEFLON is a registered trademark of Chemours.

GAS SUPPLY CONNECTION REQUIREMENTS

- Use an elbow and a 3/8" flare x 3/8" NPT adapter fitting between the flexible gas connector and the dryer gas pipe, as needed to avoid kinking.
- Use only pipe-joint compound. Do not use TEFLON tape.
- This dryer must be connected to the gas supply line with a listed flexible gas connector that complies with the standard for connectors for gas appliances, ANSI Z21.24 or CSA 6.10.

BURNER INPUT REQUIREMENTS

Elevations above 2,000 ft. (610 m):

- When installed above 2,000 ft. (610 m) a 4% reduction of the burner Btu rating shown on the model/serial number plate is required for each 1,000 ft. (305 m) increase in elevation.

Gas supply pressure testing

- The dryer must be disconnected from the gas supply piping system during pressure testing at pressures greater than 1/2 psi.

DRYER GAS PIPE

- The gas pipe that comes out through the rear of your dryer has a 3/8" male pipe thread.

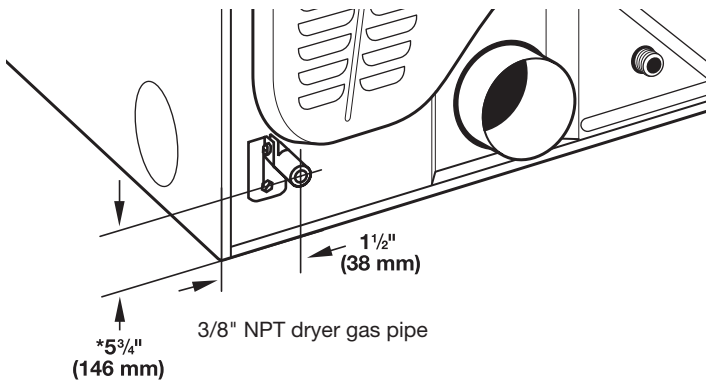

***NOTE:** If the dryer is mounted on a pedestal, the gas pipe height must be an additional 10" (254 mm) or 15.5" (394 mm) from the floor, depending on the pedestal model. For a garage installation, the gas pipe height must be an additional 18" (460 mm) from the floor.

INSTALL LEVELING LEGS

⚠ WARNING

Excessive Weight Hazard

Use two or more people to move and install dryer.

Failure to do so can result in back or other injury.

1. Prepare dryer for leveling legs

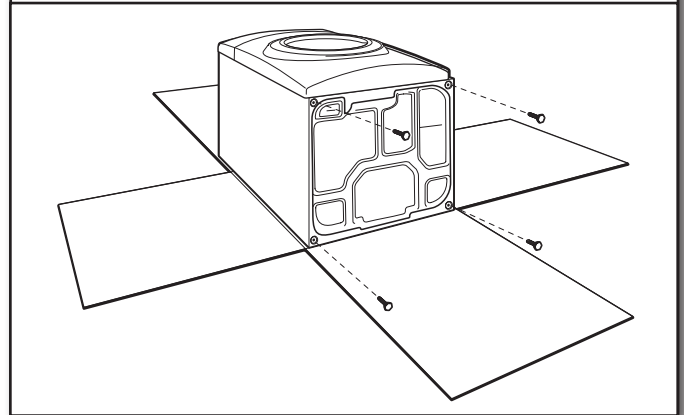

To avoid damaging floor, use a large flat piece of cardboard from dryer carton; place under entire back edge of dryer. Firmly grasp dryer body (not console panel) and gently lay dryer down on cardboard.

2. Screw in leveling legs

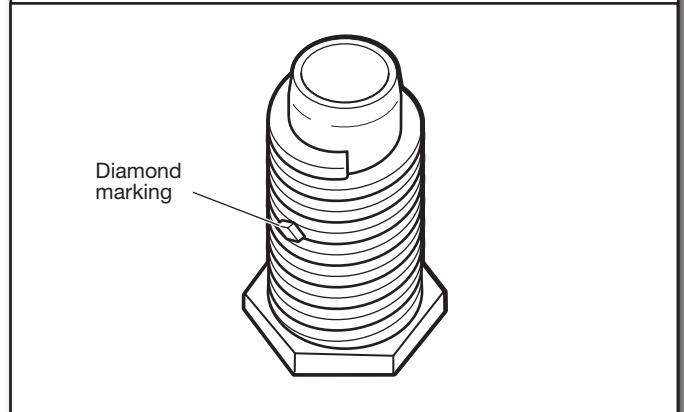

Examine leveling legs and locate the diamond marking. Screw legs into leg holes by hand – use a wrench to finish turning legs until diamond marking is no longer visible.

Place a carton corner post from dryer packaging under each of the two dryer back corners. Stand the dryer up. Slide the dryer on the corner posts until it is close to its final location. Leave enough room to connect the exhaust vent.

MAKE ELECTRICAL CONNECTION

ELECTRICAL CONNECTION

Power Supply Cord:

WARNING



Fire Hazard

- Use a new UL listed 30 amp power supply cord.
- Use a UL listed strain relief.
- Disconnect power before making electrical connections.
- Connect neutral wire (white or center wire) to center terminal (silver).
- Ground wire (green or bare wire) must be connected to green ground connector.
- Connect remaining 2 supply wires to remaining 2 terminals (gold).
- Securely tighten all electrical connections.
- Failure to do so can result in death, fire, or electrical shock.

Before you start: disconnect power.

1. Choose electrical connection type



Power supply cord 4-wire receptacle (NEMA Type 14-30R).
Go to "Power Supply Cord Connection."



Power supply cord 3-wire receptacle (NEMA Type 10-30R).
Go to "Power Supply Cord Connection."



4-wire direct connection:
Go to "Direct Wire Connection."



3-wire direct connection:
Go to "Direct Wire Connection."

NOTE: If Local codes do not permit connection of a cabinet-ground conductor to neutral wire; go to "3-Wire Connection with External Ground." This connection must be used with either a power supply cord or a direct wire connection.

For direct wire installations:

WARNING



Fire Hazard

- Use 10 gauge copper wire.
- Use a UL listed strain relief.
- Disconnect power before making electrical connections.
- Connect neutral wire (white or center wire) to center terminal (silver).
- Ground wire (green or bare wire) must be connected to green ground connector.
- Connect remaining 2 supply wires to remaining 2 terminals (gold).
- Securely tighten all electrical connections.
- Failure to do so can result in death, fire, or electrical shock.

2. Remove terminal block cover

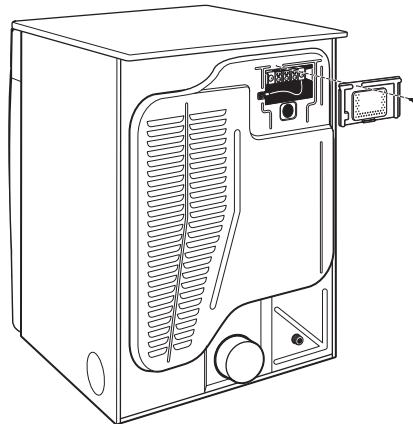

Remove hold-down screw and terminal block cover.

Power Supply Cord Connection

Power supply cord strain relief

1. Attach power supply cord strain relief

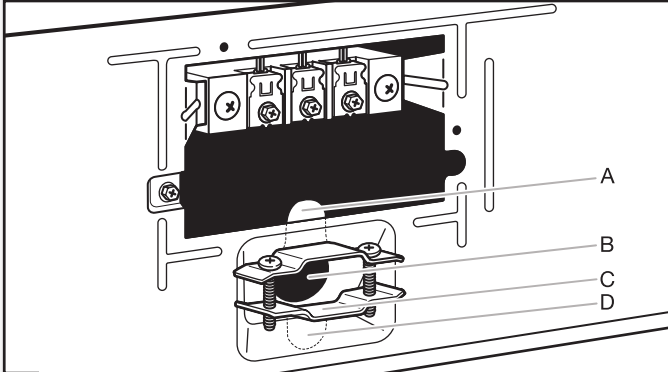

Remove the screws from a 3/4" (19 mm) UL Listed strain relief. Put the tabs of the two clamp sections (C) into the hole below the terminal block opening (B) so that one tab is pointing up (A) and the other is pointing down (D), and hold in place. Tighten strain relief screws just enough to hold the two clamp sections (C) together.

2. Attach power supply cord to strain relief

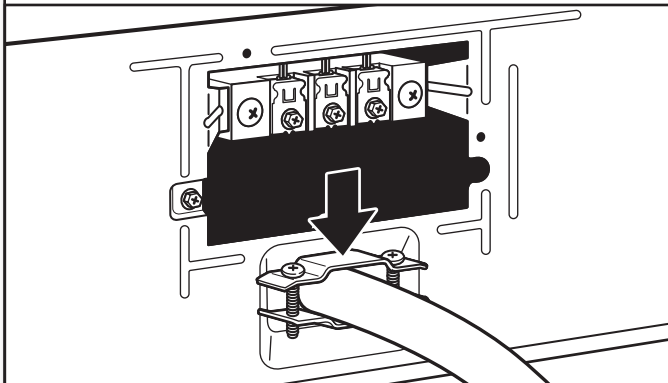

Put power supply cord through the strain relief. Be sure that the wire insulation on the power supply cord is inside the strain relief. The strain relief should have a tight fit with the dryer cabinet and be in a horizontal position. Do not further tighten strain relief screws at this point.

If your outlet looks like this:



Power supply cord 4-wire receptacle (NEMA Type 14-30R):
Go to "4-Wire Power Supply Cord Connection" on this page.



Power supply cord 3-wire receptacle (NEMA Type 10-30R):
Go to "3-Wire Power Supply Cord Connection" on page 13.

4-Wire Power Supply Cord Connection

IMPORTANT: A 4-wire connection is required for mobile homes and where local codes do not permit the use of 3-wire connections.

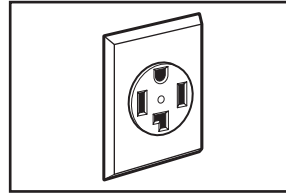

4-wire receptacle (NEMA type 14-30R)

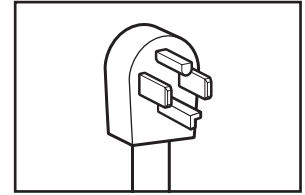

4 prong plug

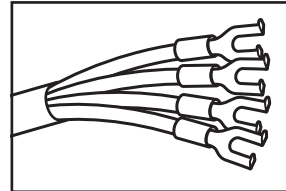

Spade terminals with upturned ends

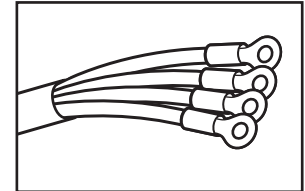

Ring terminals

1. Connect ground wire

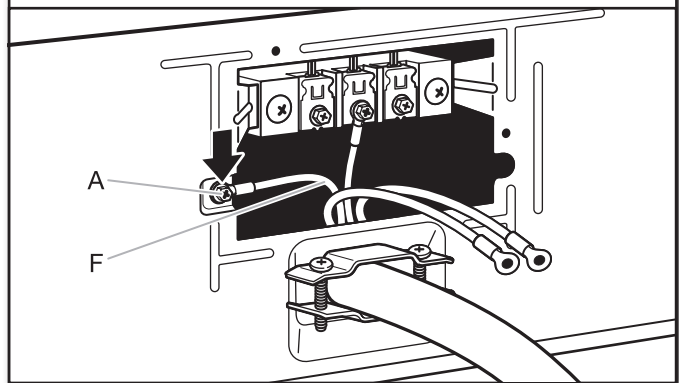

Connect ground wire (F) (green or bare) of power supply cord under green external ground conductor screw (A). Tighten screw.

2. Connect remaining wires

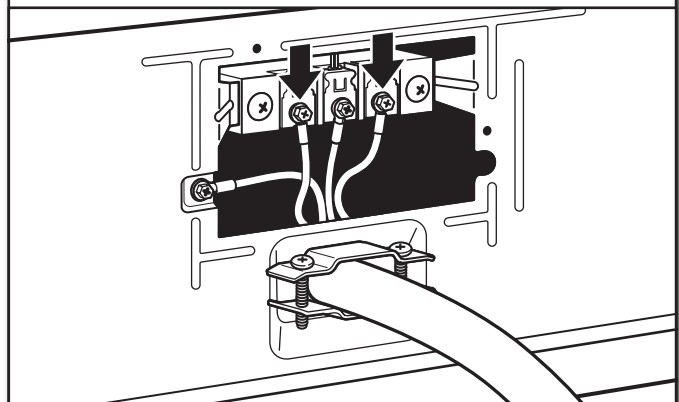

Connect remaining wires under outer terminal block screws. Tighten screws. Finally, reinsert tab of terminal block cover into slot of dryer rear panel. Secure cover with hold-down screw. Now go to "Venting Requirements."

Direct Wire Connection

Direct wire strain relief

1. Attach direct wire strain relief

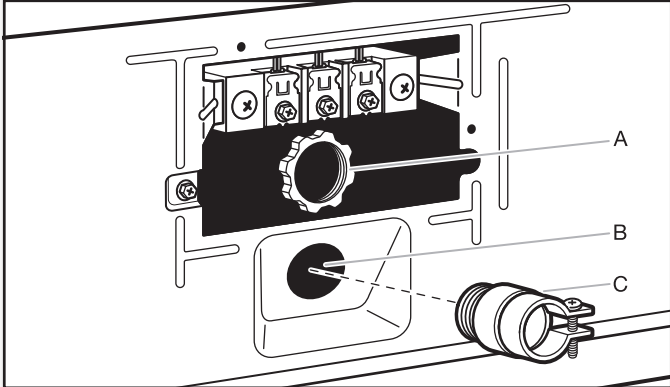

Unscrew the removable conduit connector (A) and any screws from a 3/4" (19 mm) UL Listed strain relief. Put the threaded section of the strain relief (C) through the hole below the terminal block opening (B). Reaching inside the terminal block opening, screw the removable conduit connector (A) onto the strain relief threads and tighten securely.

2. Attach direct wire cable to strain relief

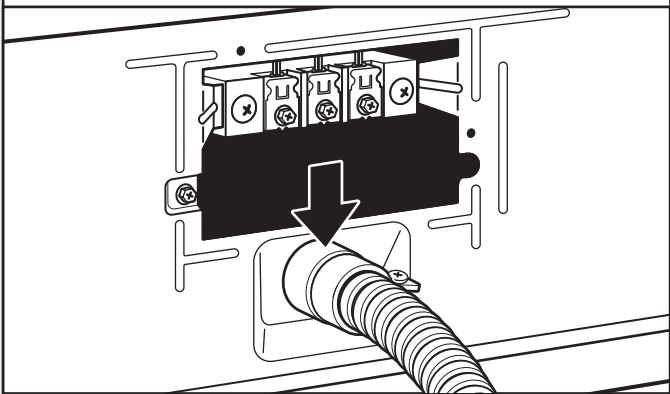

Put direct wire cable through the strain relief. The strain relief should have a tight fit with the dryer cabinet and be in a horizontal position. Tighten strain relief screw against the direct wire cable.

If your wiring looks like this:



4-wire direct connection:
Go to "4-Wire Direct Wire Connection"
on this page.

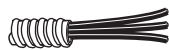

3-wire direct connection:
Go to "3-Wire Direct Wire Connection".

4-Wire Direct Wire Connection

IMPORTANT: A 4-wire connection is required for mobile homes and where local codes do not permit 3-wire connections.

1. Prepare your 4-wire cable for direct connection

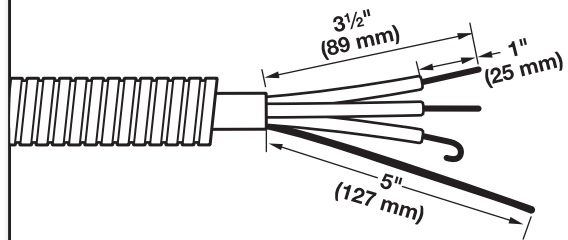

Direct wire cable must have 5 ft. (1.52 m) of extra length so dryer may be moved if needed.

Strip 5" (127 mm) of outer covering from end of cable, leaving bare ground wire at 5" (127 mm). Cut 1 1/2" (38 mm) from remaining three wires. Strip insulation back 1" (25 mm). Shape ends of wires into hooks.

2. Connect neutral wire

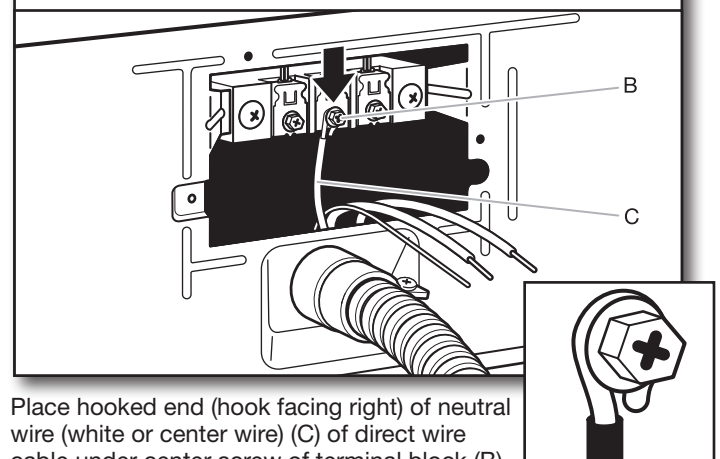

Place hooked end (hook facing right) of neutral wire (white or center wire) (C) of direct wire cable under center screw of terminal block (B). Squeeze hooked ends together and tighten screw.

3. Connect ground wire

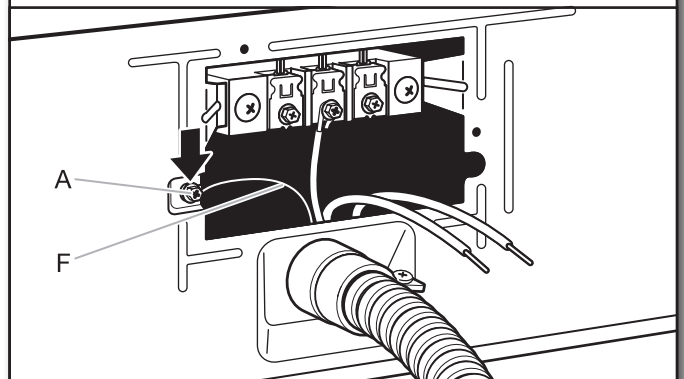

Connect ground wire (green or bare) (F) of direct wire cable under green external ground conductor screw (A). Tighten screw.

4. Connect remaining wires

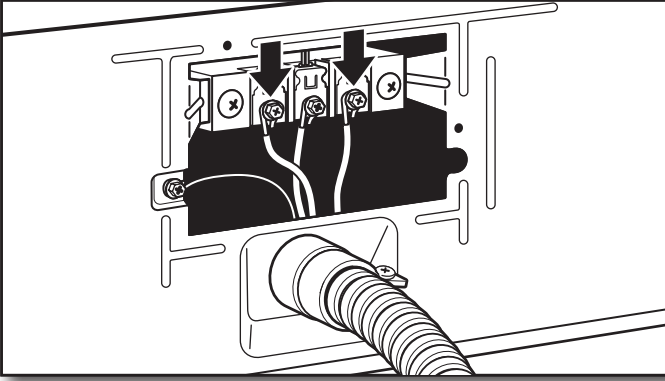

Place hooked ends of remaining direct wire cable wires under outer terminal block screws (hooks facing right). Squeeze hooked ends together and tighten screws. Finally, reinsert tab of terminal block cover into slot of dryer rear panel. Secure cover with hold-down screw. Now go to "Venting Requirements."

3-Wire Connection with External Ground Connection (Power Supply Cord Shown)

IMPORTANT: You must verify with a qualified electrician that this grounding method is acceptable before connecting. If a 3-wire connection necessary, an external ground wire must be connected per the following instructions.

1. Prepare to connect neutral wire

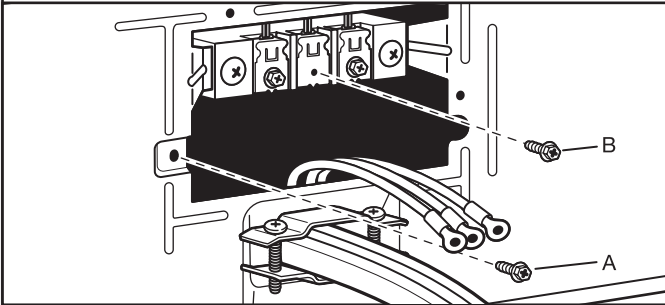

Install the correct strain relief for your electrical connection method, as shown on page 13.

Remove center terminal block screw (B). Remove green external ground conductor screw (A).

2. Connect neutral wire

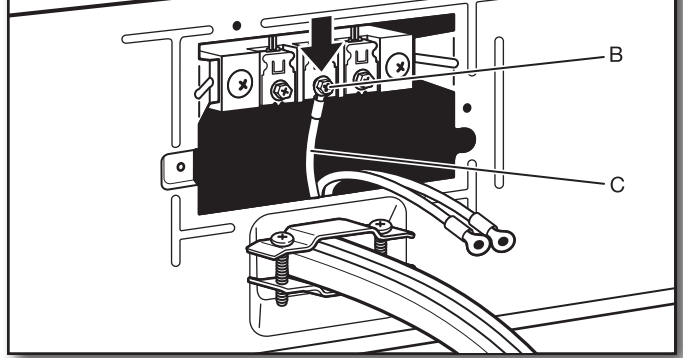

Connect neutral wire (white or center wire) (C) of power supply cord or cable under center terminal block screw (B). Tighten screw.

3. Connect remaining wires

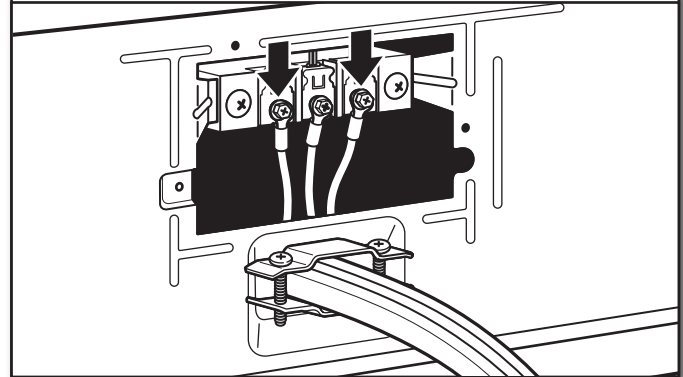

Place ends of remaining wires under outer terminal block screws. Tighten screws.

4. Connect external ground wire

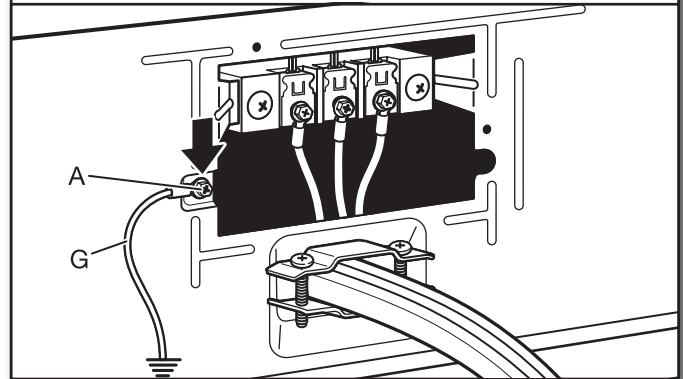

Connect a separate copper ground wire (G) under the green external ground conductor screw (A) to an adequate ground. Finally, reinsert tab of terminal block cover into slot of dryer rear panel. Secure cover with hold-down screw. Now go to "Venting Requirements."

MAKE GAS CONNECTION

(Gas models only)

⚠ WARNING



Explosion Hazard

Use a new CNS approved gas supply line.

Install a shut-off valve.

Securely tighten all gas connections.

If connected to propane, have a qualified person make sure gas pressure does not exceed 13" (33 cm) water column.

Examples of a qualified person include:

licensed heating personnel,
authorized gas company personnel, and
authorized service personnel.

Failure to do so can result in death, explosion, or fire.

1. Connect gas supply to dryer

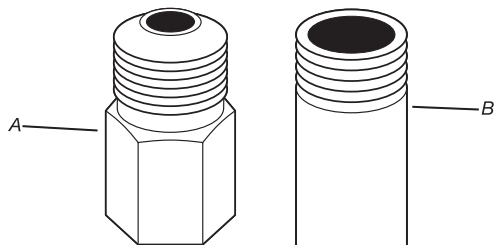

A. Flared male fitting
B. Non-flared male fitting

Remove red cap from gas pipe. Using a wrench to tighten, connect gas supply to dryer. Use pipe-joint compound on threads of all non-flared male fittings. If flexible metal tubing is used, be sure there are no kinks.

NOTE: For propane gas connections, you must use pipe-joint compound resistant to action of propane gas. Do not use TEFLON tape.

2. Plan pipe fitting connection (Option 1)

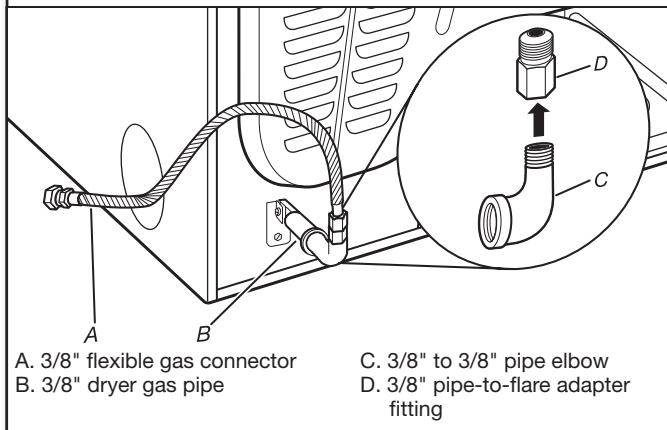

A. 3/8" flexible gas connector
B. 3/8" dryer gas pipe
C. 3/8" to 3/8" pipe elbow
D. 3/8" pipe-to-flare adapter fitting

A combination of pipe fittings must be used to connect dryer to existing gas line. A recommended connection is shown. Your connection may be different, according to supply line type, size, and location.

3. Open shut-off valve

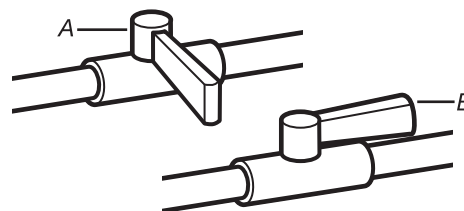

A. Closed valve
B. Open valve

Open shut-off valve in supply line; valve is open when handle is parallel to gas pipe. Then, test all connections by brushing on an approved noncorrosive leak-detection solution. Bubbles will show a leak. Correct any leak found.

VENTING

Venting Requirements

⚠ WARNING



Fire Hazard

- Use a heavy metal vent.**
- Do not use a plastic vent.**
- Do not use a metal foil vent.**

Failure to follow these instructions can result in death or fire.

WARNING: To reduce the risk of fire, this dryer MUST BE EXHAUSTED OUTDOORS.

IMPORTANT: Observe all governing codes and ordinances. Dryer exhaust must not be connected into any gas vent, chimney, wall, ceiling, attic, crawlspace, or a concealed space of a building. Only rigid or flexible metal vent shall be used for exhausting.

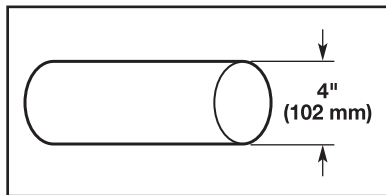

4" (102 mm) heavy metal exhaust vent

- Only a 4" (102 mm) heavy metal exhaust vent and clamps may be used.
- Do not use plastic or metal foil vent.

Rigid metal vent:

- Recommended for best drying performance and to avoid crushing and kinking.

Flexible metal vent: (Acceptable only if accessible to clean)

- Must be fully extended and supported in final dryer location.
- Remove excess to avoid sagging and kinking that may result in reduced airflow and poor performance.
- Do not install in enclosed walls, ceilings, or floors.
- The total length should not exceed 7¼ ft. (2.4 m).
- The length of flexible metal vent used must be included in the overall vent system design as shown in the "Vent System Charts."

NOTE: If using an existing vent system, clean lint from entire length of the system and make sure exhaust hood is not plugged with lint. Replace plastic or metal foil vents with rigid metal or flexible metal vents. Review "Vent System Charts" and, if necessary, modify existing vent system to achieve best drying performance.

Exhaust hoods:

- An exhaust hood should cap the vent to keep rodents and insects from entering the home.
- Must be at least 12" (305 mm) from ground or any object that may obstruct exhaust (such as flowers, rocks, bushes, or snow).
- Do not use an exhaust hood with a magnetic latch.

Recommended Styles:

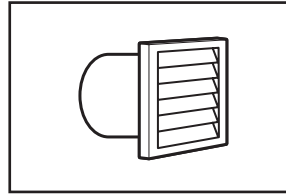

Louvered Hood

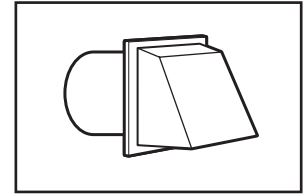

Box Hood

Acceptable Style:

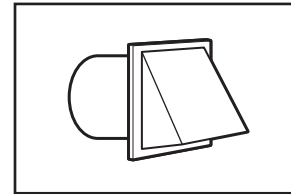

Angled Hood

Elbows:

45° elbows provide better airflow than 90° elbows.

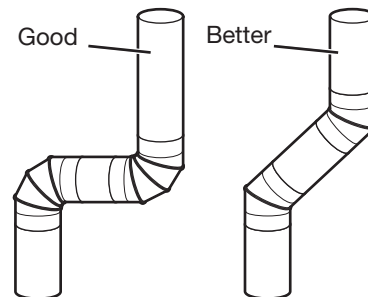

Clamps:

- Use clamps to seal all joints.
- Exhaust vent must not be connected or secured with screws or other fastening devices that extend into interior of duct and catch lint. Do not use duct tape.

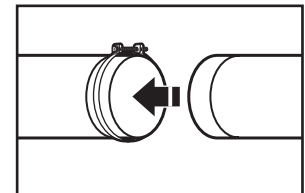
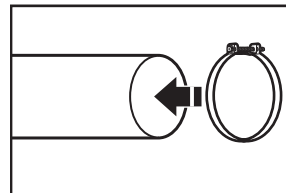

Plan Vent System

Recommended exhaust installation:

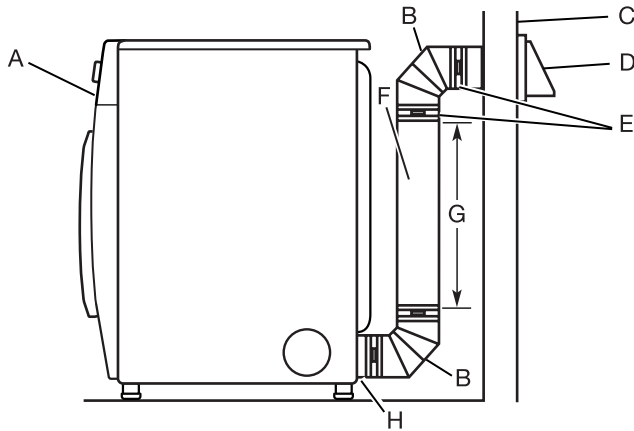

- A. Dryer
- B. Elbow
- C. Wall
- D. Exhaust hood
- E. Clamps
- F. Rigid metal or flexible metal vent
- G. Vent length necessary to connect elbows
- H. Exhaust outlet

Determine vent path:

- Select route that will provide straightest and most direct path outdoors.
- Plan installation to use fewest number of elbows and turns.
- When using elbows or making turns, allow as much room as possible.
- Bend vent gradually to avoid kinking.
- Use as few 90° turns as possible.

Determine vent length and elbows needed for best drying performance:

- Use the following “Vent System Charts” to determine type of vent material and hood combinations acceptable to use.

NOTE: Do not use vent runs longer than those specified in “Vent System Charts.”

Exhaust systems longer than those specified will:

- Shorten life of dryer.
- Reduce performance, resulting in longer drying times and increased energy usage.

The “Vent System Charts” provide venting requirements that will help achieve best drying performance.

Standard Vent System Chart

Number of 90° elbows	Type of vent	Angled hoods
0	Rigid metal	64 ft. (20 m)
1	Rigid metal	54 ft. (16.5 m)
2	Rigid metal	44 ft. (13.4 m)
3	Rigid metal	35 ft. (10.7 m)
4	Rigid metal	27 ft. (8.2 m)

⚠ WARNING



Fire Hazard

Cover unused exhaust holes with a manufacturer's exhaust cover kit.

Contact your local dealer.

Failure to follow these instructions can result in death, fire, electrical shock, or serious injury.

Optional exhaust installations:

This dryer can be converted to exhaust out the right side, left side (all models except long vent), or through the bottom. If you prefer, you may contact your local dealer to have the dryer converted.

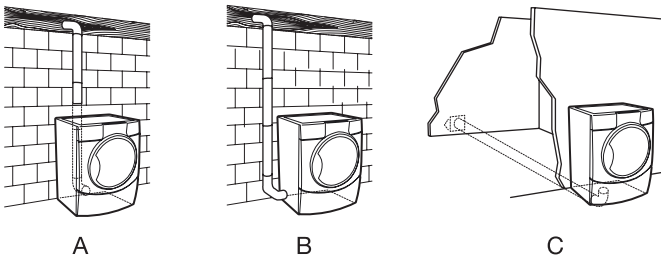

- A. Standard rear offset exhaust installation
- B. Left- or right-side exhaust installation
- C. Bottom exhaust installation

Long Vent System Chart

Number of 90° elbows	Type of vent	Angled hoods
0	Rigid metal	160 ft. (48.8 m)
1	Rigid metal	150 ft. (45.7 m)
2	Rigid metal	140 ft. (42.7 m)
3	Rigid metal	130 ft. (39.6 m)
4	Rigid metal	120 ft. (36.6 m)

To determine if your model has a long vent system, refer to the type code located on the serial number plate in the inner door well. Example: An electric model would be **DALV** – ELE – XXXXXXXX-XXX. A gas model would be **DALV** – NAT – XXXXXXXX-XXX.

NOTE: For long vent systems, use of box/louvered hoods will improve venting regardless of length.

Install Vent System

1. Install exhaust hood

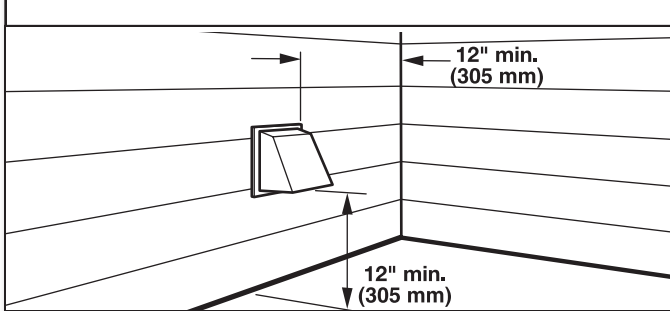

Install exhaust hood and use caulking compound to seal exterior wall opening around exhaust hood.

2. Connect vent to exhaust hood

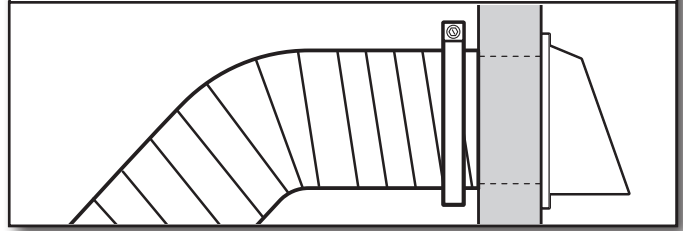

Vent must fit over the exhaust hood. Secure vent to exhaust hood with 4" (102 mm) clamp. Run vent to dryer location using straightest path possible. Avoid 90° turns. Use clamps to seal all joints. Do not use duct tape, screws, or other fastening devices that extend into interior of vent to secure vent, because they can catch lint.

CONNECT INLET HOSE (STEAM MODEL ONLY)

For non-steam models, skip to “Connect Vent.”

The dryer must be connected to the cold water faucet using the new inlet hoses (not supplied). Do not use old hoses.

NOTE: Replace inlet hoses after 5 years of use to reduce the risk of hose failure. Record hose installation or replacement dates on the hoses for future reference.

Periodically inspect and replace hoses if bulges, kinks, cuts, wear, or leaks are found.

1. Turn cold water off, remove hose, and replace rubber washer

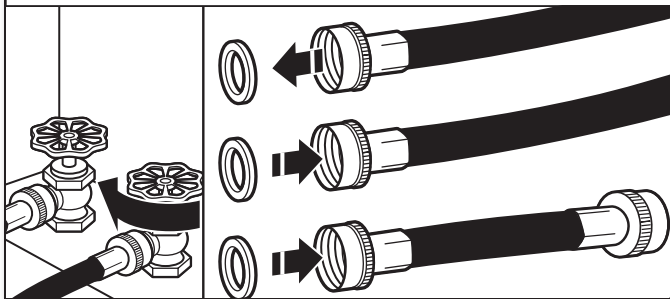

Turn cold water faucet off and remove washer inlet hose. Remove old rubber washer from inlet hose and replace with new rubber washer.

2. Attach short hose and “Y” connector

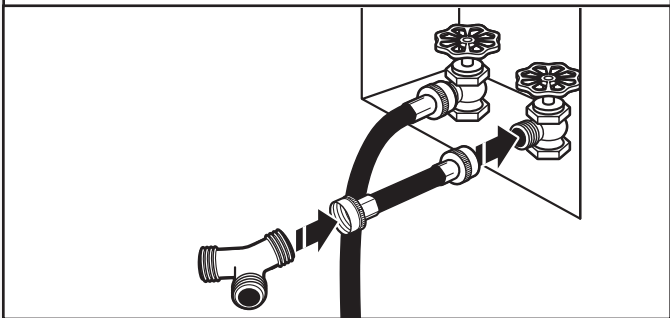

Attach 2 ft. (0.6 m) inlet hose to cold water faucet. Screw on coupling by hand until it is seated on faucet. Then attach “Y” connector to male end of the 2 ft. (0.6 m) inlet hose. Screw on coupling by hand until it is seated on connector.

3. Tighten couplings

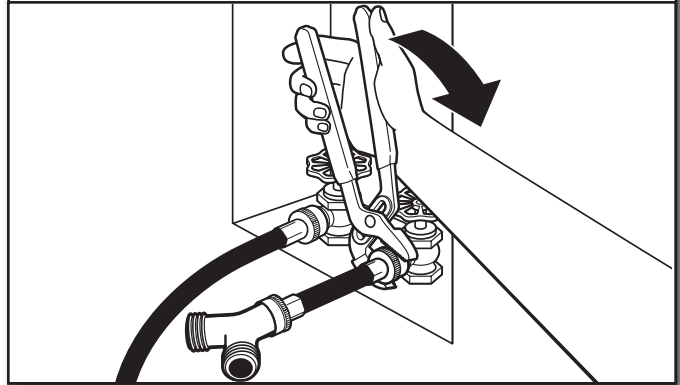

Using pliers, tighten the couplings with additional 2/3 turn.

NOTE: Do not overtighten. Damage to the coupling can result.

4. Attach long hose to “Y” connector and tighten couplings

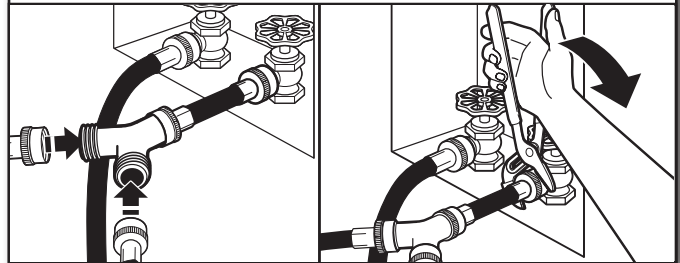

Attach one of the 5 ft. (1.5 m) inlet hose ends to the “Y” connector. Attach washer cold inlet hose to other side of “Y” connector. Screw on coupling by hand until it is seated on connector. Using pliers, tighten the couplings an additional 2/3 turn.

NOTE: Do not overtighten. Damage to the coupling can result.

5. Attach long hose to dryer fill valve and tighten coupling

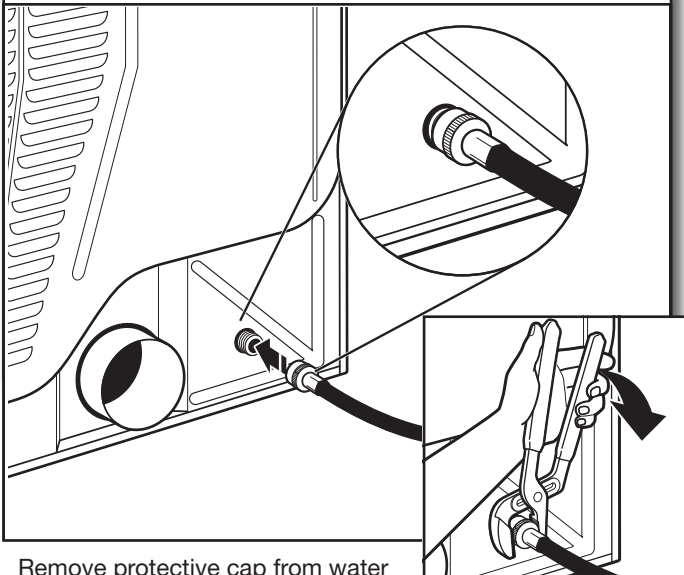

Remove protective cap from water inlet valve. Attach other end of long hose to fill valve at bottom of dryer back panel. Screw on coupling by hand until it is seated on fill valve connector. Using pliers, tighten the couplings an additional 2/3 turn.

NOTE: Do not overtighten. Damage to the coupling can result.

6. Turn on cold water faucet

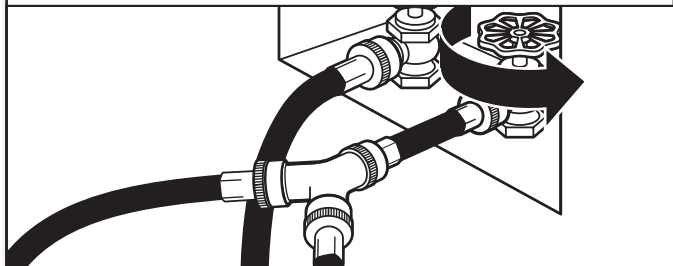

Check that the water faucets are turned on.

7. Check for leaks

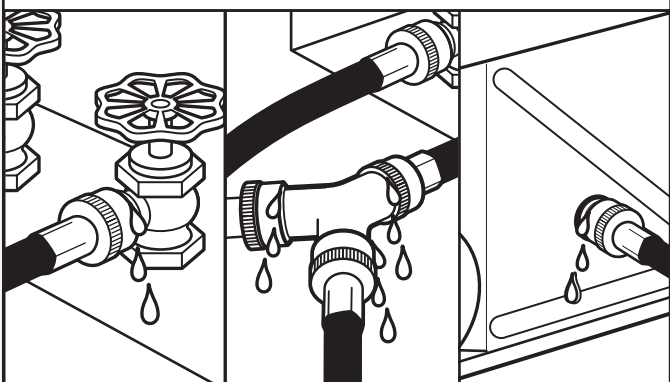

Check for leaks around "Y" connector, faucet, and hoses.

CONNECT VENT

1. Connect vent to exhaust outlet

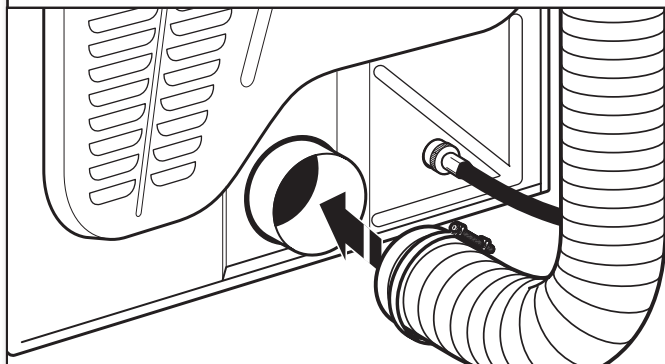

Using a 4" (102 mm) clamp, connect vent to exhaust outlet in dryer. If connecting to existing vent, make sure vent is clean. Dryer vent must fit over dryer exhaust outlet and inside exhaust hood. Check that vent is secured to exhaust hood with a 4" (102 mm) clamp.

2. Move dryer to final location

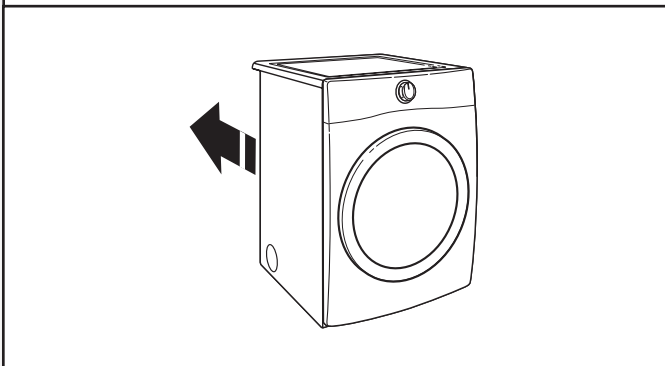

Move dryer to final location, taking care not to crush or kink vent or flexible gas line.

After dryer is in place, remove corner posts and cardboard from under dryer.

LEVEL DRYER

1. Level dryer

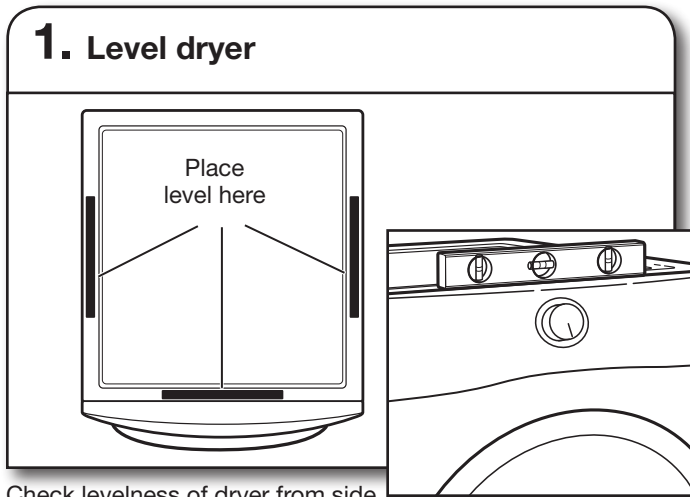

Check levelness of dryer from side to side. Repeat from front to back.

NOTE: The dryer must be level for the moisture sensing system to operate correctly.

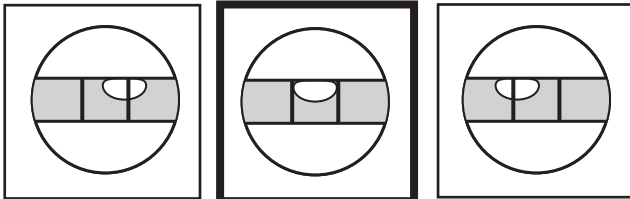

Not Level

LEVEL

Not Level

2. Adjust leveling legs

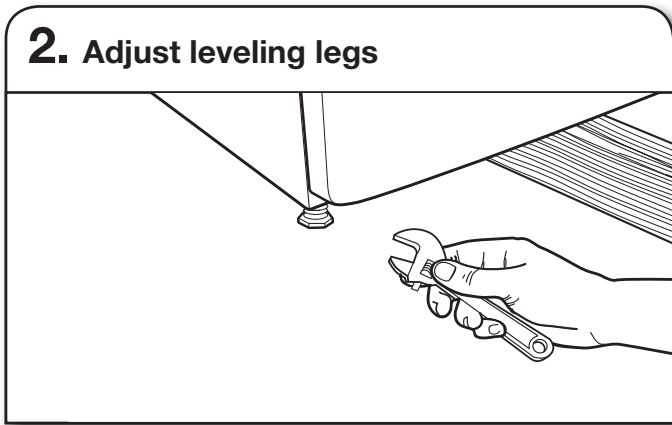

If dryer is not level, prop up using a wood block, use wrench to adjust legs up or down, and check again for levelness. Once dryer is level, make sure all four legs are snug against the floor and the dryer does not rock.

COMPLETE INSTALLATION CHECKLIST

- Check that all parts are now installed. If there is an extra part, go back through steps to see what was skipped.
- Check that you have all of your tools.
- Dispose of/recycle all packaging materials.
- Be sure the water faucets are on.
- Check for leaks around “Y” connector, faucet, and hoses.
- Check dryer’s final location. Be sure vent is not crushed or kinked.
- Check that dryer is level. See “Level Dryer.”
- Remove film on console and any tape remaining on dryer.
- Wipe dryer drum interior thoroughly with a damp cloth to remove any dust.
- Read “Dryer Use” in your Use and Care Guide.
- If you live in a hard water area, use of a water softener is recommended to control the build-up of scale through the water system in the dryer. Over time, the build-up of lime scale may clog different parts of the water system, which will reduce product performance. Excessive scale build-up may lead to the need for certain part replacement or repair.

Electric Models:

- Plug into a grounded outlet.

Gas Models:

- Plug into a grounded outlet.
- Check that gas supply is on.
- Check for leaks.
- Check to be sure that the flexible gas line is not crushed or kinked.

All Models:

- Select a Timed Dry heated cycle and start dryer. Do not select Air Only Temperature setting.

If dryer will not start, check the following:

- Controls are set in a running or On position.
- Start button has been pressed firmly.
- Dryer is plugged into an outlet and/or electrical supply is connected.
- Household fuse is intact and tight, or circuit breaker has not tripped.
- Dryer door is closed.

This dryer automatically runs an installation diagnostic routine at the start of its first cycle.

NOTE: You may notice an odor when dryer is first heated. This odor is common when heating element is first used. The odor will go away.

DOOR REVERSAL (OPTIONAL)

The following instructions are for models with round and square-shaped doors.

Tools needed:

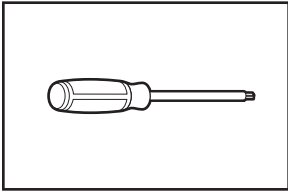

Min. 8" (203 mm) long
TORX, T20, and T25†
screwdrivers

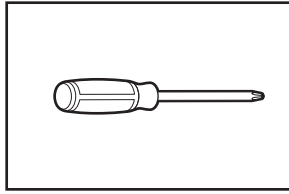

#2 Phillips screwdriver

REVERSE DOOR SWING: ROUND-SHAPED DOOR

DOORS WITH ELECTRICAL WIRING:

⚠ WARNING



Electrical Shock Hazard
Disconnect power before servicing.
Failure to do so can result in death or electrical shock.

1. Disconnect wiring from door

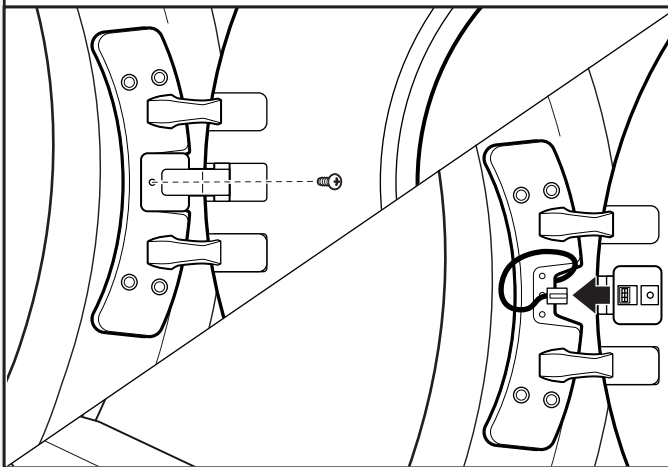

Using a Phillips screwdriver, remove middle screw in hinge. Disconnect wiring. Tuck wiring into opening.

ALL DOORS:

2. Remove door from dryer

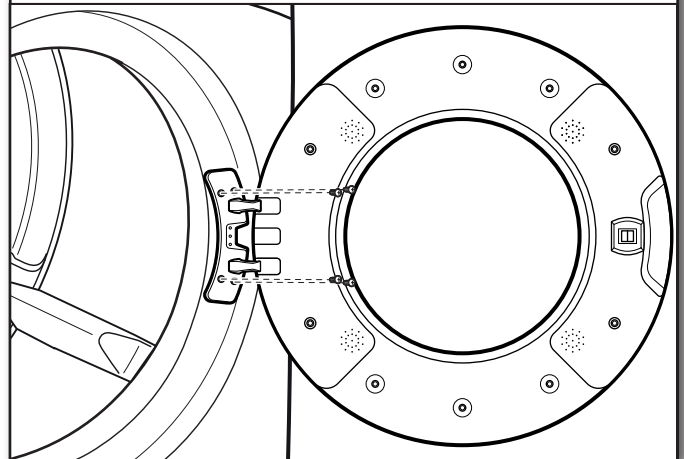

IMPORTANT: If the protective film has not yet been removed from the dryer, peel the film from the dryer door before proceeding. Using a T25 screwdriver, remove the four screws securing the door hinge to the dryer and lift the door up and out to remove. Place the door on a soft towel or other non-scratch surface.

3. Move the door strike

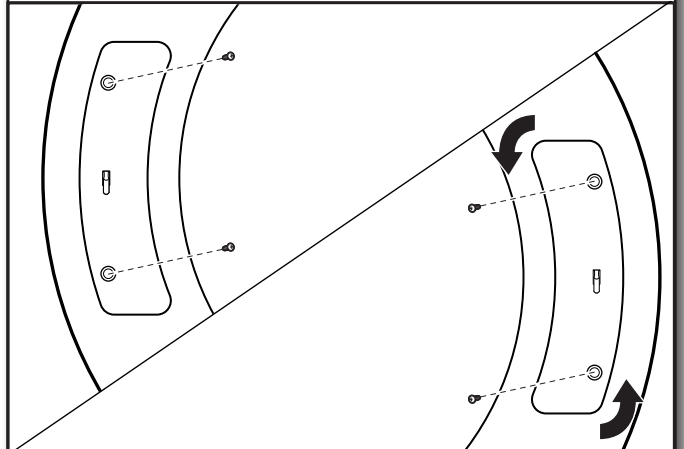

Using a T25 screwdriver, remove the two screws securing the door strike to the door frame of the dryer. Rotate the strike 180° and attach to the opposite side of dryer door frame with the two screws removed earlier, as shown.

†TORX, T20, and T25 are trademarks of Acument Intellectual Properties, LLC.

4. Remove inner door from outer door

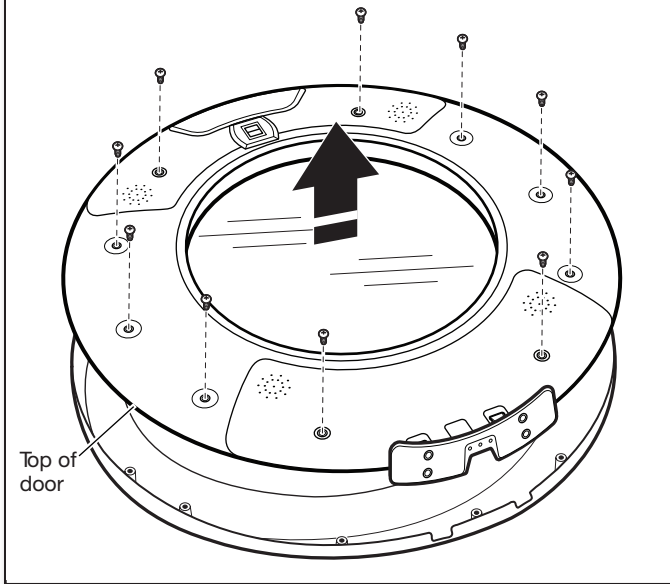

Position the door with the inside of the door facing up. Using a Phillips screwdriver, remove the 10 screws securing the inner door to the outer door.

5. Remove hinge

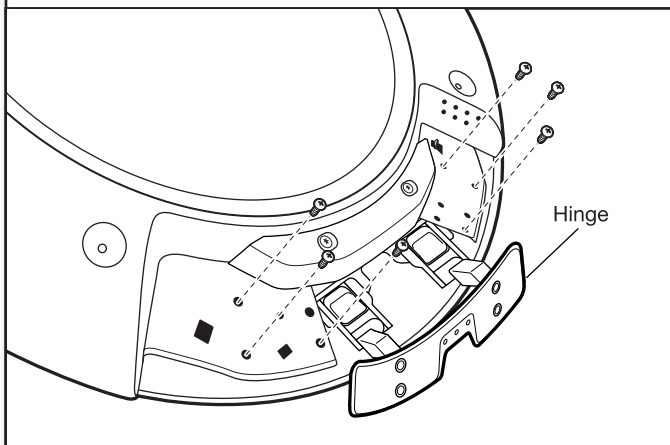

Using a T20 screwdriver, remove the six screws holding the hinge assembly in place.

6. Remove latch

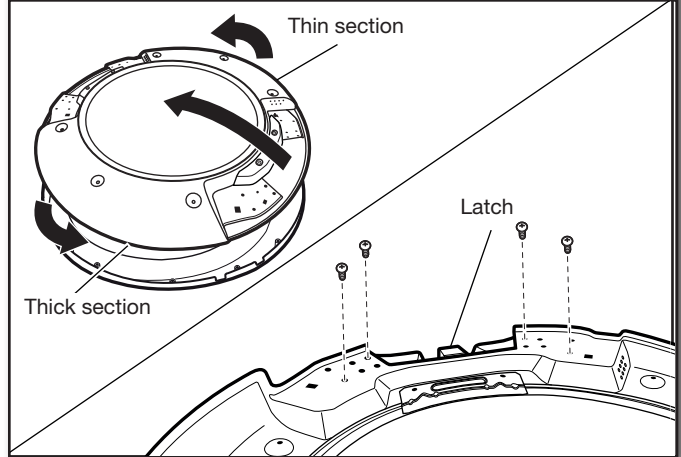

Flip and rotate the inner door 180° so that the thin section is at the top and the thick section is at the bottom. Using a T25 screwdriver, remove the four screws securing the latch plate in place.

7. Reinstall latch on opposite side

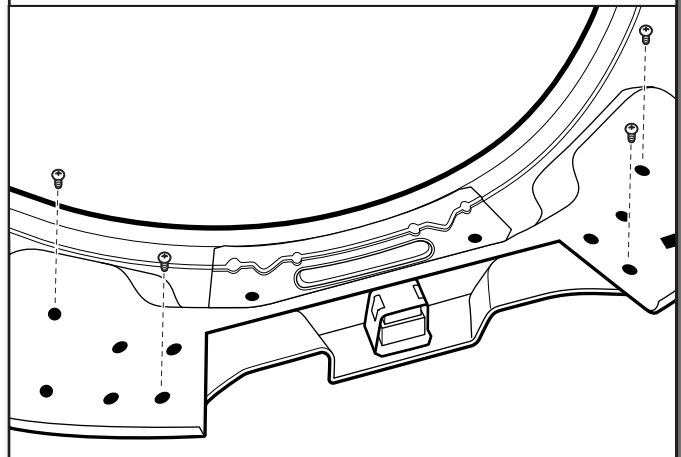

Using a T25 screwdriver, reinstall the latch plate on the opposite side from which it was removed with the four screws removed earlier.

8. Reinstall hinge assembly on opposite side

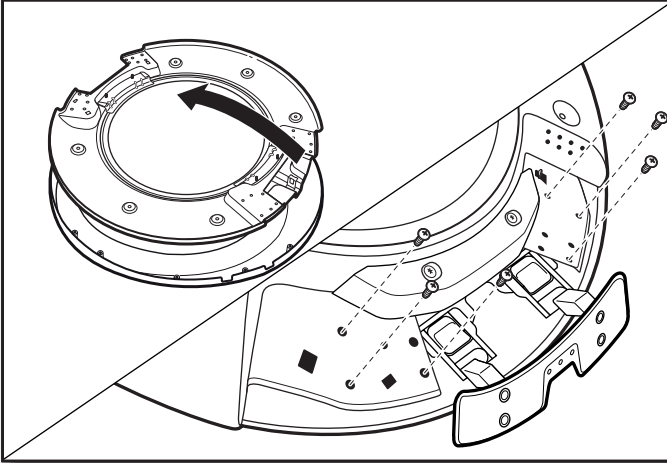

Flip over the inner door to the left. Using a T20 screwdriver, reinstall the hinge assembly on the opposite side from which it was removed.

10. Reposition rotating assembly and tubing

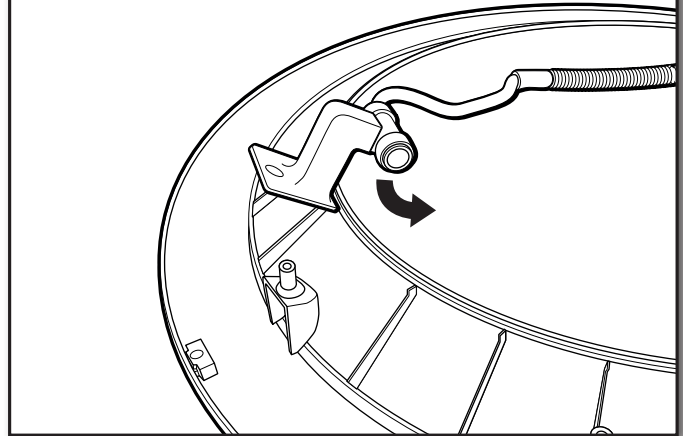

Reposition rotating assembly and tubing 180° to opposite side of the door.

DOORS WITH ELECTRICAL WIRING:

9. Remove rotating assembly

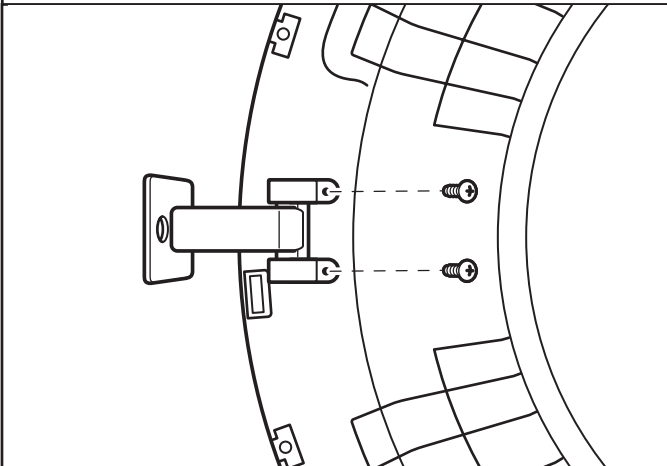

Lift off inner door assembly. Using a Phillips screwdriver, remove the two screws securing the rotating assembly to the door.

11. Rotate assembly bottom and fasten in place

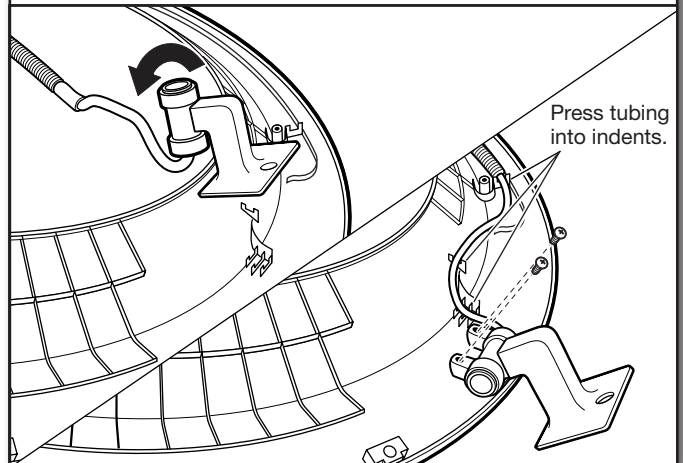

Rotate bottom of assembly 180° towards you and secure assembly with the two screws removed earlier, using a Phillips screwdriver. Press tubing into indents.

IMPORTANT: Make sure to swing hinge down in front of rotating assembly (see Step 12).

ALL DOORS:

12. Reinstall inner door assembly

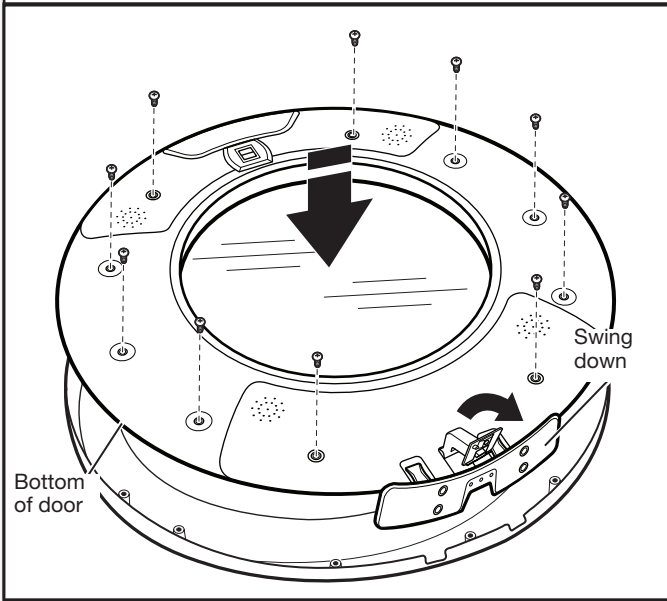

Position the door with the inside of the door facing up. Using a Phillips screwdriver, reinstall the 10 screws removed earlier, securing the inner door to the outer door.

DOORS WITH ELECTRICAL WIRING:

14. Reconnect wiring

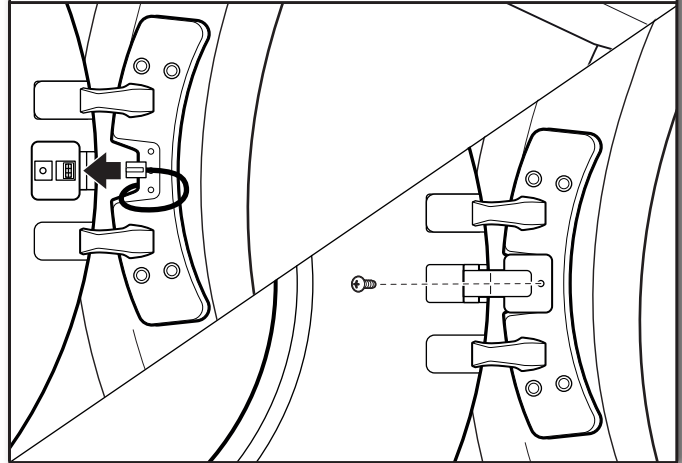

Plug in wire. Using a Phillips screwdriver, secure the rotating assembly to the hinge with the screw removed earlier.

13. Reinstall door on dryer

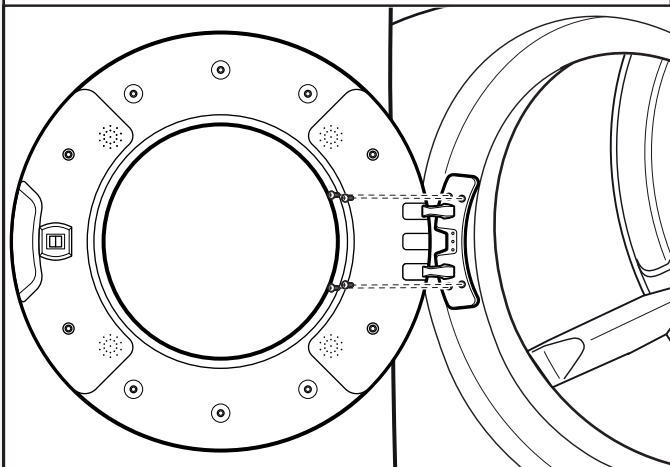

Doors with electrical wiring: Pull the wire through the front panel opening before reinstalling the door.

Insert the tabs on the hinge into the mounting slot and slide down to engage the top tab. Secure in place with the four T25 screws removed earlier.

REVERSE DOOR SWING: SQUARE-SHAPED DOOR

1. Remove door from dryer

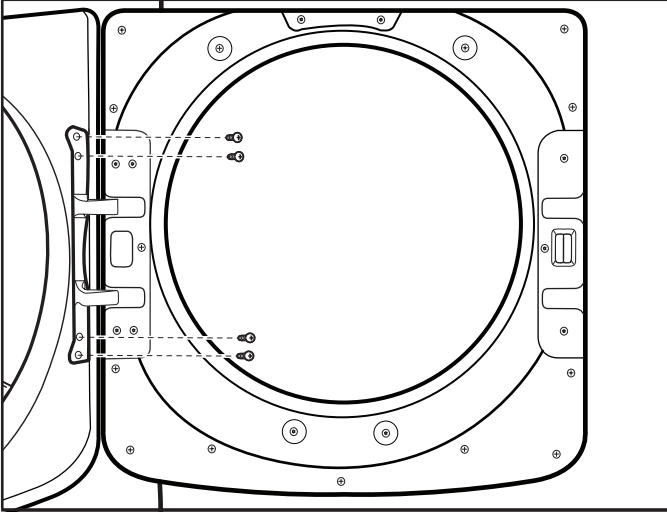

Using a T25 screwdriver, remove the four screws securing the door hinge to the dryer and lift up and out to remove the door. Place the door on a soft towel or other non-scratch surface. Retain or set aside the four screws.

2. Move the door strike

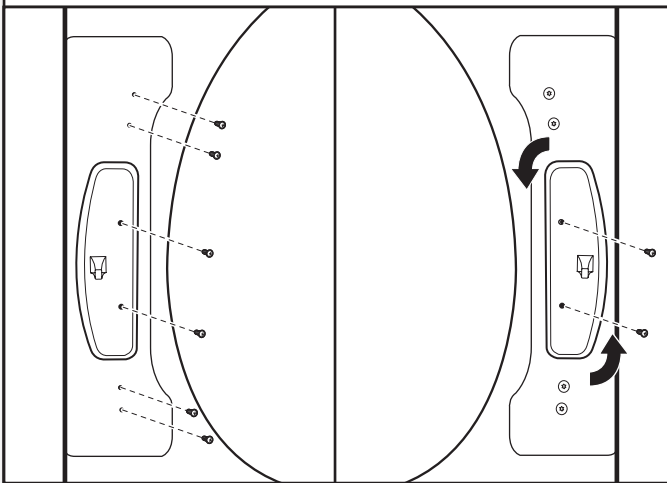

Using a T25 screwdriver, remove the two screws securing the door strike to the door frame of the dryer. Remove the four screws above and below the door strike and set aside for later use. Rotate the strike 180° and attach to the opposite side of dryer door frame, as shown.

3. Remove inner door from outer door

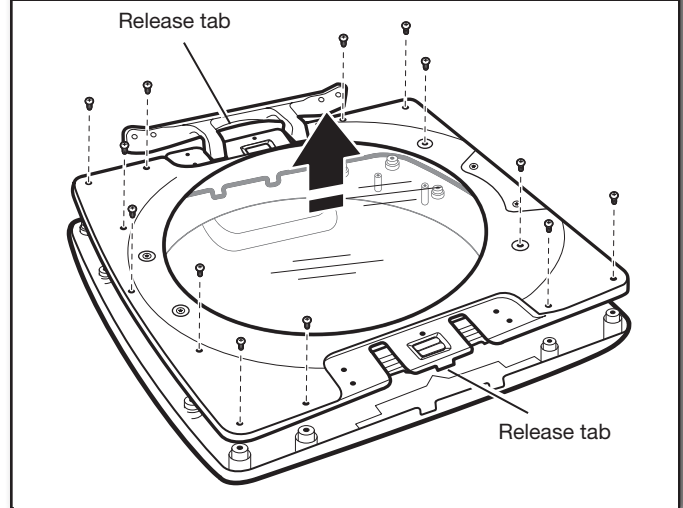

Position the door with the inside of the door facing up. Using a Phillips screwdriver, remove the 13 screws securing the inner door to the outer door. Lift off the inner door and set aside.

NOTE: There is a small release tab on each side of the door. If the inner and outer door do not separate easily, slide a credit card, putty knife, or similar flat object between the inner and outer doors at the locations shown to release the tab.

4. Remove hinge and latch from inner door

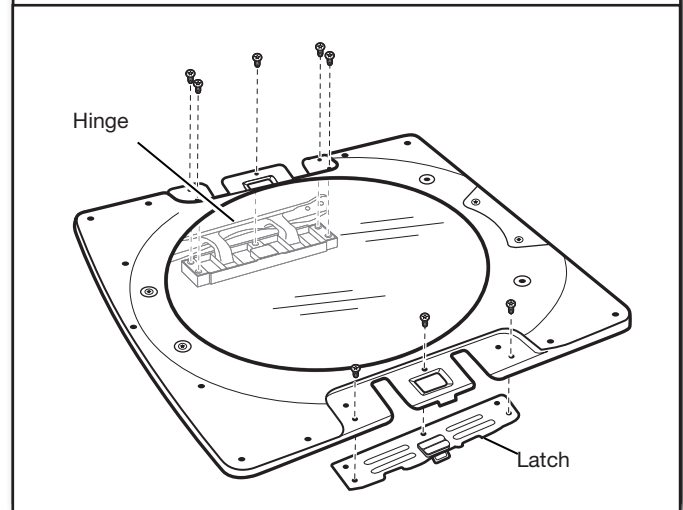

Using a T25 screwdriver, remove the three screws securing the latch plate and the five screws holding the hinge assembly in place.

5. Reinstall hinge and latch on opposite sides

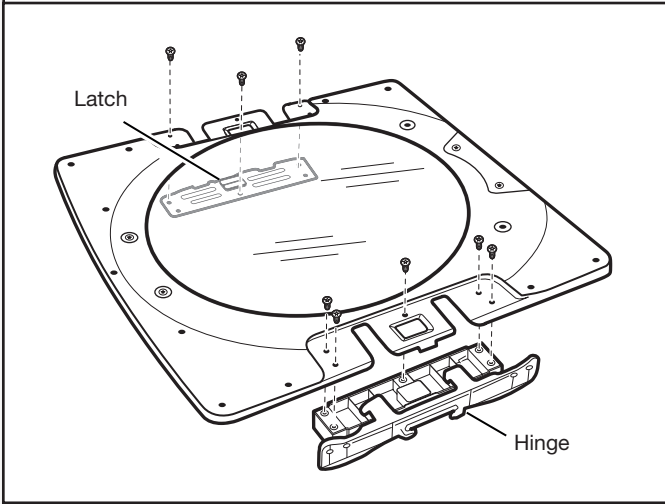

Using a T25 screwdriver, reinstall the latch plate and hinge assembly on the opposite sides from which they were removed.

7. Reattach door to dryer

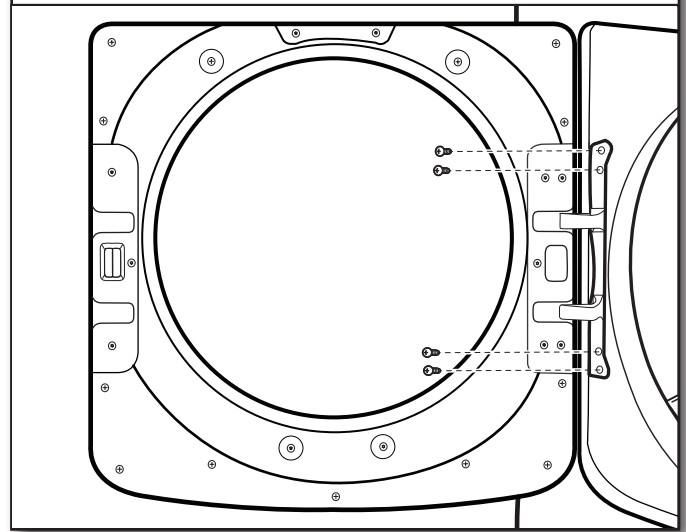

Using a T25 screwdriver, reinstall the four screws securing the door hinge to the dryer.

6. Reattach inner door to outer door

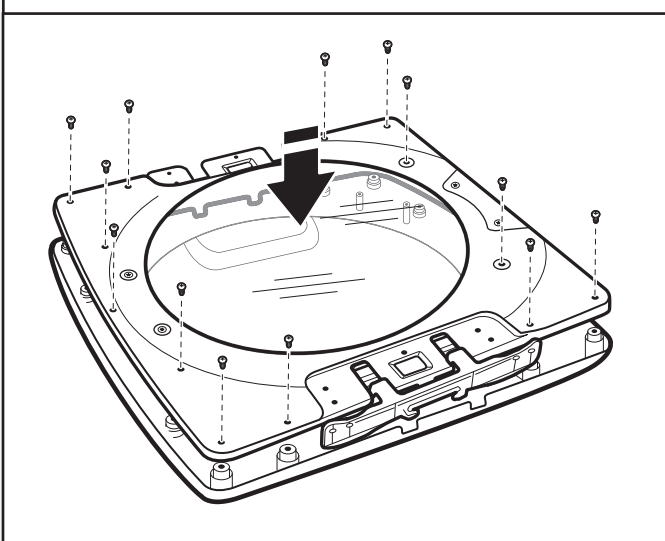

Position the inner door on the outer door assembly. Using a Phillips screwdriver, secure with the 13 screws removed earlier.

乾衣機安全

您與他人的安全都非常重要。

本公司已在這份手冊與電器上提供許多重要的安全提示訊息，請務必一一閱讀並遵守。



這是安全警示符號。

此符號表示存在可能導致您或他人傷亡的潛在危險。

所有安全提示訊息前都有安全警示符號以及「危險」或「警告」字樣。分別代表：



若不立即遵照指示，將導致您死亡或重傷。



若不遵照指示，將導致您死亡或重傷。

所有安全提示訊息都會告訴您有哪些潛在危險、如何降低受傷機率，以及不遵守指示會有哪些後果。



警告——「火災風險」

乾衣機安裝必須由符合資質的安裝人員進行。

安裝乾衣機必須遵守製造商說明與當地法規。

不得安裝塑料排氣管或軟金屬（箔型）導管。如果安裝了軟金屬導管，必須是家電製造廠家指定的類型，符合乾衣機使用要求。軟排氣管容易塌陷、受擠壓和積聚絨毛。這些情況會阻礙乾衣機氣流，增加火災風險。

為降低重傷或死亡風險，必須遵守安裝說明。

請妥善保存上述安全說明



火災危險

若未確切遵循安全維護警告可能導致嚴重的人身受傷、死亡或資產毀損。

不得在排氣管內安裝增壓風機。

按乾衣機製造商的安裝說明，安裝所有乾衣機。



警告：

火災或爆炸危險

若未確切遵循安全維護警告可能導致嚴重的人身受傷、死亡或資產毀損。

- 不得在此區域或任何其他電器區儲存或使用汽油或其他可燃蒸氣和液體。

- 聞到瓦斯味的處理方法：

- 不得嘗試啟用任何電器。
- 不得觸碰任何電氣開關、不得使用大樓內任何電話。
- 撤離室內、大樓或區域內的所有住戶。
- 立即借用鄰居電話，致電您的瓦斯公司。遵循瓦斯公司的指示說明。
- 若您無法聯絡瓦斯公司，致電消防局。

- 必須由合格安裝人員、服務代理商或瓦斯公司進行安裝和維修。

警告： 瓦斯洩漏不見得往往可透過氣味偵測得到。
瓦斯公司建議您使用 UL 或 CSA 核准的瓦斯偵測器。
欲知更多資訊，請聯絡您的瓦斯公司。
若偵測到瓦斯洩漏，遵循「聞到瓦斯味的處理方法」之指示說明。

重要事項： 瓦斯安裝必須符合本地法規。若本地未制訂法規，則應遵循國家燃氣法規 ANSI Z223.1/NFPA 54 (National Fuel Gas Code, ANSI Z223.1/NFPA 54)，或天然氣和丙烷氣安裝法規 CSA B149.1 (Natural Gas and Propane Installation Code, CSA B149.1)。

乾衣機必須按本地法規進行電氣接地。若本地未制訂法規，則應遵循國家電氣法 ANSI/NFPA 70 (National Electrical Code, ANSI/NFPA 704)，或加拿大電氣法規第 1 部份 CSA C22.1 (Canadian Electrical Code, Part 1, CSA C22.1)。

重要安全說明

丟棄或儲存舊的乾衣機時，請把門拆下。

請妥善保存上述安全說明

安裝要求 工具與零件

在開始安裝之前，請準備好所需的工具與零件。

所有安裝所需工具：

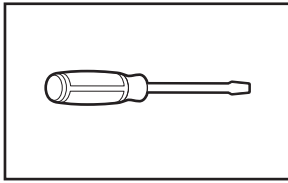

一字起子

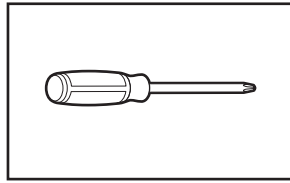

#2 十字起子

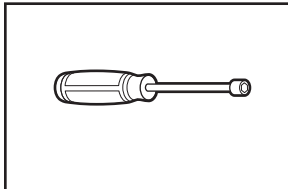

1/4" 和 5/16" 套筒起子
(建議)

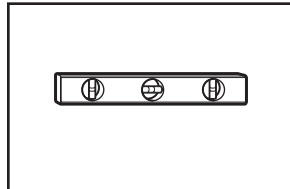

水平儀

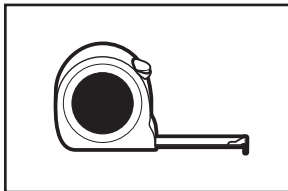

捲尺

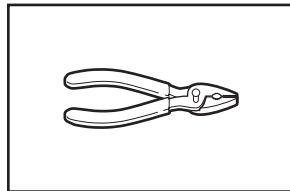

鉗子

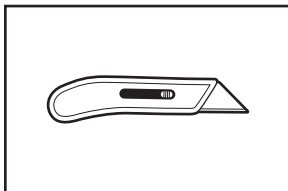

實用刀

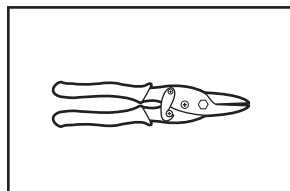

錫剪 (新排氣管安裝)

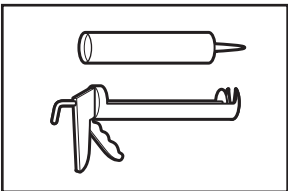

填縫槍和填縫料 (安裝新排氣管)

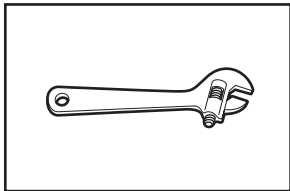

活動扳手，開口為 1" 或六角頭套筒扳手

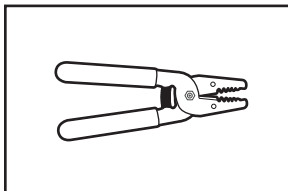

剝線鉗 (單線安裝)

瓦斯安裝所需工具：

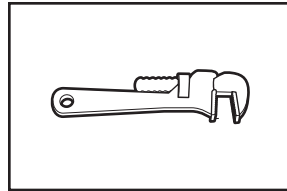

8" 或 10" 管鉗

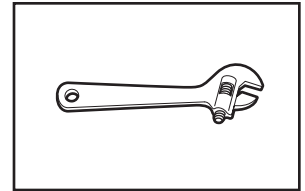

8" 或 10" 活動扳手 (連接瓦斯)

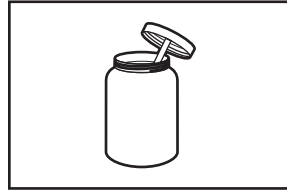

用以抗丙烷氣的管線接縫填料

隨附零件 (所有機種)

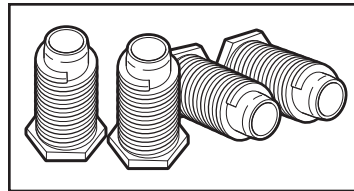

水平支腳 (4)

需要的零件 (蒸氣機種)：

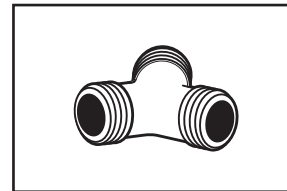

Y 型連接器

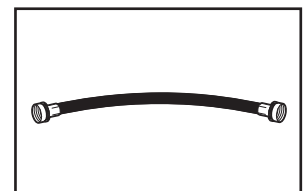

2' 進水管

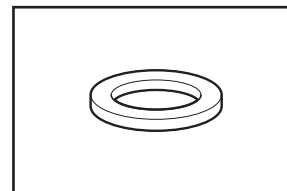

橡膠墊圈



5' 進水管

零件套件位於乾衣機滾筒內。檢查零件是否齊全。

備註：若安裝底座或使用堆疊套件，請勿使用水平支腳。

需要的零件 (乾衣機未隨附)：

- 排氣管管夾
- 排氣管彎管和彎管器

也許您的安裝需要更多零件。請檢查您所在地的法規。檢查現有的電源供應和排氣系統。購買零件前請閱讀「電氣要求」和「排氣要求」。

若使用電源線：

使用標示為乾衣機專用的 UL 認證電源線組件。組件應內含：

- UL 認證 30 A 電源線，額定值最低 120/240 V。應為類別 SRD 或 SRDT 電線，且至少 4 ft. (1.22 m) 長。連接乾衣機的電線末端須為帶向上翻轉尾端的環形或扁平接頭。

- UL 認證固定頭。

其他設備選擇（乾衣機未隨附）：

欲知更多乾衣機適用的配件，請參閱「使用保養指南」。

地點要求

檢查法規要求。某些法規會限制或不允許把乾衣機安裝在車庫、櫥櫃、移動房屋或臥室區域。請聯絡您的本地建築巡視員。

 **警告**



爆炸危險

保持易燃易爆物料與蒸汽——例如汽油——遠離乾衣機。
如果把乾衣機安裝在車庫內，務必確保其離地至少18英寸（460mm）。
否則可能導致人員死亡、爆炸或起火。

您需要：

- 可允許適當排氣管安裝的地點。請參看「排氣要求」章節。
- 瓦斯型乾衣機額外需要 15 或 20 A 電路，電子乾衣機則為 30 A 電路。
- 若使用電源線，需要在乾衣機任一邊的 2 ft. (610 mm) 內設置接地電插座。請參閱「電氣要求」。
- 地板必須能承載重達 200 lbs 的乾衣機。(90.7 kg)。也請考慮配套設備的重量。
- 冷水水龍頭須位於注水閥的 4 ft. (1.2 m) 範圍內，且水壓須達 20–120 psi (138–827 kPa)。可購買「需要的零件」所註明的必要零件，以使用洗衣機的水源。
- 平整地面，整台乾衣機下的坡度最多 1" (25 mm)。若坡度大於 1" (25 mm)，安裝「延長乾衣機支腳組件」，零件編號 279810。若乾衣機不平整，也許無法妥善滾動衣物，且自動傳感器行程也許無法正在運行。
- 若安裝在車庫，把乾衣機放在離地面最少 18" (460 mm) 高之處。若使用底座，需選用高度為 18" (460 mm) 之底座。
- 乾衣機不得安裝或存放於曝露於水或天氣因素之下的地方。

重要事項：不得將乾衣機曝露於水源、天氣或溫度低於 40°F (4°C) 的環境下操作、安裝或儲存乾衣機。低溫可能導致乾衣機於「自動感應乾衣行程」結束時不會關機，而延長乾衣時間。

乾衣機規格 正視圖：

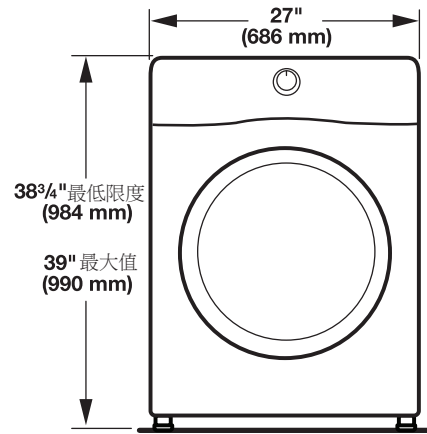

側視圖：

Whirlpool 機種

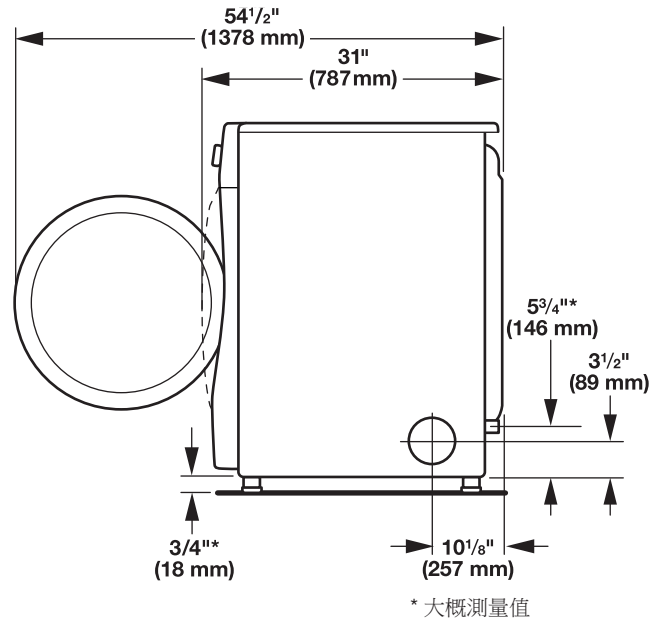

Maytag 機種

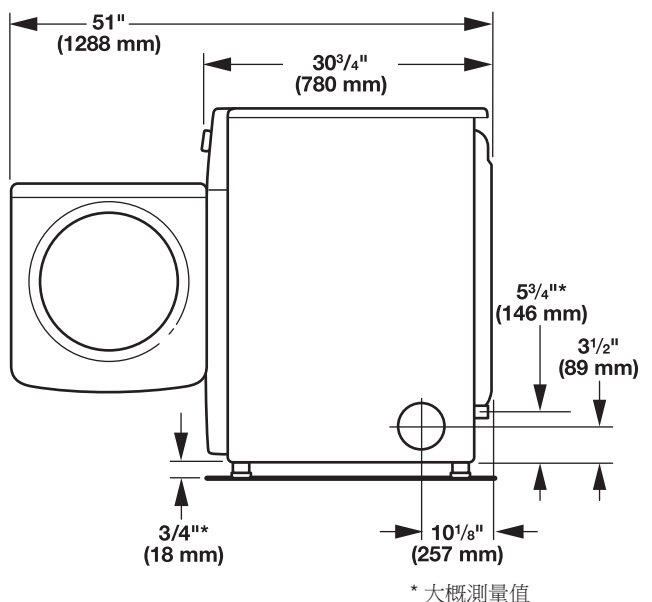

背面視圖：

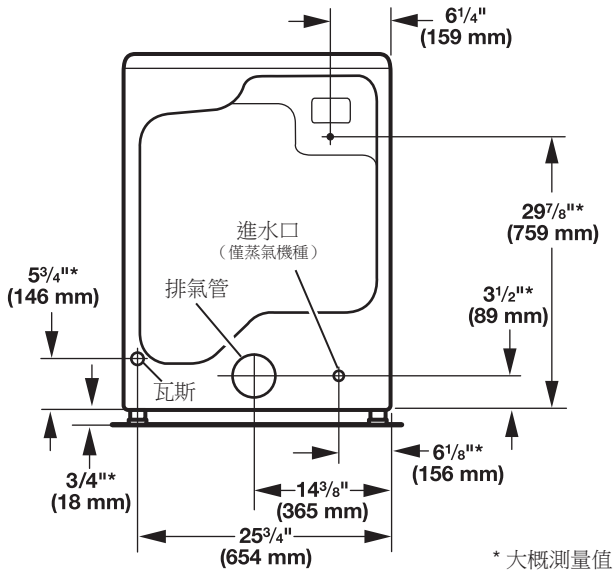

備註：多數安裝要求在乾衣機後預留至少 5" (127 mm) 的空隙，以安裝帶彎管接頭的排氣管。請參看「排氣要求」章節。

安裝空間

針對每種安排，考慮預留較多空間，以便能輕鬆進行安裝和維修、放置配對電器、以及保持和牆壁、門和地板角條的距離。空間須足以把門完全打開。在乾衣機四周增加空間，以減少噪音傳播。若以安裝櫥櫃門或百葉門，門的上下必須要有空氣開口。

檢查法規要求。某些法規會限制或不允許把乾衣機安裝在車庫、櫥櫃、移動房屋或臥室區域。請聯絡您的本地建築巡視員。

備註：不得在安裝乾衣機的櫥櫃內安裝其他燃料電器。

嵌入式或壁櫥式安裝的安裝空間

顯示建議規格，以及最低允許空間。

- 為安裝與維修方便，應預留額外空間。
- 也許須為牆壁、門、地板角條、乾衣機排氣和瓦斯管預留更多空間。
- 應考慮在乾衣機四周預留空間，以減少噪音傳播。
- 如乾衣機安裝在帶門的櫥櫃內，門的上方與下方必須開有最小的通風口。可以接受帶有同樣通風口的百葉門。
- 也需要考慮配對電器的空間。

建議安裝空間（僅乾衣機）：

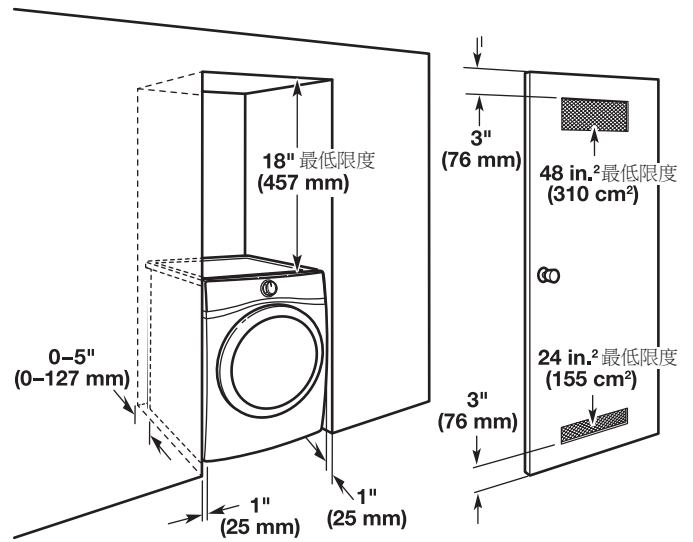

僅直背式排氣管後方可預留 0" (0 mm)。若僅為蒸氣機種，進水管不得扭曲。

自訂櫥櫃下安裝：

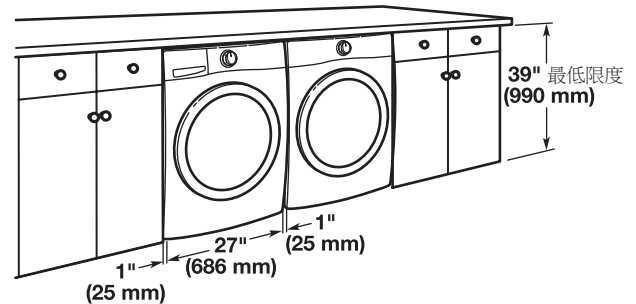

電氣要求

您有責任：

- 聯絡合格電工。
- 於獨立的 30 A 電路上提供必要的 3 或 4 線、單相、120/240 V、60 Hz、純交流電電源供應（或若在序號/標示牌上註明，則為 3 或 4 線、120/208 V 電源供應），電線兩邊接入保險絲。連接至獨立的分支電路。不要在中性或接地電路上接入保險絲。
- 請勿使用延長線。
- 若法規許可且已用獨立接地電線，建議您請合格電工決定適當接地路徑。

電氣連接

欲妥善安裝乾衣機，您必須決定將使用的電氣連接類型，並遵循此處提供的相關指示說明。

- 這台乾衣機出廠時，就已經可以採用 4 線式電源供應接線法。如要正常安裝 4 線式電源供應接線方式，您必須用綠色的接地螺絲，將 4 線式電源線的綠色接地線固定到乾衣機機體上。如果乾衣機本身已經採用 3 線式電源供應接線方式，就必須用綠色接地螺絲在乾衣機機體上另外接地。

若使用電源線：

使用標示為乾衣機專用的 UL 認證電源線組件。組件應內含：

- UL 認證 30 A 電源線，額定值最低 120/240 V。應為類別 SRD 或 SRDT 電線，且至少 4 ft. (1.22 m) 長。連接乾衣機的電線末端須為帶向上翻轉尾端的環形或扁平接頭。
- UL 認證固定頭。

若您使用這樣的插座：



4 線插座 (14-30R)

選擇帶有環形或扁平接頭的 4 線式電源線和 UL 認證固定頭。4 線電源線至少需 4 ft. (1.22 m) 長，且需有四條 10 號銅線，並搭配 NEMA 類別 14-30R 的 4 孔型插座。接地線（接地導線必須是綠色或裸色）。中性導線必需以白色外表作辨識。



3 線插座 (10-30R)

選擇帶有環形或扁平接頭的 3 線式電源線和 UL 認證固定頭。3 線電源線至少需 4 ft. (1.22 m) 長，且需有三條 10 號銅線，並搭配 NEMA 類別 10-30R 的 3 孔型插座。
注意：除了 3 線式電源線外，還必須使用外部接地導線，並且連接到外部接地接頭（綠色螺絲）。

若以直接連接：

電纜線必須符合電源供應（4 線或 3 線），而且還需要：

- 撓性被覆電纜或非金屬被覆銅電纜（附接地線），並以撓性金屬導管覆蓋。所有載流導線都必須絕緣。
- 10 號實心銅線 或 5.5 mm² 絞線（不得使用鋁線）至少需有 5 ft. (1.52 m) 長。

接地說明

- 接地型電源線的乾衣機：
這台乾衣機必須接地。如果故障或失靈，接地能提供電流阻力最小的途徑，降低觸電風險。本乾衣機配備內有設備接地導線的纜線以及接地插頭。插頭必須插入以正確方式安裝與接地的插座（並需符合當地標準和規定）。
- 永久連接的乾衣機：
本乾衣機必須連接至接地金屬、永久線路系統，或將乾衣機的設備接地端或引線連接至設備之接地端。

警告： 設備接地導線連接不當時可能導致觸電。若不確定乾衣機是否正常接地，可請合格電工或維修代表或技師代為檢查。請勿變造乾衣機附上的插頭：如果無法插入插座，請由合格電工安裝適當插座。

請妥善保存上述安全說明

電乾衣機的電源連接

電氣要求

 **警告**



觸電危險

將插頭插入一個 4 孔的接地電源插座上。
否則可能導致人員傷亡或觸電。

您有責任：

- 聯絡合格電工。
- 於獨立的 30 A 電路上提供必要的 4 線、單相、120/240 V、60 Hz、純交流電電源供應、電線兩邊接入保險絲。建議安裝延時保險絲或斷路器。連接至獨立的分支電路。

欲知更多資訊，請參閱「使用保養指南」的「協助或維修」所刊載的維修編號。

接地說明

- 接地型電源線的烘乾機：
這台乾衣機必須接地。如果故障，接地能提供電流阻力最小的途徑，降低觸電風險。本乾衣機配備內有設備接地導線的纜線以及接地插頭，插頭必須插入以正確方式安裝與接地的插座（並需符合當地標準和規定）。

警告：設備接地導線連接不當時可能導致觸電。若不確定乾衣機是否正常接地，可請合格電工或維修代表或技師代為檢查。請勿變造乾衣機附上的插頭；如果無法插入插座，請由合格電工安裝適當插座。

請妥善保存上述安全說明

瓦斯型乾衣機電源連接

電氣要求

 **警告**



觸電危險

將插頭插入一個三孔接地電源插座上。
請勿拔掉接地插腳。
請勿使用轉接頭。
請勿使用延長線。
否則可能導致人員傷亡、失火或觸電。

- 要求 120 V、60 Hz、純交流電、15 或 20 A 帶保險絲的電源。建議安裝延時保險絲或斷路器。也建議安裝僅為本乾衣機供電的獨立迴路。

接地說明

- 接地型電源線的烘乾機：
這台乾衣機必須接地。如果故障，接地能提供電流阻力最小的途徑，降低觸電風險。本乾衣機配備內有設備接地導線的纜線以及接地插頭，插頭必須插入以正確方式安裝與接地的插座（並需符合當地標準和規定）。

警告：設備接地導線連接不當時可能導致觸電。若不確定乾衣機是否正常接地，可請合格電工或維修代表或技師代為檢查。請勿變造乾衣機附上的插頭；如果無法插入插座，請由合格電工安裝適當插座。

請妥善保存上述安全說明

瓦斯供應要求

**警告**

爆炸危險

使用經 **CNS** 認證 核准的新瓦斯管線。
安裝止氣閥。
穩妥拴緊所有瓦斯接頭。
若連接至丙烷氣，請合格人員確定氣壓不超過 **13" (33 cm)** 水柱。
合格人員的例子包括：
認證供暖人員、
授權瓦斯公司人員，以及授權服務人員。
否則可能導致人員死亡、爆炸或起火。

瓦斯類型

天然氣：

本乾衣機的配備旨在使用天然氣。機器經 **UL** 認證，經過轉換後可搭配使用丙烷氣。

- 乾衣機必須按您家中使用的瓦斯類型，配備正確的燃燒器。燃燒器資訊可參考乾衣機門上的標示牌。如它不適用於家中使用的瓦斯類型，聯絡您的經銷商，或參照「使用保養指南」的「協助或維修」所刊載的電話號碼。

丙烷氣轉換：

重要事項：必須由合格技工進行轉換。

未洽詢您的瓦斯公司前，不得嘗試將家電的型號/序號標示牌上註明的瓦斯改為不同的瓦斯類型。

瓦斯管線

選項 1 (建議方法)

撓性不鏽鋼瓦斯連接器：

- 若本地法規允許，使用全新的撓性不鏽鋼瓦斯連接器（設計經美國瓦斯協會 (**American Gas Association**) 或 **CSA International** 認證），連接您的乾衣機至堅硬瓦斯管線。視需要在不鏽鋼瓦斯連接器和乾衣機瓦斯管之間使用彎管和 **3/8"** 喇叭頭 x **3/8"** NPT 螺牙接管，以預防扭結。

選項 2 (替代方法)

經核准的鋁或銅管：

- 在瓦斯和乾衣機連接的上方，必須安裝 **1/8"** NPT 最少堵塞分支接頭，方便測試測定計。請參閱下方圖解說明。
- 建議使用 **1/2"** IPS 管。
- 若本地法規和瓦斯供應商許可，接受使用 **20 ft. (6.1 m)** 以下的 **3/8"** 核准鋁管或銅管。
- 若使用天然氣，不得使用銅管。
- 超過 **20 ft. (6.1 m)** 應使用較大型管子，以及不同尺寸的螺牙接管。
若您的乾衣機已換用丙烷氣，可使用 **3/8"** 丙烷可相容銅管。
若供應線的總長度超過 **20 ft. (6.1 m)**，使用較大管線。
備註：必須使用抗丙烷氣作用的管線接縫填料。不得使用鐵氟龍 (**TEFLON**)[†] 膠帶
- 必須內含止氣閥。

美國：

必須按國家燃氣法規 **ANSI Z223.1 (National Fuel Gas Code, ANSI Z223.1)**，在乾衣機的 **(6) ft. (1.8 m)** 範圍內安裝獨立的手動止氣閥。必須安裝在方便開關的地方。

加拿大：

必須按 **B149.1 天然氣和丙烷氣安裝法規 (B149.1, Natural Gas and Propane Installation Code)**，安裝獨立的手動止氣閥。建議在乾衣機的 **(6) ft. (1.8 m)** 範圍內安裝獨立的手動止氣閥。必須安裝在方便開關的地方。

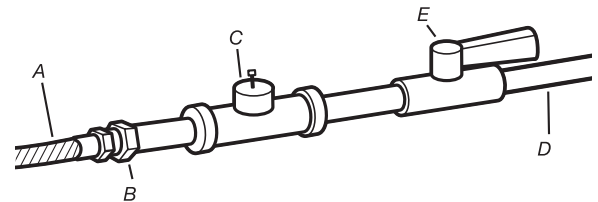

- A. **3/8"** 撓性瓦斯連接器
- B. **3/8"** 連接至喇叭頭螺牙接管的管線
- C. **1/8"** NPT 最少堵塞分支接頭
- D. **1/2"** NPT 瓦斯管線
- E. 瓦斯止氣閥。

[†]TEFLON 是 Chemours 的註冊商標。

瓦斯供應連接要求

- 視需要在撓性瓦斯連接器和乾衣機瓦斯管之間使用彎管和 3/8" 喇叭頭 x 3/8" NPT 螺牙接管，以避免扭結。
- 只可使用管線接縫填料。不得使用鐵氟龍膠帶。
- 本乾衣機必須使用符合 ANSI Z21.24 或 CSA 6.10 瓦斯設備連接器標準的撓性瓦斯連接器，連接至瓦斯管。

燃燒器輸入要求

海拔高度在 2,000 ft. (610 m) 以上：

- 如需安裝在海拔高度 2,000 ft. (610 m) 以上，針對每 1,000 ft. (305 m) 的高度升高，就必須減少 4% 型號/序號標牌中顯示的燃燒器 Btu 測定值。

瓦斯供應壓力測試

- 若壓力高於 1/2 psi，必須中斷乾衣機和瓦斯管的連接。

乾衣機瓦斯管

- 從乾衣機後方伸出的瓦斯管是一個 3/8" 外牙螺紋。

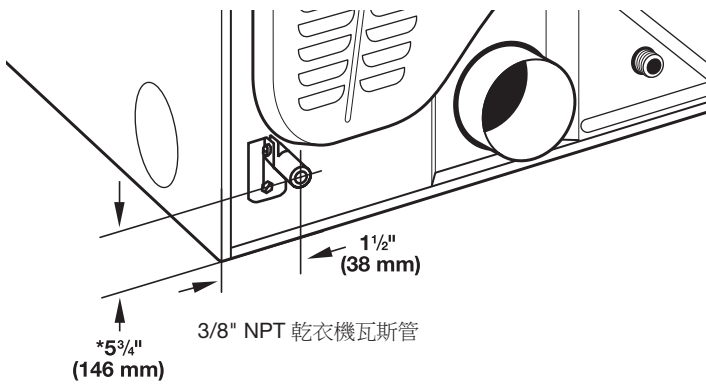

*備註：視底座的型號而定，若乾衣機是架在底座上，必須額外從地面增加 10" (254 mm) 或 15.5" (394 mm) 的瓦斯管高度。若安裝在車庫，瓦斯管的高度必須從地面額外增加 18" (460 mm)。

安裝水平支腳



警告

過重危險

請動用兩名或多名人員搬運與安裝乾衣機。

否則可能導致人員後背或其他部位受傷。

1. 準備安裝乾衣機的水平支腳

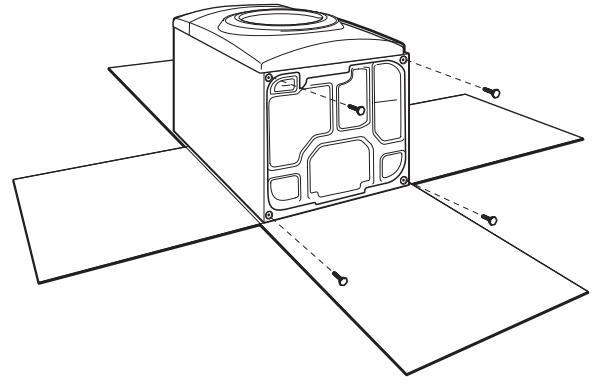

為避免損壞地板，請使用一塊乾衣機包裝盒的大紙板，放在乾衣機的整個背面邊緣。緊緊抓著乾衣機機體（不是控制面板），並輕放在紙板上。

2. 拴上水平支腳的螺絲

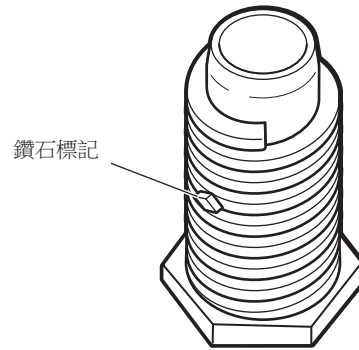

檢查水平支腳並尋找鑽石標記的位置。用手將螺絲腳拴進插孔 - 用扳手拴緊螺絲腳，直到看不見鑽石標記。

把乾衣機包裝的大紙板角落撐柱分別放在乾衣機背面的兩個角落。把乾衣機放直。滑動放在角落撐柱上的乾衣機，直到它接近最後擺放的位置。預留足夠的空間，連接排氣管。

電氣連接

電氣連接

電源線：

警告



火災危險

使用全新 **UL 認證 30 amp** 電源線。

使用 **UL 認證** 固定接頭。

電氣連接前切斷電源。

將中性線（白色或中央電線）接至中央接頭（銀色）。

接地線（綠色或裸色）必須連接至綠色接地端。

連接其餘 **2** 條電源線至其餘兩個接頭（金色）。

穩妥拴緊所有電氣連接。

否則可能導致人員死亡、觸電或火災。

若為直接電線安裝：

警告



火災危險

使用 **10 號** 銅線。

使用 **UL 認證** 固定接頭。

電氣連接前切斷電源。

將中性線（白色或中央電線）接至中央接頭（銀色）。

接地線（綠色或裸色）必須連接至綠色接地導線。

連接其餘 **2** 條電源線至其餘兩個接頭（金色）。

穩妥拴緊所有電氣連接。

否則能導致人員死亡、觸電或火災。

開始作業前：中斷電源連接。

1. 選擇電氣連接類型



4 線式電源線插座（NEMA 類型 14-30R）
請參閱「電源線連接」。



3 線式電源線插座（NEMA 類型 10-30R）
請參閱「電源線連接」。



4 線直接連接：
請參閱「電源線直接連接」。



3 線直接連接：
請參閱「電源線直接連接」。

注意：如果當地法規禁止將機體接地導線連接到水線，請參閱「3 線式外部接地法」。這種接地方式必須搭配電源線或直接接線。

2. 取下接線座蓋板

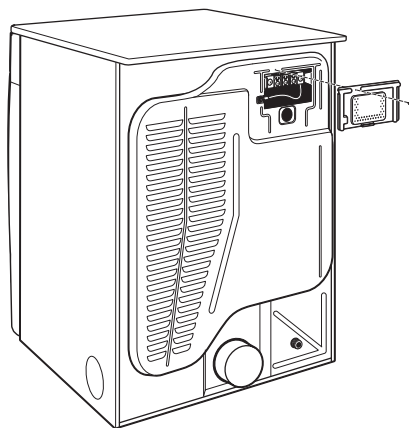

取下固定螺絲和接線座蓋板。

電源線連接

電源線固定接頭

1. 接入電源線固定接頭

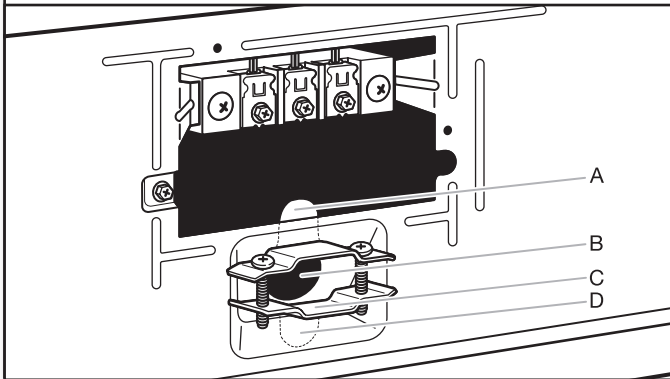

從 3/4" (19 mm) UL 認證固定接頭中取下螺絲。把兩個夾具 (C) 部份的螺栓放在插頭排開口 (B)，當中一個固定耳指向上方 (A)，另一個指向下方 (D)，並放置就定位。拴緊固定接頭螺絲，把兩個夾具 (C) 接合。

2. 接入電源線至固定接頭

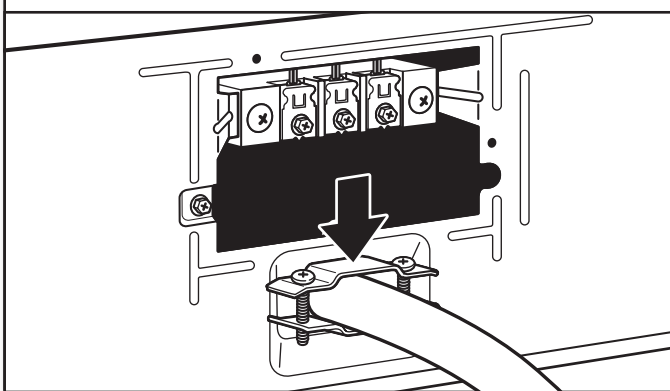

把電源線放進固定接頭。確定電源線的電線絕緣是放在固定接頭內。固定接頭應僅僅接合乾衣機外殼，並以水平位置擺放。此時不要再進一步拴進固定接頭螺絲。

若您使用這樣的插座：



4 線式電源線插座 (NEMA 類型 14-30R)：
請參閱本頁的「4 線電源線連接」。



3 線式電源線插座 (NEMA 類型 10-30R)：
請參閱第 13 頁的「3 線電源線連接」。

4 線式電源線連接

重要事項：移動房屋要求 4 線連接，且在本地法規不許可的地區，請使用 3 線連接。

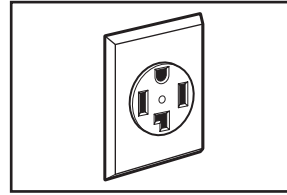

4 線插座 (NEMA 類型 14-30R)

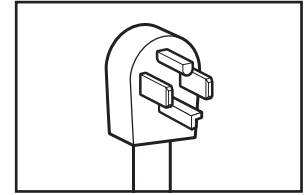

4 腳插頭

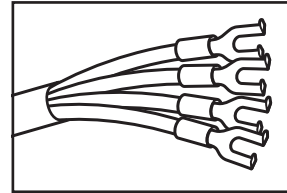

帶向上翻轉尾端的扁平接頭

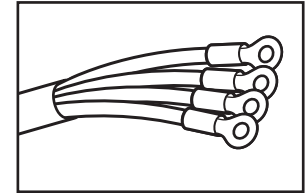

環形接頭

1. 連接接地線

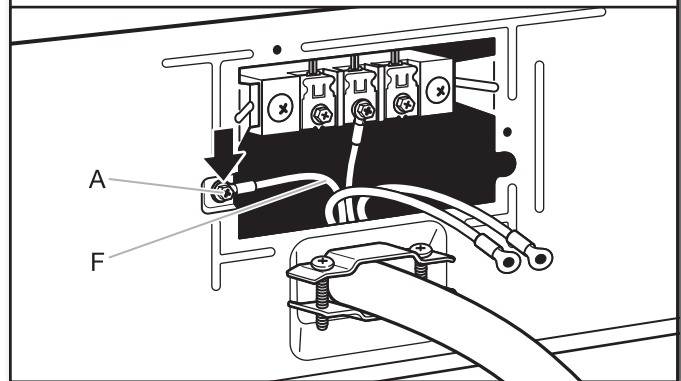

連接位於綠色外部接地導線螺絲下方的電源線接地線 (F) (綠色或裸色)。拴緊螺絲。

2. 連接其餘電線

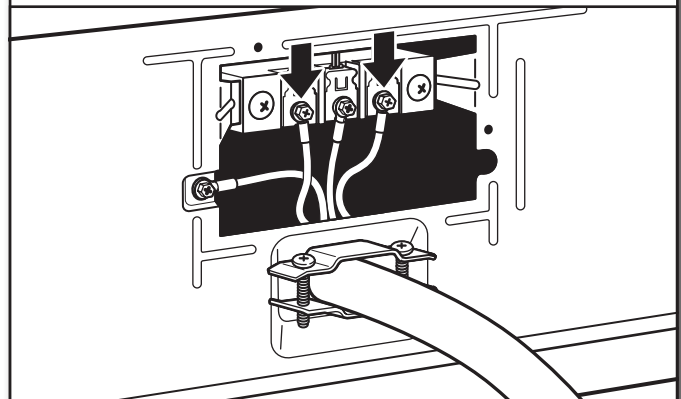

將其餘之電源線接裝於接線座接線端子固定螺絲下。拴緊螺絲。最後，重新將接線作蓋板之固定耳插入乾衣機背板之插槽內。再以固定螺絲將蓋板固定妥。現在請參閱「排氣要求」。

連接電源線 - 直接連接

纜線固定頭

1. 安裝纜線固定頭

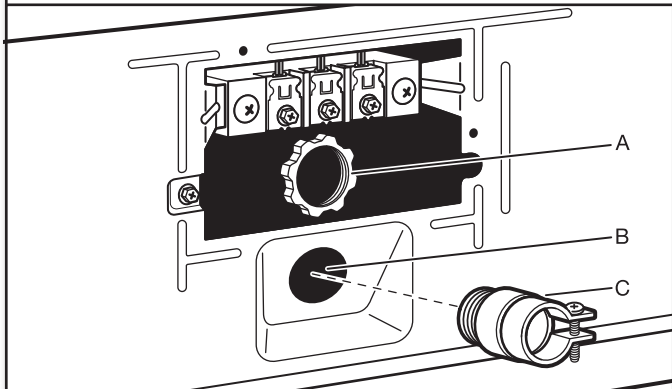

從 3/4" (19 mm) UL 認證固定頭中取下可拆卸導管連接器 (A) 和任何螺絲。把固定頭中螺紋部份穿過接線座下方的開口 (B) 的下方。伸手進去接線座開口，拴上可拆卸導管連接器 (A) 的螺絲至固定頭的螺紋，然後拴緊它。

2. 固定頭

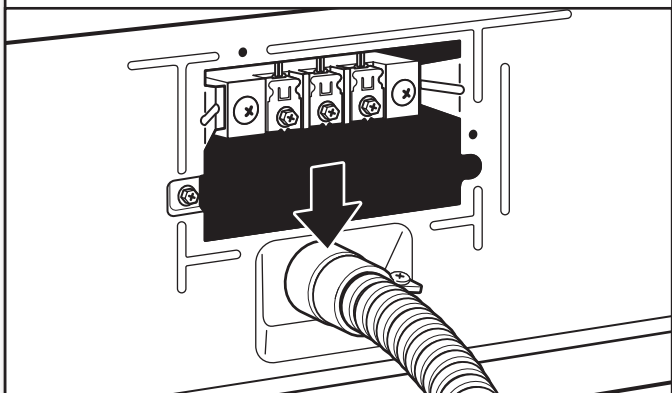

把直接電源纜線放進固定頭。固定頭應緊緊地固定在接乾衣機上，並以水平位置擺放。鎖緊固定頭上之螺絲，使其夾緊電纜線。

若您使用這樣的電線：



4 線直接連接：
請參閱本頁的「4 線直接電源線連接」。



3 線直接連接：
請參閱第 15 頁的「3 線直接電源線連接」。

4 線直接電源線連接：

重要事項：移動房屋，以及本地法規不許可使用 3 線連接的地區，請使用 4 線連接。

1. 準備直接連接用的 4 線電線纜線

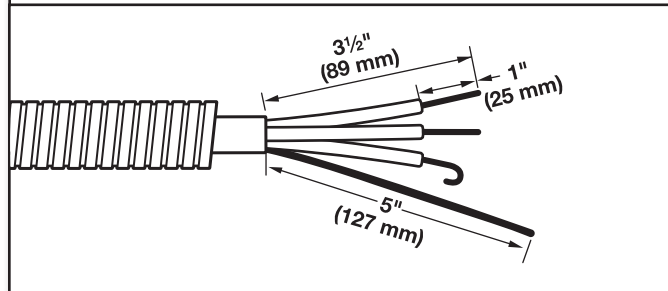

電纜線必需額外有 5 ft. (1.52 m) 長，好讓乾衣機可視需要移動。從纜線末端剝掉外皮 5" (127 mm)，留下 5" (127 mm) 長的裸接地線。從其餘三條線上剪下 1 1/2" (38 mm)。並剝下絕緣層 1" (25 mm)。把電線的末端都彎曲成鉤子狀。

2. 連接中性接地線和中性線

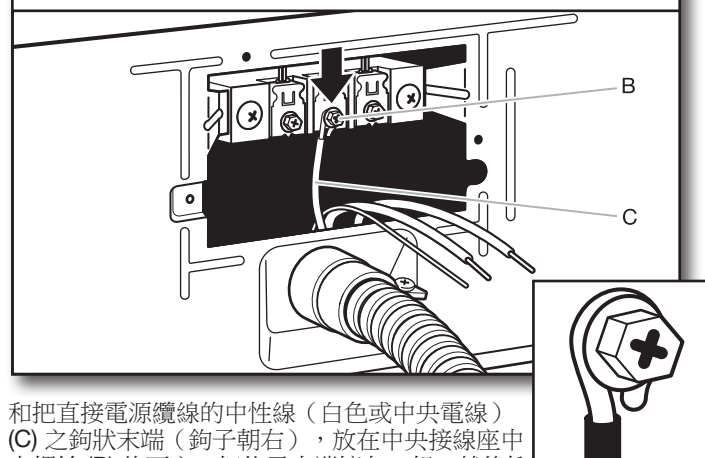

和把直接電源纜線的中性線（白色或中央電線）(C) 之鉤狀末端（鉤子朝右），放在中央接線座中央螺絲 (B) 的下方。把鉤子末端擠在一起，然後拴緊螺絲。

3. 連接接地線

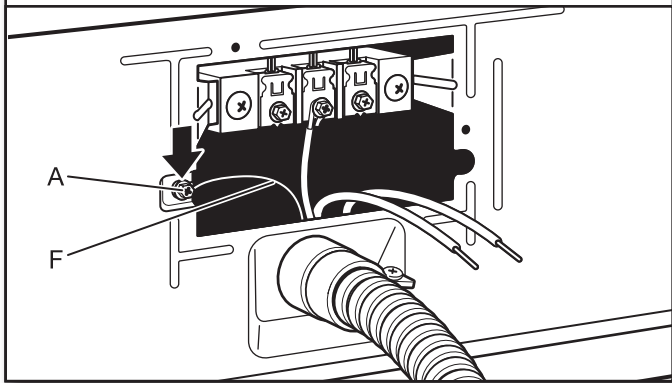

連接電纜線的接地線（綠色或裸線）(F) 至綠色外部接地導線螺絲 (A) 的下方。拴緊螺絲。

2. 連接中線中性線

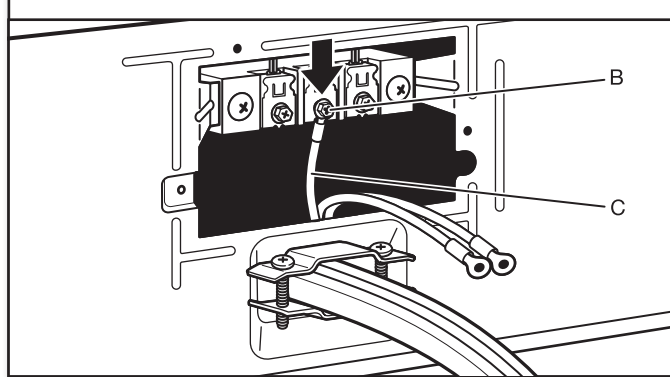

連接中和電源線或位於中央接線座螺絲 (B) 下方的纜線的中性線（白色或中央電線）(C)。拴緊螺絲。

4. 連接其餘電線

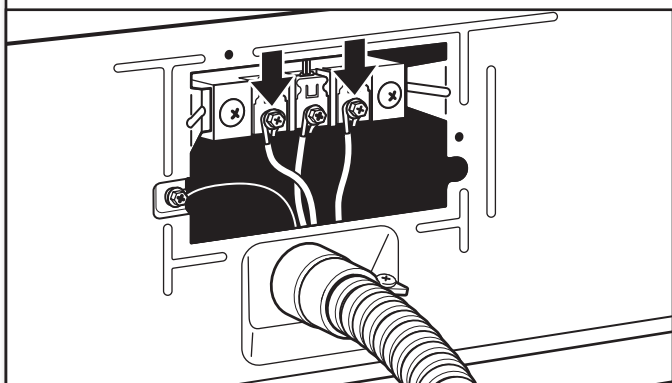

把其餘電纜線的鉤狀末端放在接線座右側螺絲下方之下（鉤子朝右）。把鉤子末端擠在一起，然後拴緊螺絲。最後，裝回接線座蓋板，並以螺絲鎖緊。現在請參閱「排氣要求」。

3. 連接其餘電線

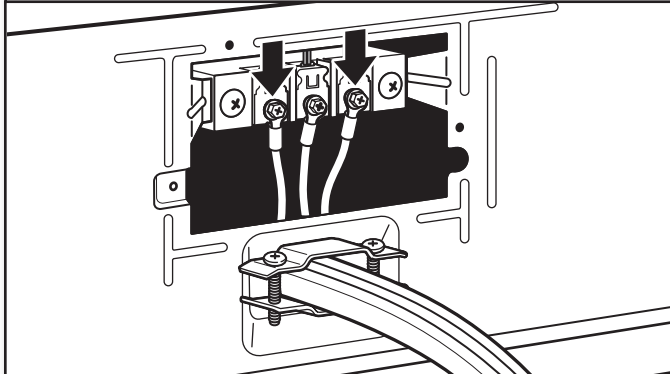

把其餘電線的末端放在接線座外側螺絲的下方。拴緊螺絲。

3 線式外部接地法 (電源線如圖所示)

重要事項：接線前必須向合格電工確認這種接地方式安全無虞。如果需要使用 3 線式接線，就必須根據以下說明連接外部接地線。

1. 準備連接中性接線

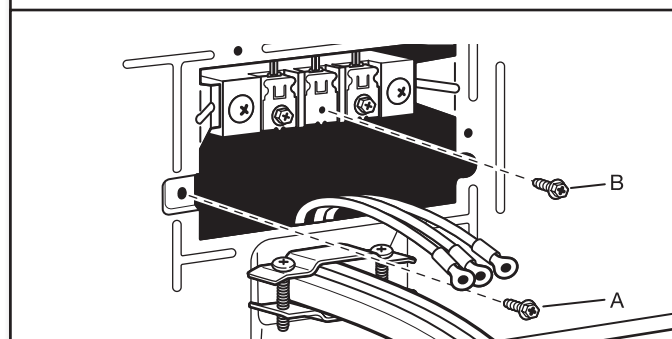

如第 12 或 14 頁所示，為您的電氣連接法安裝正確的固定頭。取下中央接線座螺絲 (B)。綠外部地導線螺絲中取下。

4. 連接外部接地線

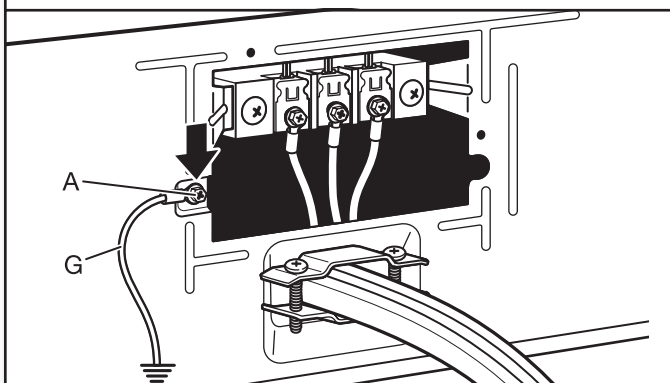

連接綠色外部接地導線螺絲 (A) 下方的獨立銅接地線至適當地接地端。最後，裝回接線座蓋板，並以螺絲鎖緊。現在請參閱「排氣要求」。

進行瓦斯連接 (僅瓦斯型機種)

 **警告**



爆炸危險

使用經 CNS 認證核准的新瓦斯管線。

安裝止氣閥。

穩妥拴緊所有瓦斯接頭。

若連接至丙烷氣，請合格人員確定氣壓不超過 **13" (33 cm)** 水柱。

合格人員的例子包括：

認證供暖人員、

授權瓦斯公司人員，以及授權服務人員。

否則可能導致人員死亡、爆炸或起火。

1. 連接瓦斯至乾衣機

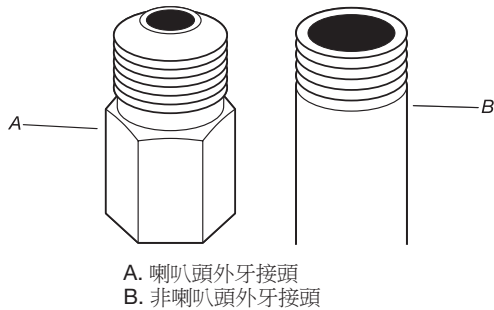

從瓦斯管取下紅色蓋子。用扳手拴緊，連接瓦斯至乾衣機，在所有非喇叭頭外牙接頭上塗上管路接合劑。若使用撓性金屬管，確定沒有扭曲。

備註：若為丙烷氣連接，必須使用抗丙烷氣作用之管線接縫填料。不得使用鐵氟龍膠帶。

2. 規劃管線的接管連接 (選項 1)

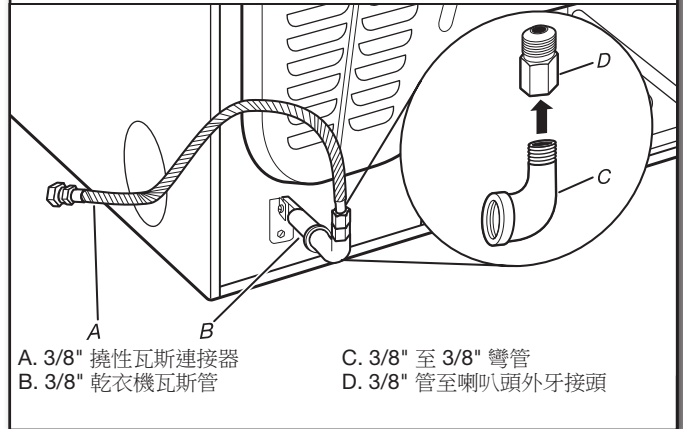

必須合併使用不同的接管，連接乾衣機至現有的瓦斯管。建議連接如上圖所示。您的連接可能按供應管線的類型、大小和地點而有所不同。

3. 開啟止氣閥

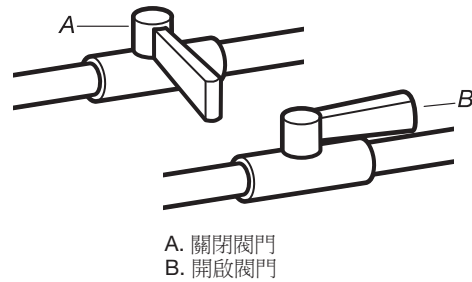

開啟供應管線的止氣閥；若手把和瓦斯管平行，表示已開啟閥門。接著刷上經核准的不腐蝕洩漏偵測劑，測試所有連接。出現泡泡顯示有洩漏。修正任何找到的洩漏

排氣

排氣要求

**警告**



火災危險

使用硬質金屬排氣管(含伸縮鋁管)。
切勿使用塑料排氣管。
切勿使用金屬軟箔排氣管。
否則可能導致人員傷亡或失火。

警告：為降低起火風險，本乾衣機必須排氣至戶外。

重要事項：務必遵守所有政府法規與條例。乾衣機排氣管不得連接任何建築的排氣口、煙囪、牆壁、天花板、閣樓、管線夾層或隱蔽空間。只可使用堅硬或撓性的金屬排氣管作排氣。

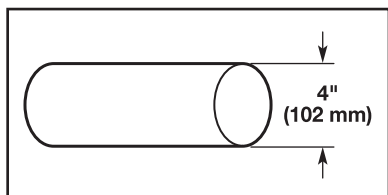

4" (102 mm) 硬質金屬排氣管

- 只可使用 4" (102 mm) 硬質金屬排氣管與管夾。
- 不得使用塑料或金屬箔排氣管。

堅硬金屬排氣管：

- 為確保最佳的乾衣性能，避免壓壞與扭結，建議使用。

軟金屬排氣管：（只可接受可進入清潔的情況）

- 管道必須得到完整的延長和支持，在乾衣機完成安裝後。
- 清除多餘管道，避免下垂與扭結而導致氣流減少及性能不佳。
- 不得安裝在封閉的牆壁、天花板或地板內。
- 總長度不應超過 7¼ 呎（2.4公呎）。
- 如「排氣系統圖」所示，整體排氣系統設計必須考量撓性金屬排氣管的長度。

備註：如果要使用原有之排氣系統，請清除整個系統內的絨毛，確保排氣罩無絨毛堵塞。以堅硬或軟金屬排氣管替代塑料或金屬箔排氣管。重新查閱「排氣系統圖」，如有需要，更改現有的排氣系統，以獲得更好的性能。

排氣罩：

- 排氣罩應蓋住排氣管，預防嚙齒類動物和昆蟲進入家中。
- 必須至少距離地面或任何可能堵塞排氣管的物品（例如花卉、石頭、刷子或雪）12"（305 mm）。
- 不得使用帶有磁性門鎖的排氣罩。

建議型式：

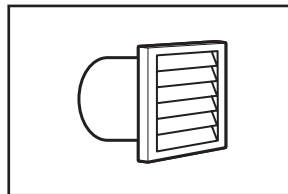

百葉罩

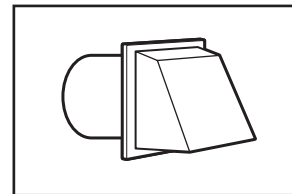

箱型罩

可接受型式：

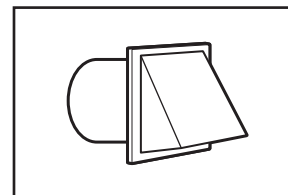

斜角罩

彎頭：

45° 彎管可提供比 90° 彎管更好的氣流。

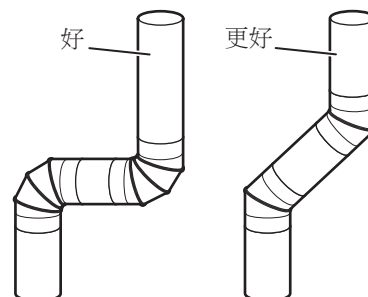

管夾：

- 使用管夾封閉所有接口。
- 排氣管道連接或固定不得使用螺絲或其他會插入管道內部的固定安裝，因為它們會積聚絨毛。不得使用導管膠帶。

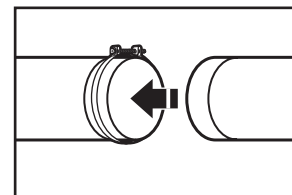
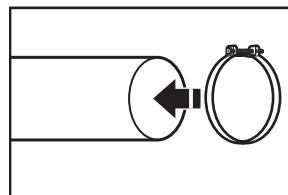

設計排氣系統

建議排氣管安裝：

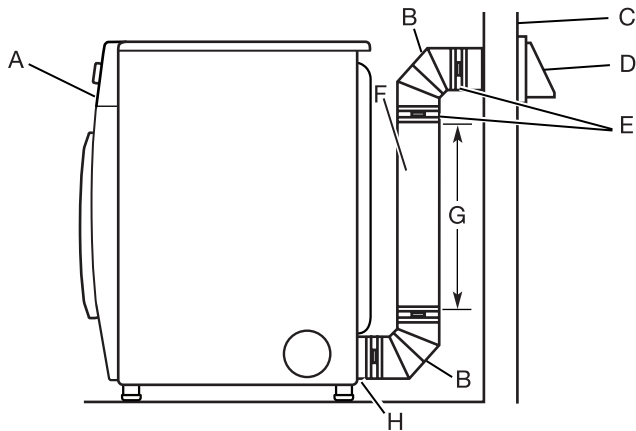

- A. 乾衣機
- B. 彎管
- C. 牆壁
- D. 排氣罩
- E. 管夾
- F. 堅硬金屬或撓性金屬排氣管
- G. 必要長度的排氣管，已連接彎管
- H. 排氣口

確定排氣管路徑：

- 選擇最筆直通向戶外的路徑。
- 使用最少數量的彎管與轉彎設計安裝路徑。
- 在使用彎管或製造轉彎時，應預留盡量多的空間。
- 逐漸折彎管道避免扭結。
- 盡量少用 90° 轉彎。

確定管道長度與所需彎管，以保證最佳乾衣性能。

- 使用下方「排氣系統圖」，確定可以接受的排氣管材料與排氣罩搭配類型。

備註：使用的管道不得長於「排氣系統圖」的規定。如果排氣系統比規定長度更長，則會：

- 縮短乾衣機的使用壽命。
- 降低乾衣機表現，延長乾衣時間，增加能源消耗。

「排氣系統圖」提供的排氣要求有助於達到最佳乾衣表現。

標準排氣系統圖

90° 彎管的數量	排氣管類型	斜角罩
0	堅硬金屬	64 ft. (20 m)
1	堅硬金屬	54 ft. (16.5 m)
2	堅硬金屬	44 ft. (13.4 m)
3	堅硬金屬	35 ft. (10.7 m)
4	堅硬金屬	27 ft. (8.2 m)

警告



火災危險

利用製造商的排氣管組件，蓋住未使用的排氣孔。

聯絡您所在地的經銷商。

否則可能導致人員死亡、觸電、重傷或火災。

選項排氣管安裝：

可把本乾衣機改變為從右邊、左邊或透過底部排氣（除長排氣外的所有機種）。可按意願聯絡本地經銷商，改變乾衣機的排氣出口。

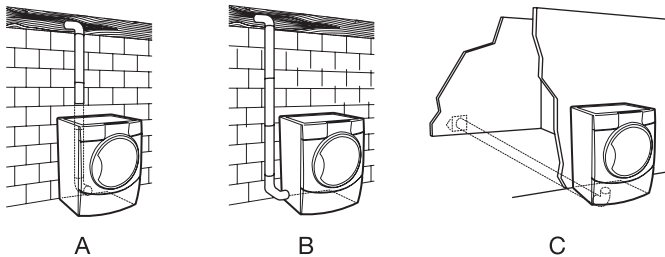

- A. 標準抵消排氣安裝
- B. 左邊或右邊排氣安裝
- C. 底部排氣安裝

長排氣系統圖

90° 彎管的數量	排氣管類型	斜角罩
0	堅硬金屬	160 ft. (48.8 m)
1	堅硬金屬	150 ft. (45.7 m)
2	堅硬金屬	140 ft. (42.7 m)
3	堅硬金屬	130 ft. (39.6 m)
4	堅硬金屬	120 ft. (36.6 m)

欲決定您的機種是否帶有長排氣系統，參考門內序號標牌上標示的類型代碼。範例：電子型號為 DALV - ELE - XXXXXXXX-XXX。

瓦斯型號為 DALV - NAT - XXXXXXXX-XXX。

備註：若為長排氣系統，無論系統有多長，使用盒式罩/百葉罩將增進排氣功能。

2. 連接排氣管與排氣罩

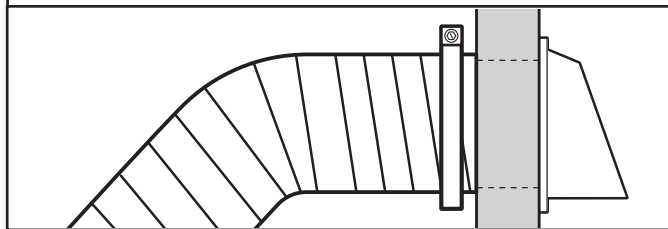

排氣管必須符合排氣罩的尺寸。以4" (102 mm) 管夾把排氣管固定在排氣罩上。儘量使用最直的路徑，放置通往乾衣機位置的排氣管。避免 90° 轉彎。使用管夾封閉所有接口。不得使用導管膠帶、螺絲或其他會插入管道內部的固定安裝，因為它們會積聚絨毛。

安裝排氣系統

1. 安裝排氣罩

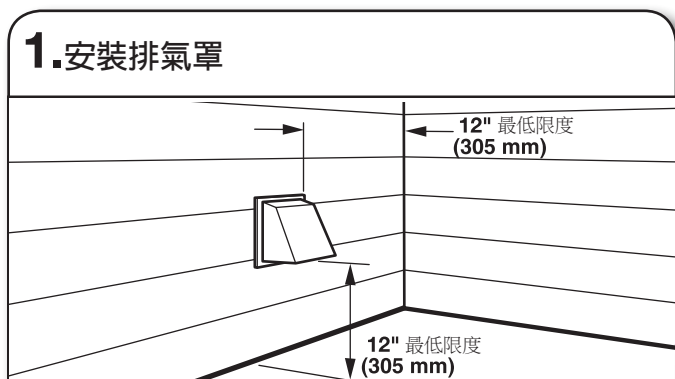

安裝排氣罩，使用填縫劑密封外牆上排氣罩周圍的開口。

連接進水管（僅蒸氣機種）

若為非蒸氣機種，跳閱「連接排氣管」。

必須使用新進水管，連接乾衣機至冷水水龍頭（未隨附）。不得使用老舊管子。

備註：更換已使用 5 年的進水管，以降低水管故障的風險。在管子上記錄管子安裝或更換日期，供日後參考之用。

若發現突起物、扭曲、割痕、磨損或漏水，定期檢查和更換水管。

1. 關閉冷水、取下管子並更換新塑膠墊圈

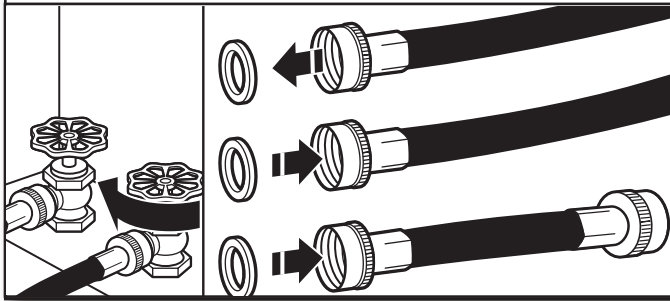

關閉冷水水龍頭並取下洗衣機的進水管。取下進水管的老舊塑膠墊圈，更換新塑膠墊圈。

2. 接入短管和 Y 型連接器

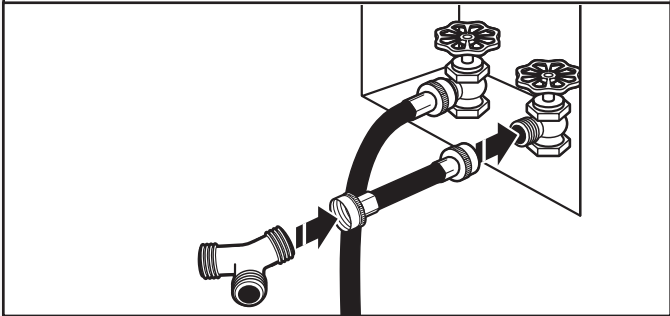

把 2 ft. (0.6 m) 進水管接至冷水水龍頭。用手拴上連接裝置的螺絲，直到它穩妥置於水龍頭上。接著把 Y 型連接器接至 2 ft. (0.6 m) 長進水管的出口端。用手拴上連接裝置的螺絲，直到它穩妥置於連接器上。

3. 拴緊連接裝置

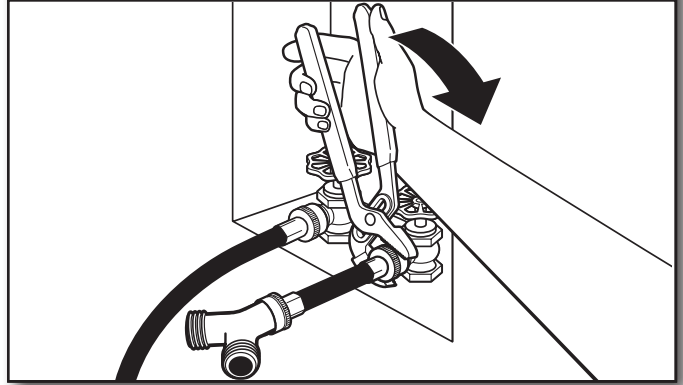

使用鉗子，額外加轉 2/3 圈，拴緊連接裝置。**備註：**不可拴得太緊。此舉可能損壞連接裝置。

4. 接入長管至 Y 型連接器，然後拴緊連接裝置

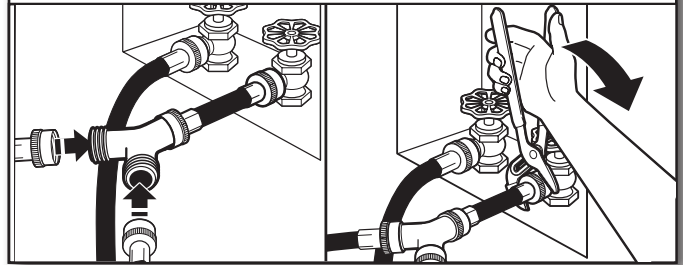

接入其中一條 5 ft. (1.5 m) 進水管末端至 Y 型連接器。接入洗衣機冷水進水管至 Y 型連接器的另外一邊。用手拴上連接裝置的螺絲，直到它穩妥置於連接器上。使用鉗子，額外加轉 2/3 圈，拴緊連接裝置。

備註：不可拴得太緊。此舉可能損壞連接裝置。

5. 接入長管至乾衣機注水閥，然後拴緊連接裝置

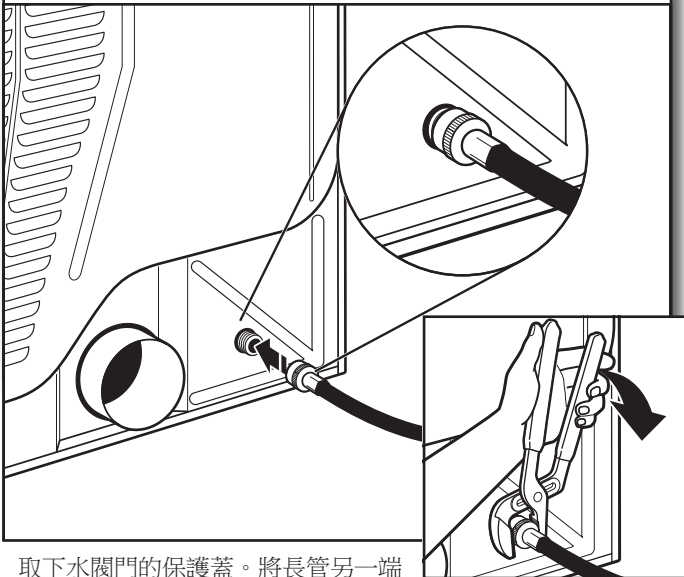

取下水閥門的保護蓋。將長管另一端接至乾衣機背部面板下方的注水閥。用手拴上連接裝置的螺絲，直到它穩妥置於注水閥上。使用鉗子，額外加轉 2/3 圈，拴緊連接裝置。

備註：不可拴得太緊。此舉可能損壞連接裝置。

6. 開啟冷水水龍頭

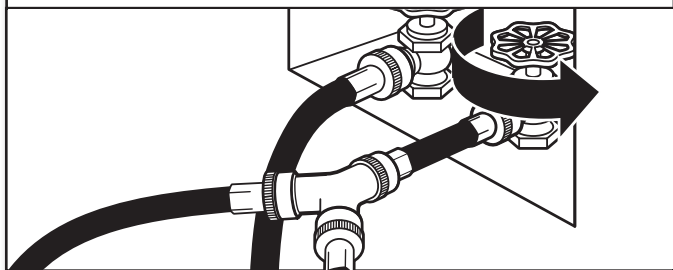

檢查已開啟水龍頭。

7. 檢查洩漏

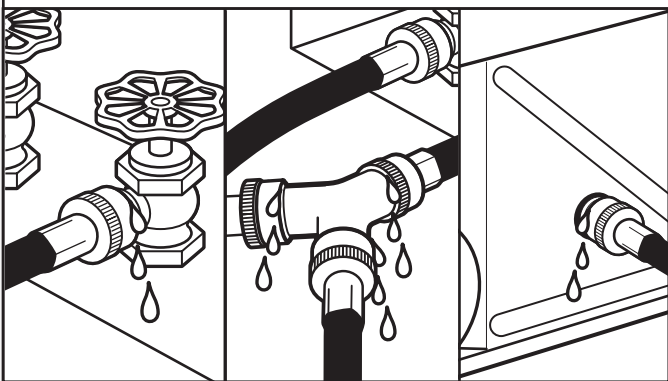

檢查 Y 型連接器、水龍頭和管子的洩漏。

連接排氣管

1. 把排氣管連接到排氣口上

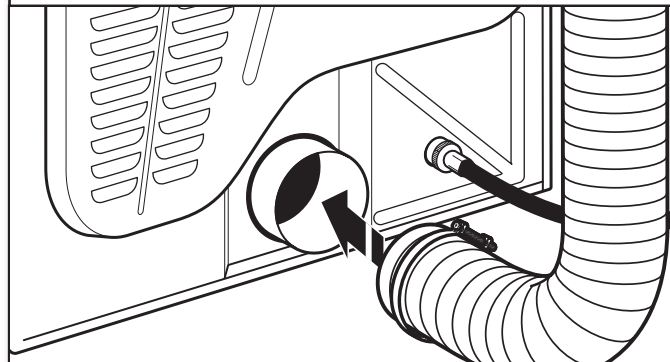

使用 4" (102 mm) 管夾，把排氣管連接到乾衣機的排氣口上。如果連接已有的排氣管，請確保排氣管道乾淨。乾衣機排氣管必須符合乾衣機排氣口與內部的排氣罩尺寸。檢查確保排氣管以利用 4" (102 mm) 管夾固定在排氣罩上。

2. 把乾衣機搬運至最終位置

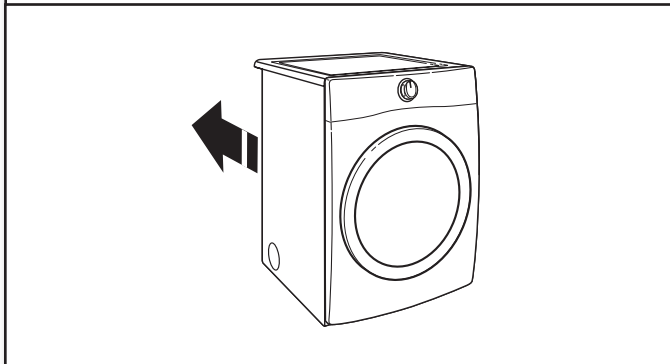

把乾衣機搬運至最終位置，小心不要讓排氣管或撓性瓦斯管碎裂或扭曲。

乾衣機就位後，從乾衣機下方取下角落撐柱和紙板。

放平乾衣機

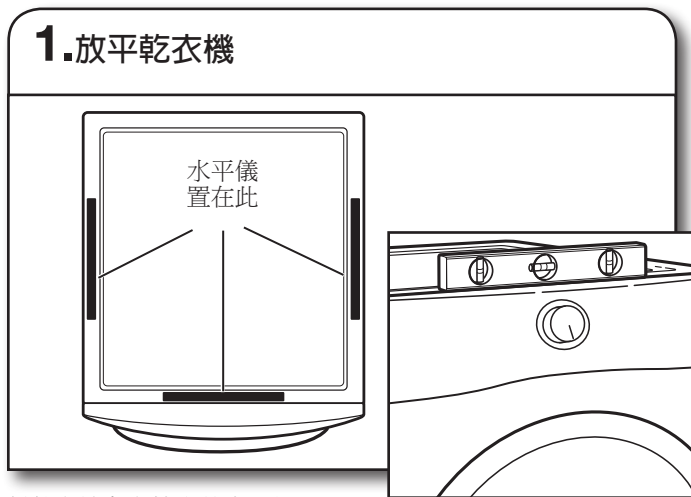

從乾衣機各方檢查其水平位置。
從背面重複檢查至正面。

備註：必須水平放置乾衣機，濕度感應系統才能正確運行。

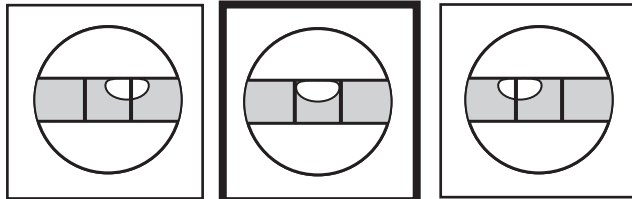

未水平擺放

水平擺放

未水平擺放

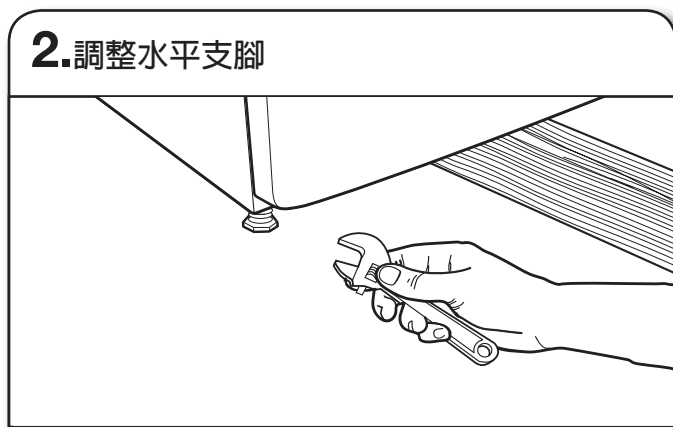

若乾衣機未水平擺放，用木條撐起、用扳手向上或下調整支腳，然後再檢查水平位置一次。一旦已水平擺放乾衣機。確定四個支腳都已穩妥站在地板上，且乾衣機不會搖晃。

完成安裝檢核清單

- 檢查確認清單上的零件已安裝完畢。如果有多餘的零件，請重新檢查所有步驟，看是否有遺漏。
- 檢查確保所有工具齊全。
- 處理/回收所有的包裝材料。
- 確定已開啟水龍頭。
- 檢查 Y 型連接器、水龍頭和管子的洩漏。
- 檢查乾衣機的最終位置。確保排氣管沒有壓壞或扭結。
- 檢查以水平擺放該乾衣機。請參閱「放平乾衣機」。
- 移除乾衣機操作面板上的薄膜及機身殘留的膠帶。
- 以濕布徹底擦拭乾衣機內滾筒，清除灰塵。
- 閱讀「使用保養指南」的「乾衣機使用」。
- 若您住在硬水區，建議使用軟水劑，控制乾衣機內水源系統的水垢累積。一段時間後，石灰垢可能堵塞水源系統的不同部份，進而降低產品效能。大量的水垢累積可能導致更換或維修特定零件。

電力機種：

- 將插頭插入有接地的插座。

瓦斯機種：

- 將插頭插入有接地的插座。
- 檢查已開啟瓦斯供應。
- 檢查洩漏
- 檢查以確定撓性瓦斯管未碎裂或扭曲。

所有機種：

- 選擇「計時烘乾」加熱行程，然後開啟乾衣機。不得選擇「冷風」的設定。
 - 如果乾衣機不啟動，請檢查以下項目：**
 - 控制鍵已設定至運行或「啟動」位置。
 - 已確實按下「啟動」按鍵。
 - 乾衣機的電線已插入插座及/或已連接電源。
 - 保險絲完好，或斷路器未跳開。
 - 乾衣機門已關好。

本乾衣機在第一個行程開始時，自動執行診斷例行檢查。

備註：在乾衣機首次加熱時，可能會散發氣味。加熱元件首次使用時，發出這種氣味是正常的。氣味會漸漸消散。

把門裝至另一邊（選項）

以下說明供圓形和方形門機種專用。

所需工具：

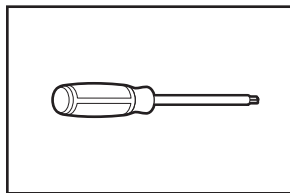

最短 8" 長 TORX、T20、
和 T25+ 螺絲起子

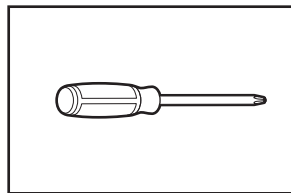

#2 十字起子

把門裝到另一邊圓形門

帶有電子線路的門：

警告



觸電危險

維修前請切斷電源。
否則可能導致人員傷亡或觸電。

1. 斷開門的接線

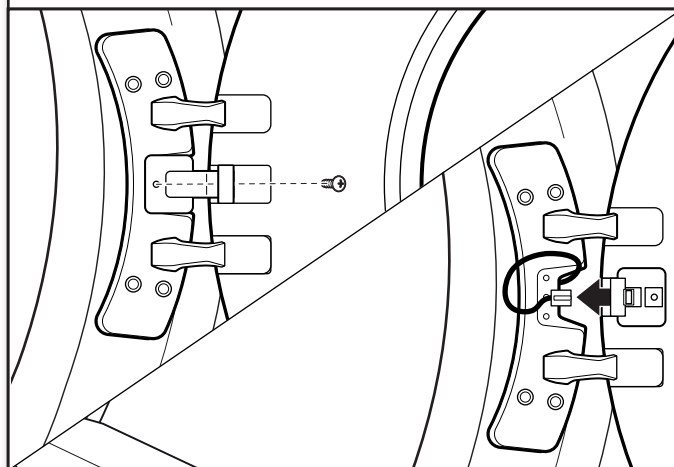

用十字起子取下門鉸鏈中間的螺絲。斷開接線。把電線放進開口處。

所有門：

2. 取下乾衣機門

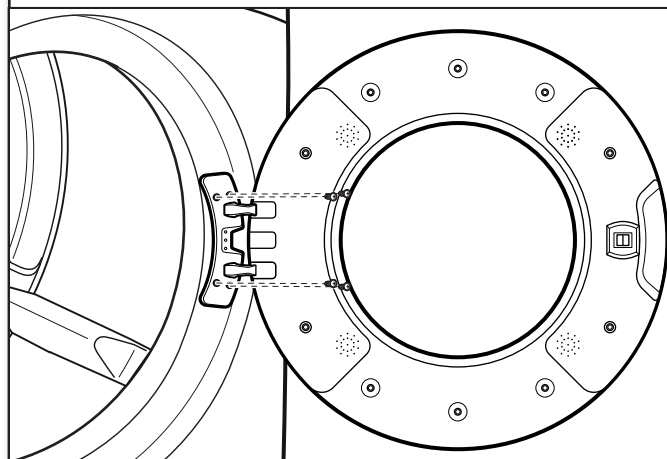

重要事項：若未從乾衣機取下保護膜，繼續作業前請撕下薄膜。
用 T25 螺絲起子取下將門鉸鏈固定在乾衣機上的四顆螺絲，然後抬起並取下門。把門放在柔軟毛巾或其他不會刮傷物品的表面上。

3. 取下門鎖

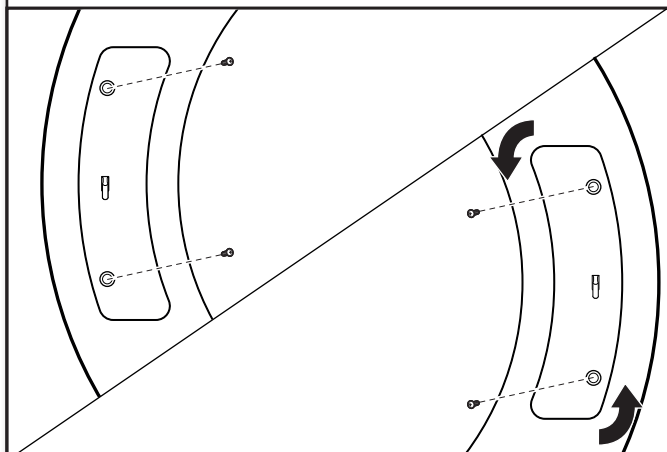

用 T25 螺絲起子取下固定門把至乾衣機門框的兩顆螺絲。180° 旋轉門把，用較早前取下，用以把它裝在門框的兩顆螺絲，重新把它裝在乾衣機門框的另外一邊。

4. 從外門取下內門

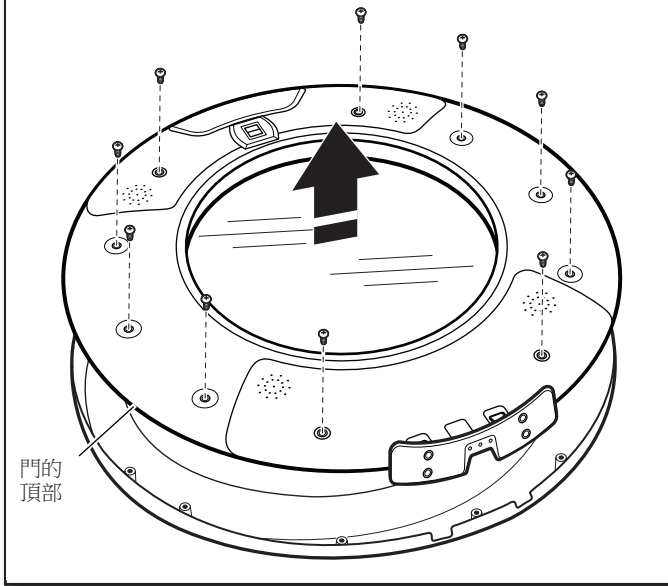

把門放在門內，門面朝上。用十字起子取下把內門裝在外門上的 10 顆螺絲。

5. 取下門鉸鏈

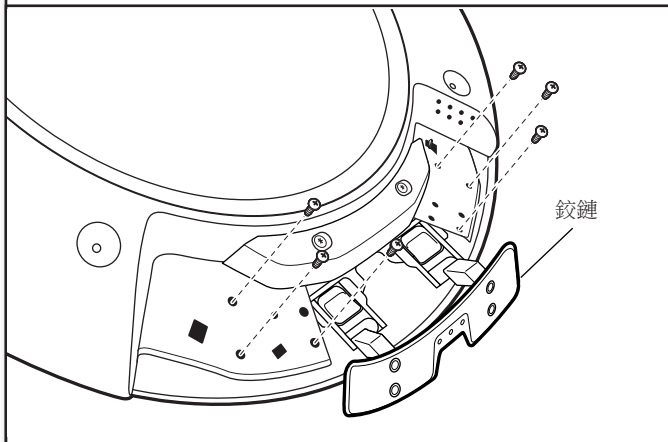

用 T20 螺絲起子取下六顆固定鉸鏈部件的螺絲。

6. 取下門鎖

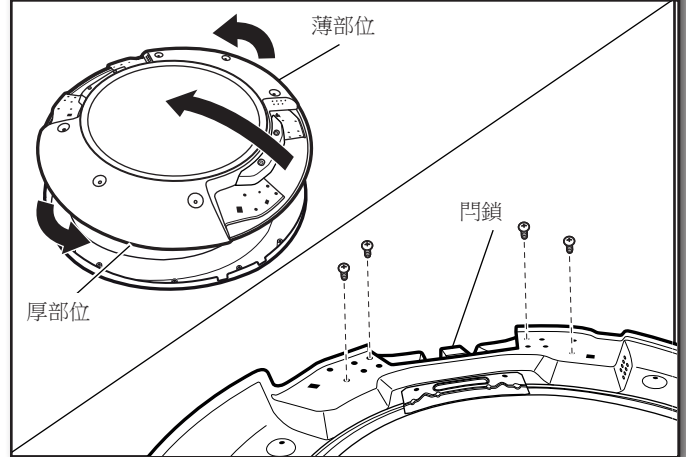

180° 翻轉和旋轉內門，以致於薄部位在頂部，厚部位在抵不住。用 T25 螺絲起子取下四顆固定門鎖板的螺絲。

7. 重新將門鎖裝到另一邊

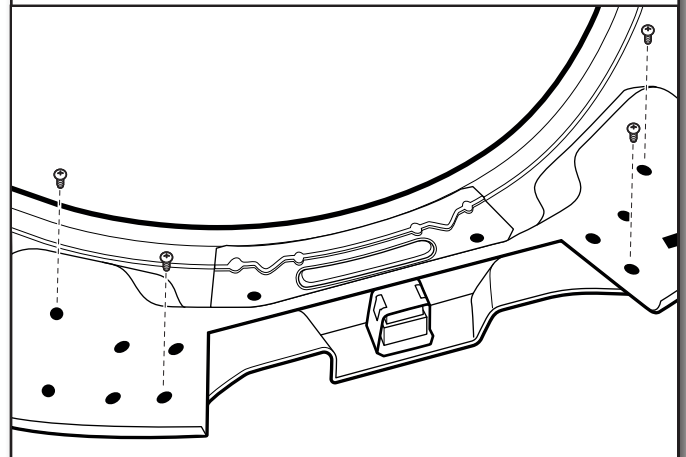

用 T25 螺絲起子和之前取下的四顆螺絲，重新將門鎖板裝到另外一邊。

8. 重新將鉸鏈部件裝到另一邊

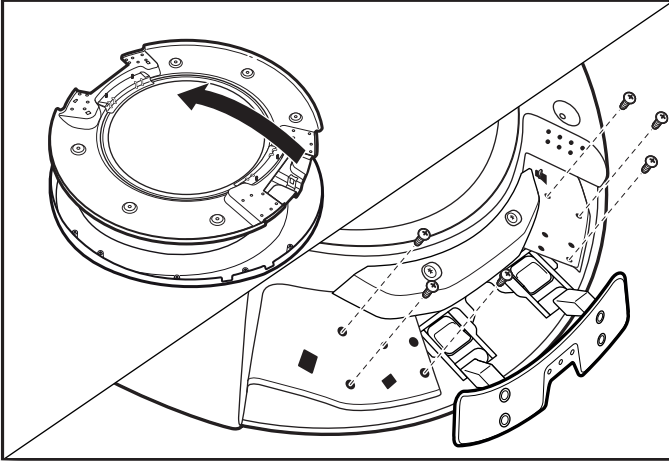

將內門翻轉至左邊。用 T20 螺絲起子重新安裝鉸鏈部件至另外一邊。

10. 重新擺放旋轉部件和管線的位置

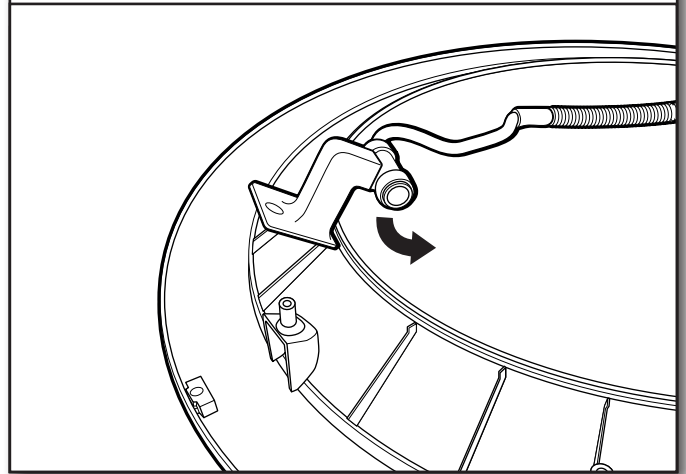

以 180° 的方式，重新擺放旋轉部件和管線至門的另一邊。

帶有電子線路的門：

9. 取下旋轉部件

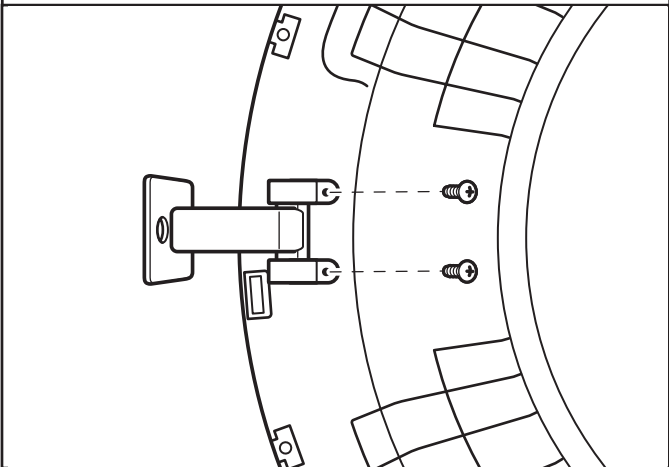

抬起並取下內門部件。用十字起子取下把旋轉部件裝在門上的兩顆螺絲。

11. 旋轉部件的底部，並把它穩妥就定位

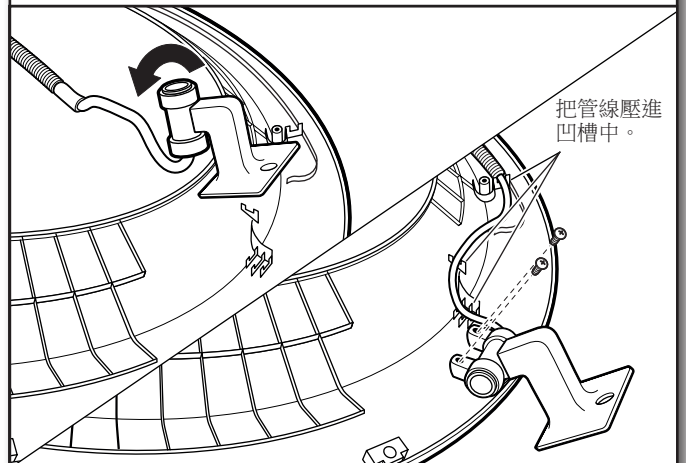

180° 朝著您的方向，旋轉部件的底部，用十字螺絲刀和之前取下的兩顆螺絲，重新安裝部件。把管線壓進凹槽中。

重要事項：確定在旋轉部件的前面將鉸鏈搖下（參閱第 12 步）。

所有門：

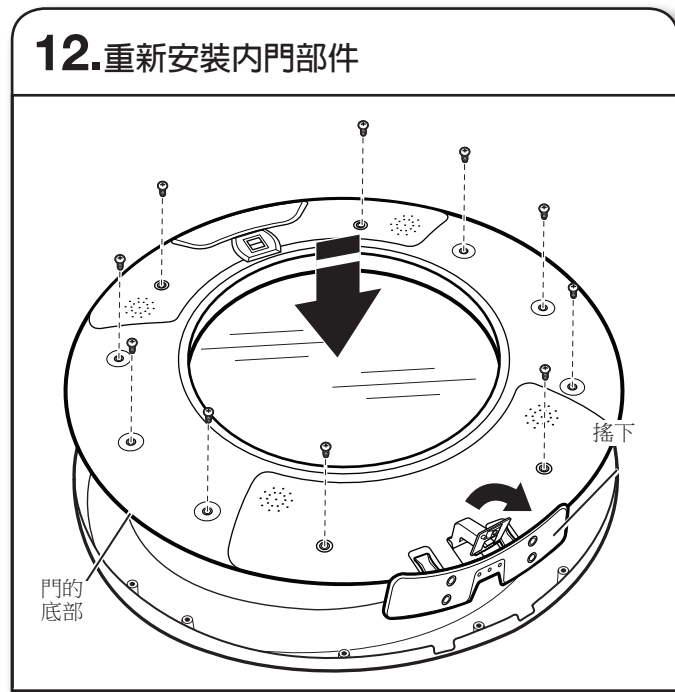

把門放在門內，門面朝上。用十字螺絲刀和之前取下的10顆螺絲，重新將內門裝到外門。

帶有電子線路的門：

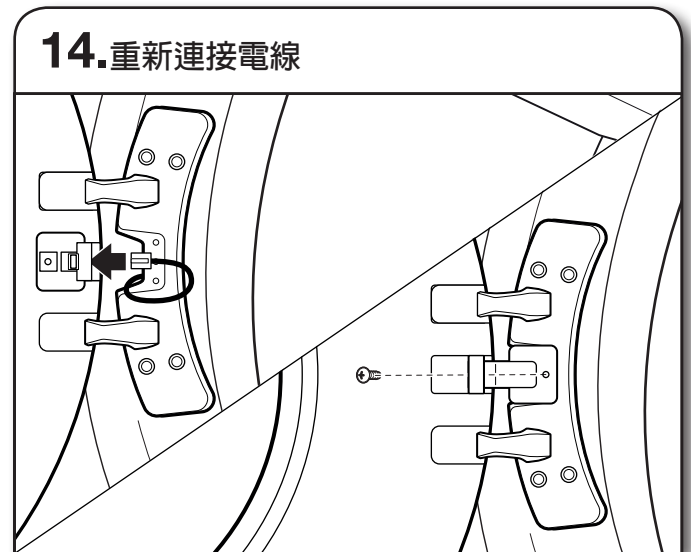

插入電線。用十字螺絲刀和之前取下的螺絲，將旋轉部件裝至鉸鏈上。

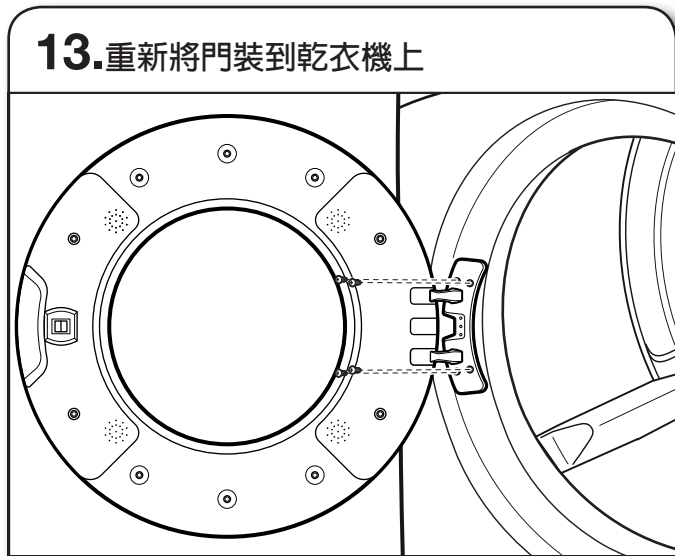

帶有電子線路的門：重新安裝門前，將電線拉過正面面板開口。
將鉸鏈上的螺栓插入安裝槽，在把它們向下滑動，以便處理頂部螺栓。用之前取下的四顆 T25 螺絲把它穩妥就定位。

把門裝到另一邊方形門

1. 取下乾衣機門

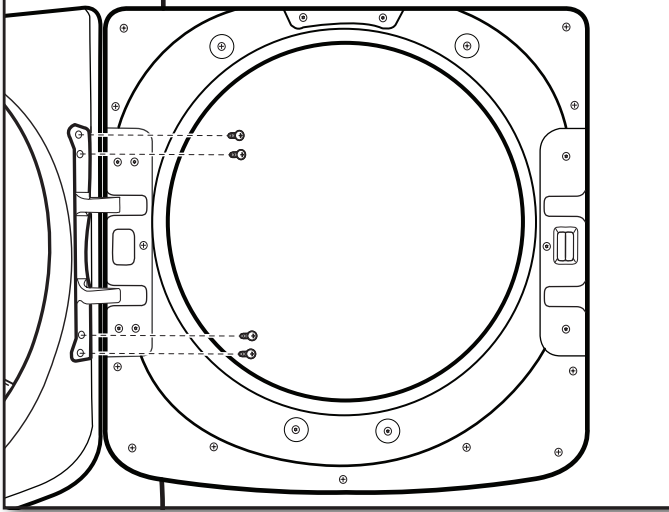

用 T25 螺絲起子取下將門鉸鏈固定在乾衣機上的四顆螺絲，然後抬起並取下門。把門放在柔軟毛巾或其他不會刮傷物品的表面上。保留或把四顆螺絲放在一邊。

2. 取下門鎖

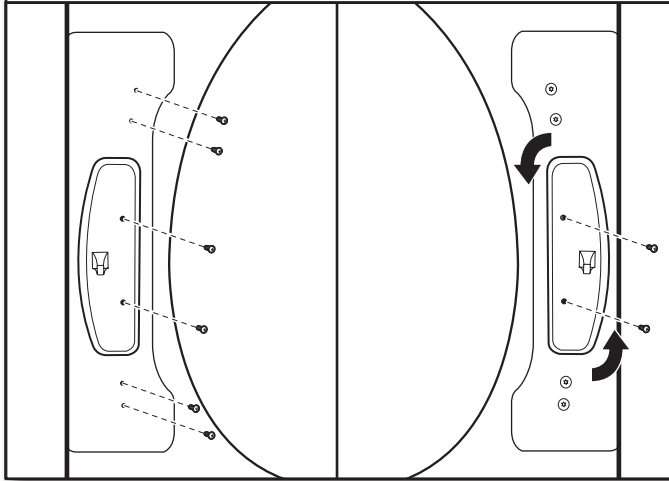

用 T25 螺絲起子取下固定門把至乾衣機門框的兩顆螺絲。取下門鎖上下兩方的四顆螺絲，並把它們放在一邊。180° 旋轉門把，並如圖示，把它裝在乾衣機門框的另外一邊。

3. 從外門取下內門

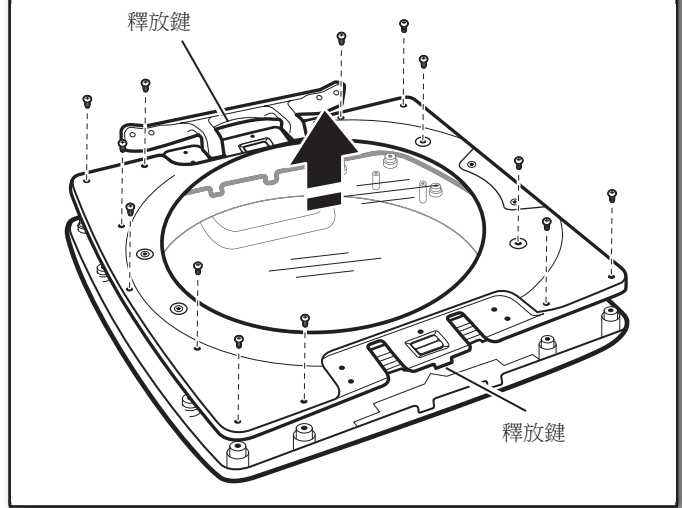

把門放在門內，門面朝上。用十字起子取下把內門裝在外門上的 13 顆螺絲。抬起內門，把它放在一邊。

備註：門的各邊都有一個釋放鍵。若無法輕易分開內門和外門，在內門和外門之間滑進一張信用卡、小刀，或類似的平面物件至所示位置，以鬆開鍵。

4. 從內門取下鉸鏈

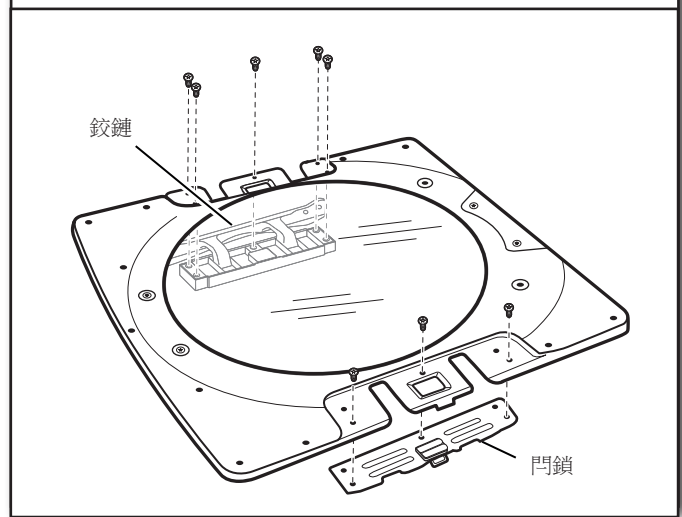

用 T25 螺絲起子，取下三顆固定門鎖板的螺絲，以及安裝鉸鏈部件的五顆螺絲。

5. 重新將鉸鏈和門鎖裝到另一邊

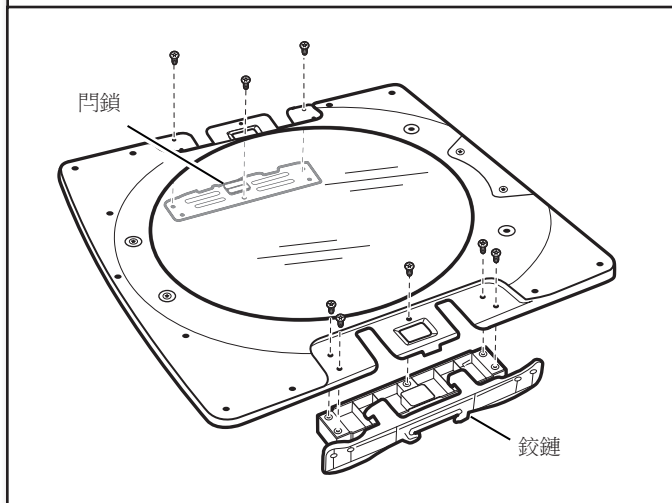

用 T25 螺絲起子重新安裝門鎖板和鉸鏈部件至另外一邊。

7. 重新裝上乾衣機的門

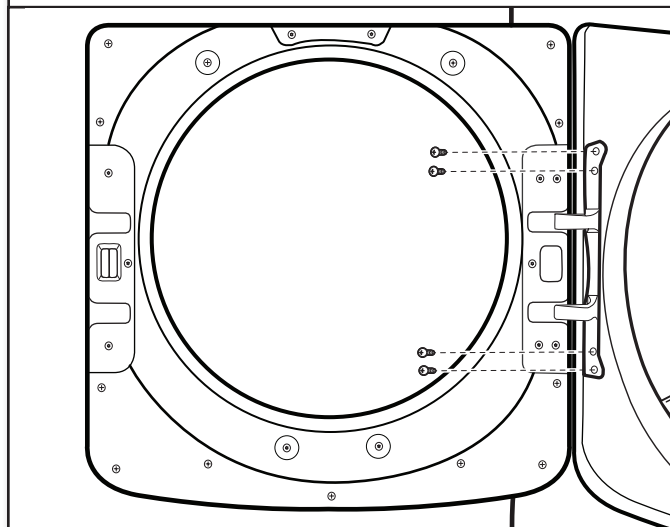

用 T25 螺絲起子再裝上四個螺絲，裝上乾衣機的門鉸鏈。

6. 重新將內門裝至外門

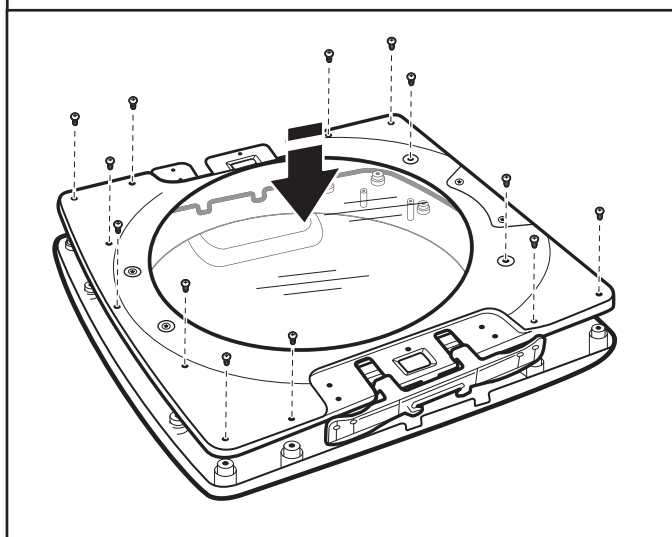

把內門放在外門的部件上。用十字起子裝上先前取下的 13 個螺絲。

NOTES

NOTES

