



## CROSSWAVE® OMNIFORCE™ EDGE MULTI-SURFACE HARD FLOOR CLEANER

3930, 3933, 3934 SERIES

### QUICK START GUIDE

#### 1. Get Ready

Assemble and charge machine (pg 5). If dry cleaning, strainer could be removed for increased tank capacity (pg 6). If wet cleaning, fill the clean water tank (pg 7).

#### 2. Choose Your Cleaning Mode

Press (C) to power on. Choose mode with (B). View selection on (D). When using both modes in one cleaning session, start with Power Vac Mode for dry cleaning and then switch to Power Mop Mode.



##### Power Vac Mode

Great for dry debris on hard floors and area rugs.



##### Power Mop Mode

Efficiently clean wet and dry messes together.

#### 3. Start Cleaning

Recline machine with your foot to start brush roll. For extra fluid and suction, use Turbo Mode (A). For dry and wet cleaning against walls and baseboards, use ZeroGap™ Edge Cleaning (E), located on the right side of the foot.

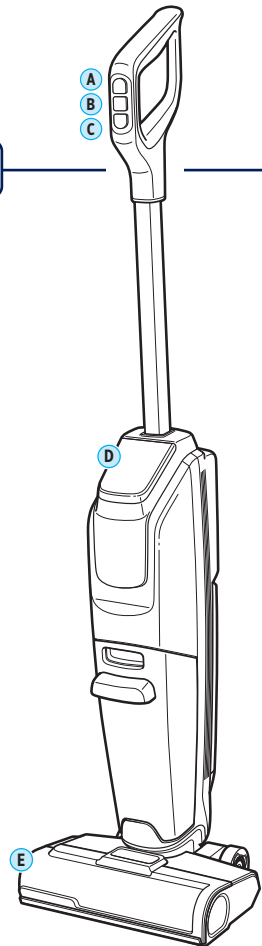

#### CLEANING TIPS

- For best results, use on hard floors and large/heavy area rugs. Follow manufacturer's instructions for small/lightweight rugs.
- If planning to store for over 6 months, ensure the battery is fully charged before storage.

Scan the QR code for product videos, tips, and support.



# IMPORTANT SAFETY INSTRUCTIONS



## READ ALL INSTRUCTIONS BEFORE USING YOUR APPLIANCE.

When using an electrical appliance, basic precautions should be observed, including the following:



## WARNING

### TO REDUCE THE RISK OF FIRE, ELECTRIC SHOCK OR INJURY:

- Use indoors only.
- Do not immerse. Use only on surfaces moistened by cleaning process.
- Use only cleaning products intended for use with this appliance to prevent internal component damage. See the "Power Mop Mode & Compatible BISSELL Formulas" section of this guide.
- Do not allow to be used as a toy. Close attention is necessary when used by or near children.
- Do not use for any purpose other than described in this user guide. Use only manufacturer's recommended attachments.
- Do not charge with damaged charger or plug. If appliance is not working as it should, has been dropped, damaged, left outdoors or dropped into water, have it repaired by a qualified technician.
- Do not pull or carry charger by cord, use cord as a handle, close door on cord, or pull cord around sharp edges or corners. Do not run appliance over cord. Keep cord, docking station and charger away from heated surfaces.
- Do not unplug charger by pulling on cord. To unplug, grasp the charger plug, not the cord.
- Do not handle charger, charger plug, or appliance with wet hands.
- Do not put any object into openings. Do not use with any opening blocked; keep openings free of dust, lint, hair, and anything that may reduce air flow.
- Keep hair, loose clothing, fingers, and all parts of body away from openings and moving parts.
- Turn OFF all controls before plugging or unplugging charger.
- Use extra care when cleaning on stairs.
- Do not use to pick up flammable or combustible materials (lighter fluid, gasoline, kerosene, etc.) or use in areas where they may be present.
- Do not pick up anything that is burning or smoking, such as cigarettes, matches or hot ashes.
- Do not use without filters in place.
- Risk of injury from moving parts. Brush may start unexpectedly. Turn OFF before cleaning or servicing.
- Turn OFF all controls, including the power switch and disconnect charger from electrical outlet before making any adjustments, performing maintenance, troubleshooting, changing accessories, or storing appliance. Such preventative safety measures reduce the risk of starting the appliance accidentally.
- Recharge appliance only with the charger specified by the manufacturer. A charger that is suitable for one type of battery pack may create a risk of fire when used with another battery pack.
- Use only with charger SIL, model SSC-297100US.
- Battery pack, charging port on the appliance and charger output are not to be short-circuited.
- Under abusive conditions, liquid may be ejected from the battery; avoid contact. If contact accidentally occurs, flush with water.
- If liquid contacts eyes additionally seek medical help. Liquid ejected from the battery may cause irritation or burns.
- Do not use appliance that is damaged or modified. Damaged or modified batteries may exhibit unpredictable behavior resulting in fire, explosion or risk of injury.
- Do not expose battery pack or appliance to fire or excessive temperature. Exposure to fire or temperature above 130°C/265°F may cause explosion.
- Follow all charging instructions and do not charge the appliance outside of the temperature range specified in the instructions. Charging improperly or at temperatures outside of the specified range may damage the battery and increase the risk of fire.
- Have servicing performed by a qualified repair person using only identical replacement parts. This will ensure that the safety of the product is maintained.
- Do not modify or attempt to repair the appliance except as indicated in the instructions for use or care.
- Unplug charger from electrical socket when not in use, before cleaning, maintaining or servicing the appliance.
- Keep the temperature range of between 4-40°C/40-104°F when charging battery, storing unit or during use.
- Do not charge the machine outdoors.
- Do not turn your appliance ON until you are familiar with all instructions and operating procedures.
- This appliance contains batteries that are non-replaceable.
- Do not incinerate the appliance even if it is severely damaged. The batteries can explode in a fire.
- The battery must be removed from the appliance before it is scrapped.
- Keep appliance on a level surface.
- Do not carry the vacuum cleaner while it in use.
- Do not use appliance in an enclosed space filled with vapors given off by oil-based paint, paint thinner, some moth-proofing substances, flammable dust, or other explosive or toxic vapors.
- Do not use to pick up toxic material (chlorine bleach, ammonia, drain cleaner, etc.).
- Do not pick up hard or sharp objects such as glass, nails, screws, coins, etc.
- Plastic film can be dangerous. To avoid danger of suffocation, keep away from children.
- Liquid must not be directed towards equipment containing electrical components.
- Prevent unintentional starting. Ensure the switch is in the OFF-position before picking up or carrying the appliance. Carrying the appliance with your finger on the switch or energizing appliance that can turn the switch on invites accidents.
- To reduce the risk of a leaking condition, do not store where freezing may occur. Damage to internal components may result.
- Plastic tanks are not dishwasher safe. Do not put tanks in dishwasher.

## SAVE THESE INSTRUCTIONS

**THIS MODEL IS FOR HOUSEHOLD USE ONLY.**

**COMMERCIAL USE OF THIS UNIT voids the MANUFACTURER'S WARRANTY.**

## IMPORTANT INFORMATION

- Keep appliance on a level surface.
- If your appliance has a motorized brush roll, do not leave machine running in the same spot without the handle fully upright.
- Do not store where freezing may occur.

# ⚠️ WARNING

This product contains Lithium-Ion rechargeable batteries. DO NOT mix Lithium-Ion batteries with general household waste. According to Federal and State regulations, removal and proper disposal of Lithium-Ion batteries is required. For specific battery disposal instructions please contact Call2Recycle at 877-723-1297 or visit [www.call2recycle.org](http://www.call2recycle.org). For full instructions on battery removal for recycling visit [support.BISSELL.com](http://support.BISSELL.com).



**Supplier's Declaration of Conformity 47 CFR Section 2.1077 Compliance Information** Charger for BISSELL model CONTACT: BISSELL Homecare Inc., 2345 Walker Ave. NW, Grand Rapids, MI 49544. Visit [support.BISSELL.com](http://support.BISSELL.com) or call 1-800-237-7691. This device complies with Part 15 of FCC Rules. Operation is subject to the following two conditions: (1) this device may not cause harmful interference, and (2) this device must accept any interference received, including interference that may cause undesired operation. Caution: Any changes or modifications to this unit not expressly approved by the party responsible for compliance could void the user's authority to operate the equipment. NOTE: This equipment has been tested and found to comply with the limits for a Class B digital device, pursuant to part 15 of the FCC Rules. These limits are designed to provide reasonable protection against harmful interference in a residential installation. This equipment generates, uses and can radiate radio frequency energy and, if not installed and used in accordance with the instructions, may cause harmful interference to radio communications. However, there is no guarantee that interference will not occur in a particular installation. If this equipment does cause harmful interference to radio or television reception, which can be determined by turning the equipment OFF and ON, the user is encouraged to try to correct the interference by one or more of the following measures: (1) Reorient or relocate the receiving antenna. (2) Increase the separation between the equipment and receiver. (3) Connect the equipment into an outlet on a circuit different from that to which the receiver is connected. (4) Consult the dealer or an experienced radio/TV technician for help.

## Warranty

Limited 2-year warranty, may vary by state. Visit [support.BISSELL.com](http://support.BISSELL.com) or call 1-800-237-7691 for complete warranty information.

### Terms and Conditions

Your purchase is subject to the BISSELL Terms and Conditions, which includes dispute resolution through arbitration and class waiver. For complete terms or to opt out from arbitration or class waiver, visit [BISSELL.com/terms-of-use](http://BISSELL.com/terms-of-use) or call 1-800-237-7691.



## NOTICE

Disconnecting the battery will destroy the appliance and invalidate the warranty.

## Table of Contents

Important Safety Instructions .....	2	Power Mop Mode .....	7
Product Overview .....	4	Using the Clean-Out Cycle.....	9
Assembly & Charging the Battery .....	5	After-Cleaning Care .....	10
Power Vac Mode .....	6	Troubleshooting .....	11

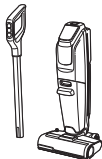
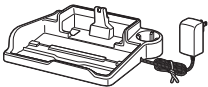
## What's in the Box?

		
Handle & Body	3-in-1 Docking Station	Trial Formula(s)

# Product Overview

## Product Overview

1. Turbo Mode Button
2. Cleaning Mode Button
3. Power On/Off Button
4. Clean-Out Cycle Button
5. Display
6. Dirty Tank
7. Brush Roll Window
8. Clean Water Tank
9. ZeroGap Edge Cleaning Technology

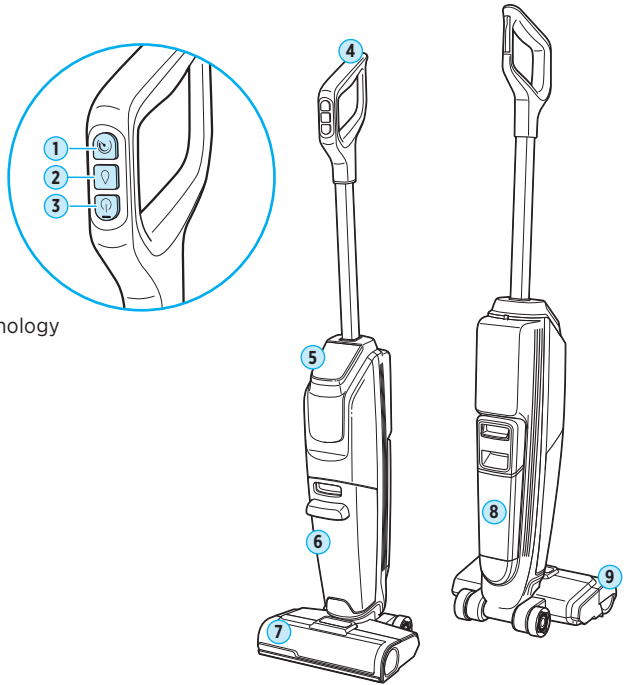

## Display

Note: When machine is docked, screen will be flipped.

1. Dirty Tank Full
2. Error Indicator
3. Charging
4. Low Battery
5. Battery % Remaining
6. Clog Detected
7. Suction Level
8. Fluid Level
9. Brush Roll Stuck
10. Clean-Out Cycle Indicator
11. Clean Tank Empty

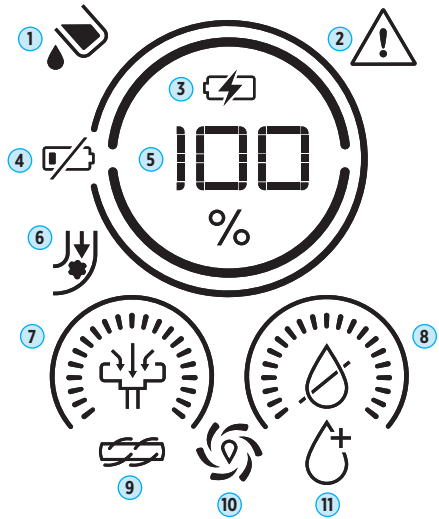

## Assembly & Charging the Battery

**Note:** To activate, make sure machine is fully charged before first use. If machine has been in storage for over 6 months, charge fully before using.



**1.** Firmly insert handle into body of machine until it clicks.

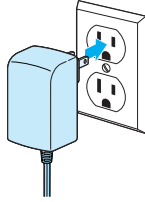

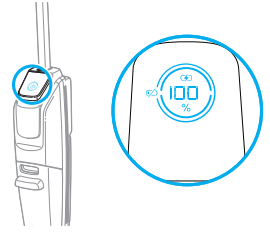

**2.** Plug charging cable plug into the wall.





**3.** Place machine on tray and ensure charging icon is lit up. Let charge for 4 hours or until battery reaches 100% charge.

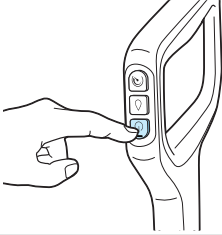

**⚠️ WARNING** To reduce the risk of fire and electric shock due to internal component damage, use only BISSELL cleaning formula intended for use with this machine.

## Power Vac Mode

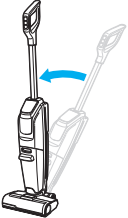
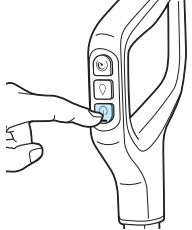
		
<p><b>1.</b> Press power button to turn machine on. Machine will start in dry cleaning mode.</p>		<p><b>2.</b> Recline the machine to start the brush roll spinning. Move the machine back and forth to clean floors.</p>

 <hr/> 		 <p><b>1.5 sec</b></p>
<p>For larger messes and area rugs, switch to Turbo Mode for additional suction.</p>	<p><b>3.</b> Return machine to upright position to stop.</p> <p><b>Note:</b> When powering off or returning upright, machine runs for 1.5 secs to remove debris. Wait for it to finish powering down before moving.</p>	

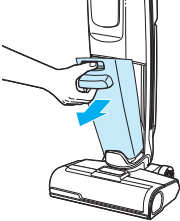
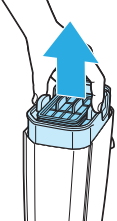
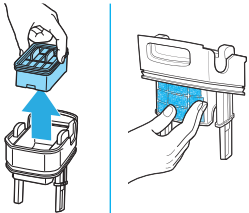
## Emptying the Dirty Tank

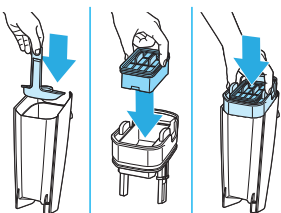
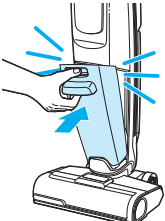

		
<p><b>1.</b> Press button on top of dirty tank and pull out.</p>	<p><b>2.</b> Remove top of tank by grabbing lid in recessed area on either side of filter.</p>	<p><b>3.</b> Remove filter from lid. Remove debris from filter and from mesh screen of lid.</p>
		
<p><b>4.</b> Pull the strainer tab up and remove debris. Empty tank into trash can.</p>	<p><b>5.</b> Replace strainer and place filter into lid. Return lid to dirty tank.</p>	<p><b>6.</b> Insert bottom of tank first. Tilt tank towards machine until it clicks into place.</p>

# Power Mop Mode

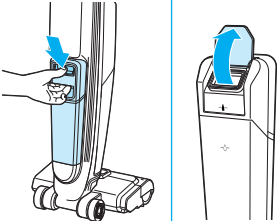
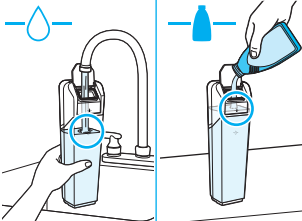
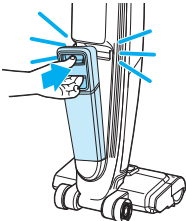
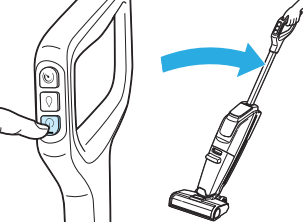
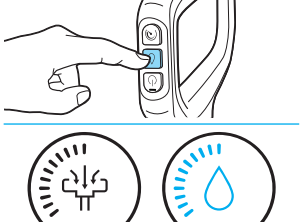
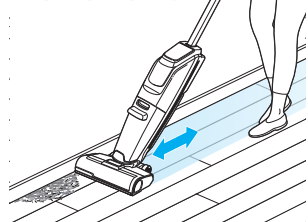
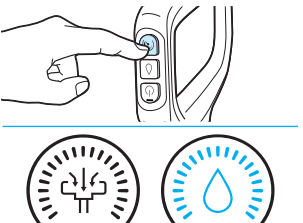

For optimal performance, use genuine BISSELL formulas in your machine\*. Other formulas or household cleaners may cause defects or damage to the machine.

**When using both modes in one cleaning session, start with Power Vac Mode for dry cleaning and then switch to Power Mop Mode since parts need to dry for 24 hours after use.**

		
<p><b>1.</b> Remove clean water tank by pressing latch and tilting tank backward. Open cap on top of tank.</p>	<p><b>2.</b> Fill with warm (140°F/60°C MAX) tap water to fill line. Do not use boiling water. Do not heat water in microwave. Add cleaning formula to formula fill line.</p>	<p><b>3.</b> Close cap until it clicks before installing in the unit. Reinsert bottom of tank and tilt tank toward machine until it clicks.</p>
		
<p><b>4.</b> Press power button to turn machine on. Recline machine to begin cleaning. Return to upright position to stop.</p>	<p><b>5.</b> Press cleaning mode button to switch to Power Mop mode. Wait 10-15 seconds to allow machine to fully wet brush roll.</p>	<p><b>6.</b> For best results, move machine forward to wet floor and backward to extract water.</p>
		
<p><b>7.</b> For larger messes and area rugs, switch to Turbo Mode (A) for additional cleaning fluid and suction.</p>	<p><b>8.</b> When clean water tank is empty, machine will beep and display add water icon. If clean tank is not filled, machine reverts to dry cleaning mode. Remove clean tank and refill.</p>	<p><b>9.</b> If the dirty tank is full, machine will beep and display dirty tank full icon. Empty the tank (pg 8).</p>

\*Compatible BISSELL formulas include: Pet Multi-Surface Formula Lemon-Eucalyptus, Pet Multi-Surface with Febreze® Formula, Pet Simply Multi-Surface Formula, Multi-Surface Formula, Hard Floor Sanitize Formula, Wood Floor Formula, Freshstart™ Clean Out Cycle Formula

Certain trademarks used under license from The Procter & Gamble Company or its affiliates.

CONTINUED ON NEXT PAGE →

## Sanitizing Hard Floors

BISSELL Hard Floor Sanitize formula is for use on hard, sealed floors only. Do not use on carpet or area rugs. Read formula container label fully prior to use.

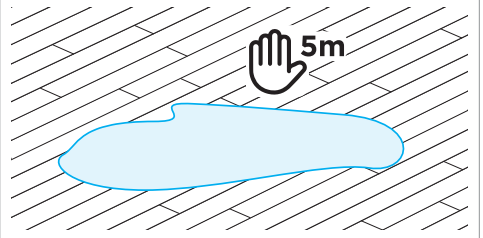

**1.** Follow cleaning instructions on page 7 to remove visible soils.

**To Sanitize:** Using BISSELL Hard Floor Sanitize formula and with machine in Power Mop mode, make forward and backward passes. Solution will dispense automatically.

**2.** Allow floor to remain visibly wet with formula for five minutes. This may require additional passes in Power Mop mode.

## Emptying the Dirty Tank

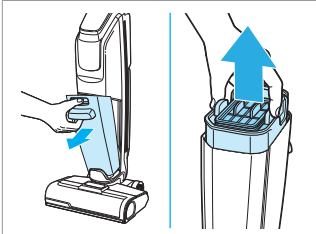

**1.** Press button on top of dirty tank and pull out. Remove top of tank by grabbing lid in recessed area on either side of filter to remove.

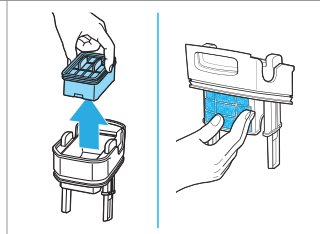

**2.** Remove filter from lid. Remove debris from filter and from mesh screen of lid.

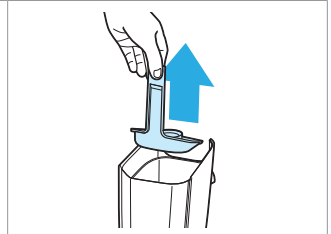

**3.** Pull strainer tab up and out of tank to separate debris from dirty water. Dispose of debris.

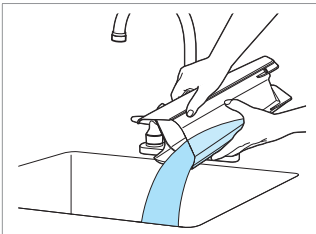

**4.** Pour out dirty water and rinse tank and tank lid.

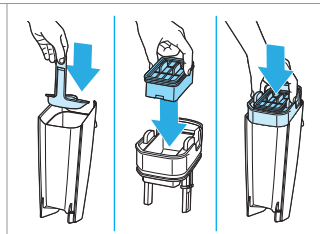

**5.** Replace strainer and place filter into lid. Return lid to dirty tank.

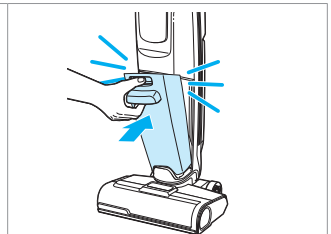

**6.** Insert bottom of tank first. Tilt tank towards machine until it clicks into place.

CONTINUED ON NEXT PAGE ➔



## Using the Clean-Out Cycle

For use after wet cleaning only.

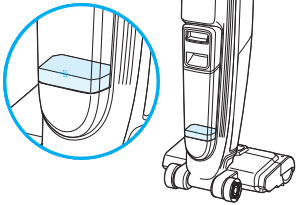
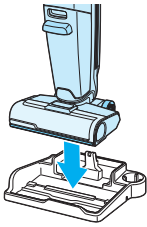
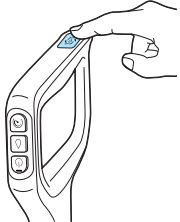
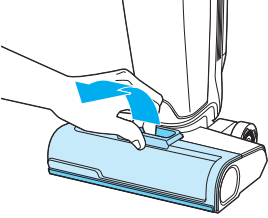
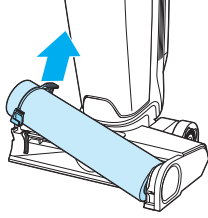
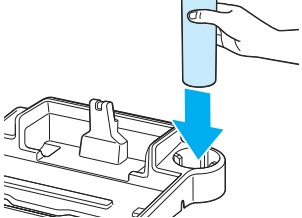



		
<p><b>1.</b> Empty dirty tank. Ensure solution in clean water tank reaches the Clean-Out Cycle line.</p>	<p><b>2.</b> Place the machine on the 3-in-1 Docking Station.</p>	<p><b>3.</b> Push Clean-Out Cycle Button to start 40-second cycle.</p>
		
<p><b>4.</b> To release brush roll window, press button on window and rotate window towards you.</p>	<p><b>5.</b> Pull brush roll tab to remove.</p>	<p><b>6.</b> Place brush roll in brush holder on dock to dry.</p>

**Note:** If brush roll is still dirty, it can be hand washed with mild detergent and place in brush roll holder on charging tray to dry.

For best results, replace brush roll every 3 months.

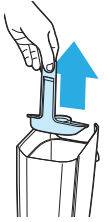
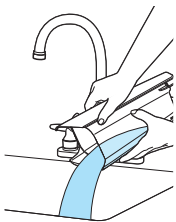
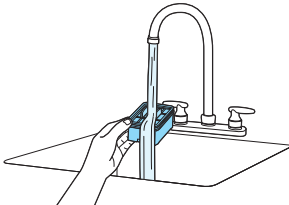
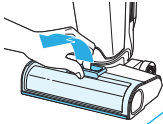
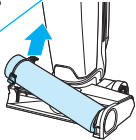
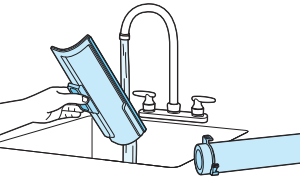
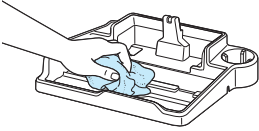
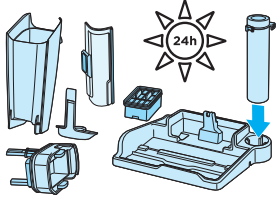
## After-Cleaning Care

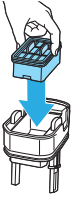
Important: Filter must be cleaned and dried after every use to maximize suction and performance. Replace filter every 3 months.

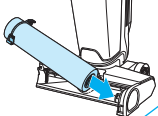
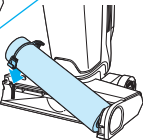
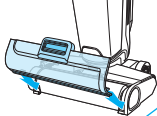
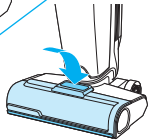
 		 
<p><b>1.</b> Empty and rinse dirty tank and tank lid (pg 8). Remove filter from top of tank by grabbing tabs on filter and lifting up. Remove any debris from under filter.</p>	<p><b>2.</b> Wash filter and screen with warm water and mild detergent. Rinse bottom of tank cover. Rinse all debris from dirty tank cover.</p>	<p><b>3.</b> Press button to release brush roll window. Pull brush roll tab to remove.</p>
		
<p><b>4.</b> Hand wash brush roll and window with water and mild detergent.</p>	<p><b>5.</b> Remove machine from dock to wipe out tray. Do not rinse tray under faucet to avoid water entering charging plug.</p>	<p><b>6.</b> Leave all parts out to dry for 24 hours before reassembling.</p>
  	 	 
<p><b>7.</b> Replace lid and strainer on dirty tank, the filter at the top. Insert bottom of tank into machine first. Tilt tank towards machine until it clicks into place.</p>	<p><b>8.</b> Insert right side of brush roll first and rotate downward until tab on left side of brush is locked in place.</p>	<p><b>9.</b> Reinstall window by lining up tabs on bottom edges of foot and rotating towards machine. Press down until window clicks into place.</p>

**Note:** Any other maintenance or servicing not included in this manual should be performed by an authorized service representative.

# Troubleshooting

Problem	Possible Cause	Remedies
Striking or loss of suction power	Brush roll window is not latched.	Reinstall brush roll window.
	Debris channel in foot is clogged.	Clean channel with a paper towel.
	Filter is clogged and/or is wet.	Remove debris clogging the screen, then clean and dry filter.
	Mesh screen in dirt tank is clogged.	Remove debris from mesh screen and empty tank.
	Filter is clogged.	Remove filter and remove any debris from filter screen or underneath the filter.
	Filter is wet.	Check screen and paper pleats for moisture. Allow to dry for 24 hours before reinstalling.
	Brush roll is wet and dirty.	Clean and dry brush roll.
Leaking	Clean water tank or lid is damaged.	Remove tank from machine and inspect for damage on tank and/or lid. If damage is found, contact BISSELL Consumer Care.
	Dirty tank is damaged.	Remove tank from machine and inspect for damage. If damage is found, contact BISSELL Consumer Care.
	Dirty tank is full.	Empty tank.
Clean-Out Cycle not working	Machine is not on storage tray.	Place machine on storage tray.
	Clean tank low.	Refill tank.
	Dirty tank is full.	Empty tank before starting the Clean-Out Cycle.
Brush roll not spinning	Hair stuck on end of brush roll or by brush roll tab.	Remove brush roll from machine and clean any hair from the end of the brush roll and from foot. Rotate the small section of the brush roll clockwise to remove and clean any hair from brush tab. Rotate counter-clockwise to reinstall.

Error Code	Possible Cause	Remedies
E1	System clog	Remove brush roll window and brush roll to check for clogs. Inspect dirty tank inlet for clogs. Clean the filter. Remove debris from the dirty tank screen.
E2	Brush roll stuck	Remove brush roll window and brush roll to check for debris in foot. Remove any accumulated hair from brush roll.
E3	Fan error	Contact BISSELL Consumer Care.
E4	Battery communication error	Contact BISSELL Consumer Care.

The battery is to be disposed of safely. See support.BISSELL.com for battery removal instructions.



BISSELL proudly supports BISSELL Pet Foundation® and its mission to help save homeless pets. When you buy a BISSELL® product, you help save pets, too. We're proud to design products that help make pet messes, odors and pet homelessness disappear.

Visit [BISSELLsavespets.com](https://www.bissellsavespets.com) to learn more.

## Need more support?

Head to [support.BISSELL.com](https://support.bissell.com) to troubleshoot, register your product, order spare parts, view your warranty, and more.



REGISTER



INFO



VIDEOS



PARTS



SUPPORT



©2024 BISSELL Inc. All rights reserved.  
Part Number 1640878 03/24 v8