



NIKOLATESLA *Series*

Induction Technology with Integrated Aspiration

 **elica**
aria nuova

—| INTRODUCING: NIKOLATESLA Series

NIKOLATESLA PLUS FEATURES



BRIDGE ZONES



The special Bridge Zones can work both individually or combined for a more homogenous cooking using both baking pans and large pots. Thanks to this technology it is the cooktop's surface that adapts itself to the type of pots being used.



AIRMATIC



The auto aspiration adjusts automatically to the number and power of the used cooking zones.



CERAMIC FILTERS



This recirculating filter is suitable for the most challenging cooking environment, given its superior ability to filter and purify the air. The new Elica Technology is able to achieve filtering threshold of 82% against the market average of 60%. it can be regenerated up to 5 years if placed in oven at 390° F for 45 minutes every 2/3 months.



POT DETECTOR



Automatically detects a pot on a cooking zone and sends a signal to the hood. Elica hoods with STREAM technology will turn on automatically.



TEMPERATURE MANAGER



Cooked dishes will always be perfect when you use this function that lets you set the cooktop with three programs (100°, 160°, and 200° F) the temperature has been optimized for both very delicate cooking (mousse, sauces, keeping dishes warm) as well as cooking at high power (boiling)



STOP&GO



If you are interrupted while cooking, or you have to go into another room, or you just want a break, with just a single movement, pressing the Stop&Go button, you can switch off all the cooking zones and walk away with complete confidence and safety.

NIKOLATESLA Series

FOR THOSE WHO LIKE THINKING OUTSIDE THE BOX:

SPACE SAVING DESIGN

NikolaTesla not only integrates perfectly within the kitchen without obstructing your view, but also, thanks to its slim design optimizes the space under the unit allowing the addition of drawers or useful cabinet space.

AIRMATIC FUNCTION

NikolaTesla Smart Sensor Technology is able to detect heat and humidity levels and automatically adjusts the fan speed to fit your cooking needs.

EASY CLEANING

The completely smooth surface of the NikolaTesla simplifies cleaning. In addition, the dishwasher safe exclusively designed grease filter can be accessed from the top of the surface. Any spilled liquids during cooking will be captured in the cavity below the grease filter and can be easily removed by opening the drain valve and wiping out any residual with a cloth. In the recirculating version, the high performing new generation ceramic odor filters are accessible from the top part of the cooktop, making cleaning and maintenance a cinch.

NIKOLATESLA SWITCH

EUROPEAN
PRODUCT
DESIGN
AWARD

IDA
DESIGN
AWARDS
2019
WINNER

IDEX
INTERNATIONAL DESIGN
EXCELLENCE AWARDS 2018
FINALIST

Cooktop Dimensions: 36" x 20 1/16" x 8 1/4"
Each Burner Dimensions: 4 (2,1 - 3,7kW) - 7,1 x 7,9 inches



REVOLUTIONARY COOKING

INDUCTION TECHNOLOGY WITH BUILT-IN ASPIRATION THAT COMBINES ITALIAN DESIGN WITH FUNCTIONALITY

NikolaTesla Switch is the latest Induction Cooktop with built-in Aspiration by Elica, with innovative functions and unique performance, representing the highest expression of technology and design.

Available in a sophisticated black ceramic glass finish and measures 36" in width. The central disk which allows 360°- degree rotation has two exterior finishes - on one side is black glass and on the other is steel. When closed on either side (black glass or steel), the central disk is completely flush with the cooktop surface, cleverly concealing the aspiration system. High CFM performance, approximately 5 times faster than the speed of rising fumes, ensures efficient fume and moisture extraction. Duct-out and recirculating versions.



NIKOLATESLA SWITCH

The completely smooth surface of the NikolaTesla simplifies cleaning. In addition, the dishwasher safe exclusively designed grease filter can be accessed from the top of the surface. Any spilled liquids during cooking will be captured in the cavity below the grease filter and can be easily removed by opening the drain valve and wiping out any residual with a cloth.

In the recirculating version, the high performing new generation ceramic carbon filters are accessible from the top of the cooktop, making cleaning and maintenance a cinch.

Fits seamlessly into any design concept for your kitchen. Elica's aspiration cooktops have been designed to guarantee maximum installation flexibility, leaving enough space for undercabinet storage thanks to movable ducting.



Completely invisible Aspiration System, turn it on and off with a Switch.

Note: As a security measure, it is not recommended to install any other type of electric appliance, like dishwashers or ovens, in the free space underneath NikolaTesla.

EXCLUSIVE PLUS FEATURES



AIRMATIC



BRIDGE ZONES



ODOR FILTERS



STOP&GO



TEMPERATURE MANAGER



POT DETECTOR



Touch Controls, fully control each cooking zone with the tip of a single finger.

LINE DRAWING

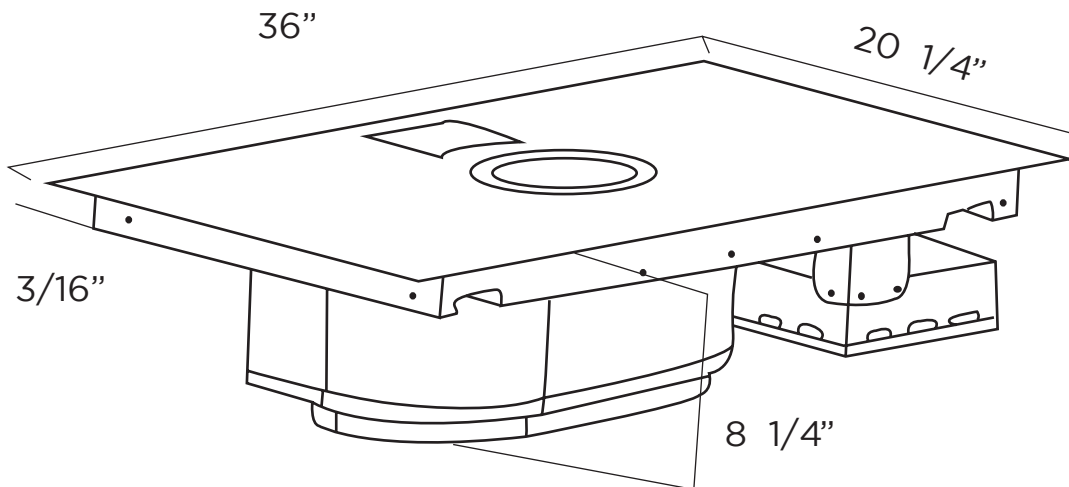

ASPIRATION SYSTEM

	Duct-Out	Recirculating
Controls	Direct Slider 8 Speeds + 2 Boost levels	Direct Slider 8 Speeds + 2 Boost levels
Blower Type	400 CFM	400 CFM
Suction speed	5.1 m/s	5.1 m/s
Noise (sones)	2.2 - 5	2.2 - 5
Ventilation	160 W	160 W
Exit	6"	6"

INDUCTION COOKTOP

Power Consumption	7.4 kW
Electrical Frequency	50 - 60 Hz
Voltage	220 - 240 V
Cooking Zones	4
Each Burner Dimensions	7,1 x 7,9 inches
Each Burner Power	2,1 - 3,7kW
Boost Power	3,7kW
Bridge Zones	2

FUNCTIONS

EGG TIMER/ SPECIAL TIMER
 CHILD LOCK
 TEMPERATURE MANAGER
 STOP & GO
 AUTOMATIC HEAT UP
 WARMING FUNCTION
 POT DETECTOR
 SAFETY SHUT DOWN
 POWER LIMITATION
 RESIDUAL HEAT INDICATOR
 BRIDGE ZONES

Bridge Zones Power: Each induction module can supply max 3.7kW, so the 2 cooking zones connected to the same induction module can't be setted up at booster level together (3.7 + 3.7 per module)

MODEL



MODEL

NIKOLATESLA SWITCH 36" ENTS436BLO Black Tempered Glass

PARTS INCLUDED

Qty 1 - 6 layer anodized aluminum mesh grease filter (pre-installed)
 Qty 1 - Ducted Out cartridge (pre-installed)
 Qty 1 - Recirculation cartridge
 Qty 4 - Ceramic carbon filters and removal ribbon
 Qty 1 - Reducer Joint
 Qty 1 - 3 " x 10" short metal duct transition
 Qty 1 - 3 " x 10" long metal duct transition
 Qty 1 - Joint Tape
 Qty 1 - Hardware Pack (contains mounting clips, seam tape, installation instructions)

NIKOLATESLA ONE



Compasso d'Oro 2018



Cooktop Dimensions: 32 1/16" x 20 1/16" x 8 1/4"
Each Burner Dimensions: 4 (2,1 - 3,7kW) - 7,1 x 7,9 inches



FUNCTIONALITY AND INNOVATION

ELICA 'S FIRST INDUCTION COOKTOP WITH TECHNOLOGY INTEGRATED, COMBINING TWO KITCHEN APPLIANCES INTO ONE



With the advantages of cooking speed and easy maintenance common with induction cooktops, NIKOLATESLA ONE adds central ventilation for high performance capture of grease, smoke and odor.

Completely invisible Aspiration system, that can be easily controlled with the touch of your finger.

NIKOLATESLA ONE

The aspirating system, positioned in the central zone, reaches high performance levels, in terms of fume extraction, noise level and energy efficiency. Thanks to the direct communication with the cooktop, it is able to receive information from the cooking zones, and automatically calibrates the ideal aspiration level, so that the user only needs to worry about cooking, while at the same time reducing energy consumption.

With filters included the NikolaTesla One can be installed as ducted or recirculated.

EXCLUSIVE PLUS FEATURES



AIRMATIC



BRIDGE ZONES



ODOR FILTERS



STOP&GO



TEMPERATURE MANAGER



POT DETECTOR



Grease filter easily removed from top of cooktop and are dishwasher safe. Charcoal filters are easily removable and recharged in the oven (recirculating installation).



Drain valve can be opened to remove any residue or spilled liquid.

LINE DRAWING

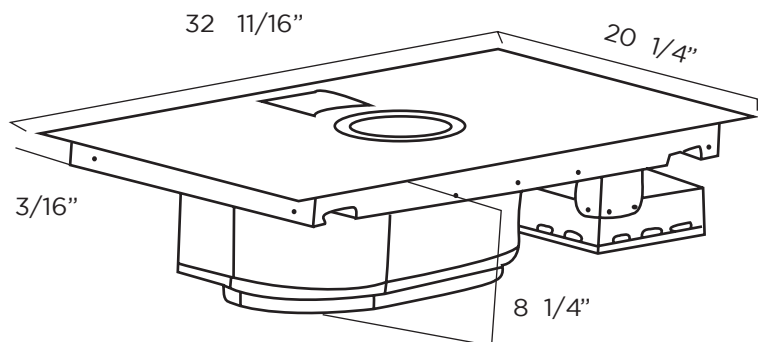

TRIM KIT DIMENSIONS

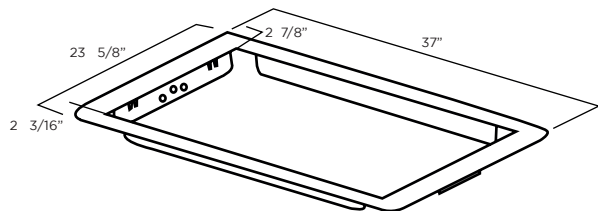

MODEL

FUNCTIONS

EGG TIMER/ SPECIAL TIMER
CHILD LOCK
TEMPERATURE MANAGER
STOP & GO
BRIDGE ZONES
AUTOMATIC HEAT UP
WARMING FUNCTION
COOKING ZONE TIMER
POT DETECTOR
SAFETY SHUT DOWN
POWER LIMITATION



MODEL

NIKOLATESLA HP 33" ENT432BL Black Glass
TRIM KIT 36" KIT0155746 Stainless Steel

INDUCTION COOKTOP

Power Consumption	7.4 kW
Electrical Frequency	50 - 60 Hz
Voltage	220 - 240 V
Cooking Zones	4
Each Burner Dimensions	180x200 mm
Each Burner Power	(2.1 - 3.7 kW)
Boost Power	3.7 kW
Bridge Zones	2

ASPIRATION SYSTEM

	Duct-Out	Recirculating
Controls	Direct Slider 9V+1I	Direct Slider 9V+1I
Blower Type	400 CFM	400 CFM
Suction speed	5.1 m/s	5.1 m/s
Noise (sones)	2.2 - 5	2.2 - 5
Ventilation	160 W	160 W

PARTS INCLUDED

Qty 1 - 6 layer anodized aluminum mesh grease filter (pre-installed)
Qty 1 - Ducted Out cartridge (pre-installed)
Qty 1 - Recirculation cartridge
Qty 4 - Ceramic carbon filters and removal ribbon
Qty 1 - Reducer Joint
Qty 1 - 3" x 10" short metal duct transition
Qty 1 - 3" x 10" long metal duct transition
Qty 1 - Joint Tape
Qty 1 - Hardware Pack (contains mounting clips, seam tape, installation instructions)

INSTALLATION TYPE

NIKOLATESLA has been designed to adapt to different types of kitchens (All ducting should be supplied by installer).

TRADITIONAL INSTALLATION

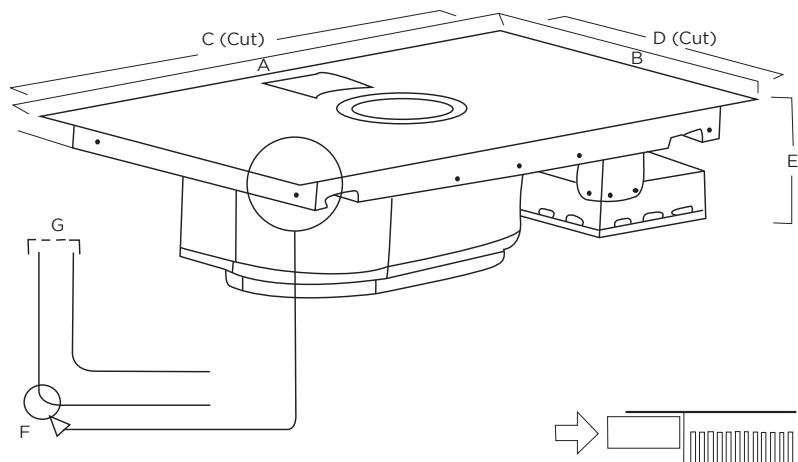

ONE	
A	32 11/16"
B	20 4/16"
C	31 31/16"
D	19 6/16"
E	8 4/16"
F	7/16"
G	Min 1 15/16"

SWITCH	
A	36 1/16"
B	20 4/16"
C	31 31/16"
D	19 6/16"
E	8 4/16"
F	7/16"
G	Min 1 15/16"

In its Duct-Out version, having installed the ducts outside the cabinets is optional, user can choose the ideal configuration according to its needs.

FLUSH MOUNTED

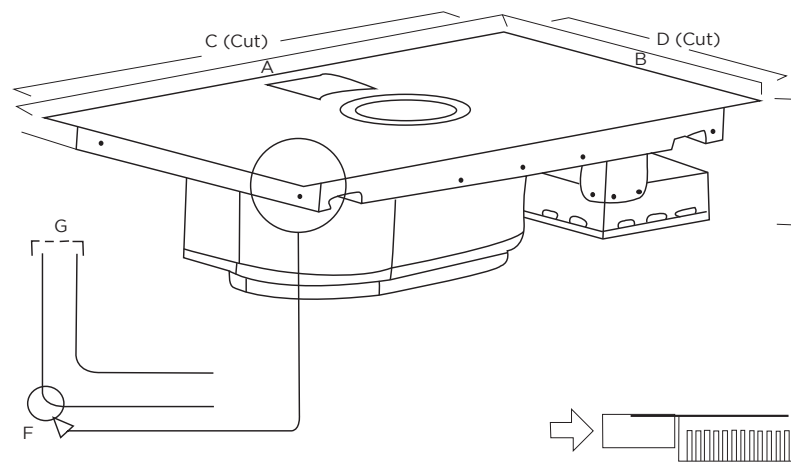

ONE	
A	32 15/16"
B	20 8/16"
C	31 31/16"
D	19 6/16"
E	8 4/16"
F	9/32"
G	7/16"

SWITCH	
A	36 1/16"
B	20 8/16"
C	31 31/16"
D	19 6/16"
E	8 4/16"
F	9/32"
G	1/2"

DUCT-OUT

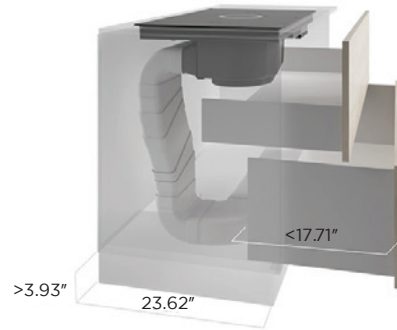

For the Duct-Out version installation, it will be necessary to leave a high stand of 3.93" to allow space to the ducts on the ground.

RECIRCULATING

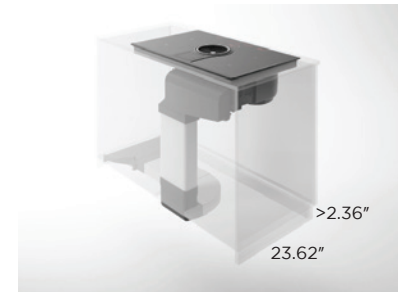
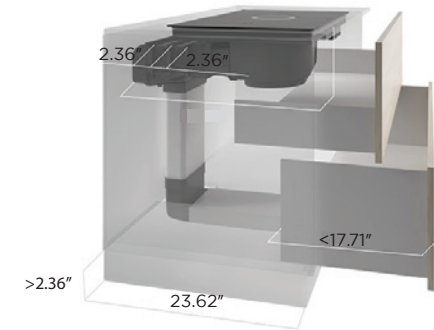
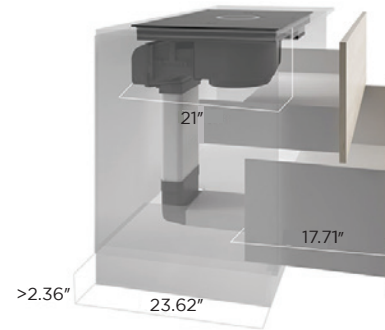

Please note, most ducting insulation provided by the installer are rigid, images may vary from final installations results according to each user needs.

REALIZED BY
ELICAMEX MARKETING TEAM

Typographic printing does not always reproduce original colors and materials faithfully.

Elica reserves the right to make changes to the data and details of the products in this catalogue, even without notice.

JUNE 2020



EARN A 3RD YEAR OF FULL FACTORY WARRANTY

COVERING ALL PARTS PLUS
IN-HOME LABOR.

FOR U.S & CANADA USERS ONLY

By registering the NIKOLATESLA cooktop on the elica.com site, warranty is extended free of charge for 3 years. No additional costs for parts or in-home labor. Only at certain Elica authorized service centers. For valid warranty extension, register within 3 months form purchase.

<https://elica.com/US-en/register-product>

3 YEAR
FULL
WARRANTY



DISCOVER MORE
elica.com

