

SKSCF3001P

30-INCH INTEGRATED COLUMN FREEZER

SIGNATURE
KITCHEN SUITE



LARGEST CAPACITY COLUMN

Designed to provide the largest capacity in the industry*, the 30-inch Integrated Column Freezer features 17.8 cu. ft. of storage capacity.

TRUEFIT™ INTEGRATED DESIGN

Every integrated column features an intelligent, symmetrical design that allows for proud or flush installation, along with easy door reversal.

BRILLIANT INTERIOR

The glass and metal interior is not only beautiful, it is designed to help the freezer stay at the set temperature by holding and transferring cold fast and efficiently.

DISTINCTIVE ICE

The frustum ice shape gives an air of distinction while the removable clear bin holds up to 5.5 lbs., perfect for entertaining.

ECO FRIENDLY

Engineered to reduce environmental impact with HFC / HCFC free refrigerant, insulation and recyclable materials.

*Based on survey of comparable products performed June 1, 2018

Style

Door Style	Panel Ready
Interior Cabinet Finish	Metal

Innovation

Wi-Fi-Enabled for SmartThinQ® Control with iPhone / Android App	Yes
Inverter Linear Compressor	Yes

Performance

Speed Freeze	Yes
Adaptive Defrost	Yes

Modes

Sabbath, Ice Plus, Demo, Icemaker On / Off, Power On / Off, Temp Control, Water Filter Reset, Smart Diagnosis, WiFi, Smart Grid

Water Filter (6 Months)	Yes
-------------------------	-----

Capacity and Storage

Total Capacity (cu. ft.)	17.8
Storage Shelves	3 Adjustable w/ LED True-View™ Lighting, 1 Fixed
Lift and Go™ Ice Drawer	1 Soft Close / Self Close
Lift and Go™ Storage Drawers	3 Soft Close / Self Close
Aluminum Framed Lift and Go™ Door Bins with Removable Inserts	4 Adjustable
Removable Ice Bucket Storage Volume	5.5 lbs.

© 2019 Signature Kitchen Suite. All rights reserved. Design, features and specifications are subject to change without notice. Specifications are for planning purposes only. Consult the product's installation instructions for final dimensional data and other details prior to making cutouts or custom panels. Consult with a heating and ventilation engineer for your specific ventilation requirements. Non-metric weights and measurements are approximate. Smart features require Internet access.

1-855-790-6655 | www.signaturekitchensuite.com

SKSCF3001P

30-INCH INTEGRATED COLUMN FREEZER

SIGNATURE
KITCHEN SUITE

General Features

Digital Controls w/White LED Display	Yes
Water Filter Indicator	Yes
Ice Production (24 Hrs.)	3.5 lbs.
Ice On/Off	Yes
Hidden LED Interior Lighting	Yes
Operating Temperatures	-6° to 8° F
Maximum Sound Level (dBA)	39 dBA
Star-K Certified Sabbath Mode	Yes
ENERGY STAR® Qualified	Yes

Installation Features

Reversible Door	Yes
Four Point Front Adjustable with 8 Wheels	Yes
Attachment Method to Cabinetry	Top with No Visible Screws
Front Serviceable	Yes
Anti-tip Bracket Included	Yes
Unification Kit Included (SKSFJ800P)	Yes

Technical Specs

Required Power Supply	115 V, 60 Hz, 15 or 20 Amp
Plug Type	3-Prong
Power Cord Length	86 1/2"

Dimensions and Weight

Overall Width (inches)	29 3/4"
Overall Height (inches)	83 1/2" Min. – 84 1/2" Max.
Overall Depth Without Panel or Handles (inches)	23 7/8"
Net Weight (approx.)	403 lbs.
Shipping Weight (approx.)	457 lbs.

Optional Accessories

Stainless Steel Panel / Handle / Toekick Kit	SKSPK305CS
Retrofit Frame Kit	SKSFK800CS
Brushed Aluminum Handle Medium – 31 11/16"	SKSHK310HS
Long – 48" (For Columns)	SKSHK480HS
Replacement Water Filter	LT1000P-S

Warranty Summary*

Limited Warranty, Parts & Labor	2 Years
Additional 1 Year When Product Registration is Completed Online with Owner Opt-in for Wi-Fi Monitoring	Yes
Limited Warranty on Sealed System, Parts and Labor	5 Years
Limited Warranty on Sealed System, Parts Only	10 Years

*These warranties give you specific legal rights and you may have other rights that vary from state to state. For complete warranty details, refer to your Use & Care manual.

SKSCF3001P

30-INCH INTEGRATED COLUMN FREEZER

CUTOUT DIMENSIONS – FLUSH OR PROUD INSTALLATION

SINGLE COLUMN

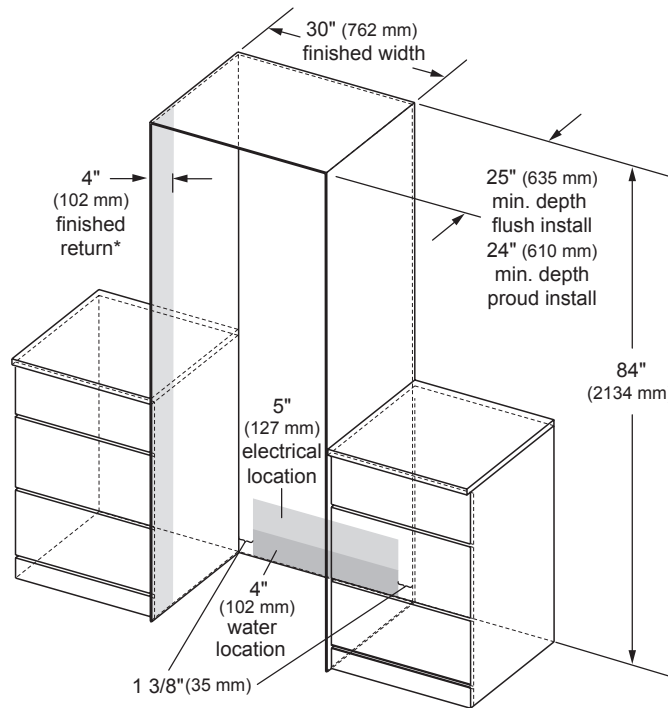

*A minimum 4" (102 mm) finished return that matches the cabinet exterior is recommended on all sides and the top of the cutout opening. The shaded area will be visible after installation.

Notes

Freezer can be installed flush or proud with 3/4" custom panel or optional stainless steel panel kit.

Flush – With a 25" (635 mm) cutout depth, the front face of the freezer fits flush with 25" (635 mm) depth adjacent cabinets.

Proud – With a 24" (610 mm) depth cutout, the front face of the freezer extends approximately 3/4" (19 mm) beyond 24" (610 mm) depth adjacent cabinets.

Electrical

A 115V, 60Hz., 15 or 20 amp power supply is required. An individual properly grounded branch circuit or circuit breaker is recommended. Install a properly grounded 3-prong electrical receptacle recessed into the back wall. Electrical must be located on rear wall as shown.

Note: GFI (ground fault interrupter) is not recommended.

Water Line

A cold water supply is required for automatic icemaker operation. Water pressure must be between 20 and 120 p.s.i.

Tubing should be long enough to extend to the front of the freezer. Allow enough tubing to accommodate a bend leading into the water line connection.

Water line can enter an opening through floor or back wall.

Install a shut-off valve between the icemaker water valve and cold water supply in the home.

INSTALLATION CLEARANCES

TOP VIEW

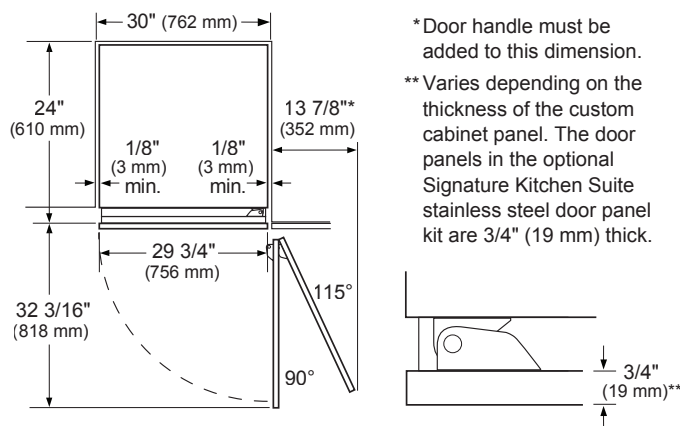

Notes

Door Swing Clearances – The installation must allow for clearances to adjacent walls or cabinets. This freezer is equipped with a 2-position door stop. The factory-set 115° door swing can be adjusted to 90° if clearance to adjacent cabinets or walls is restricted.

Door Handle Clearances – The Door Handle depth must be added to the dimension noted to determine the total clearances required from adjacent cabinets or walls. This clearance will vary depending on the custom handle used. When using the Stainless Steel Door Panel Kit w/Handle or the Brushed Aluminum Handle (optional accessories), the door handle clearance with door open 115° is 16" (406 mm).

SKSCF3001P
30-INCH INTEGRATED COLUMN FREEZER

OVERALL PRODUCT DIMENSIONS

FRONT VIEW

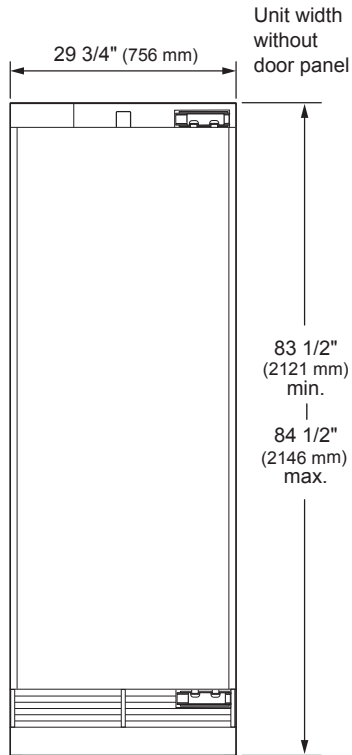

SIDE VIEW

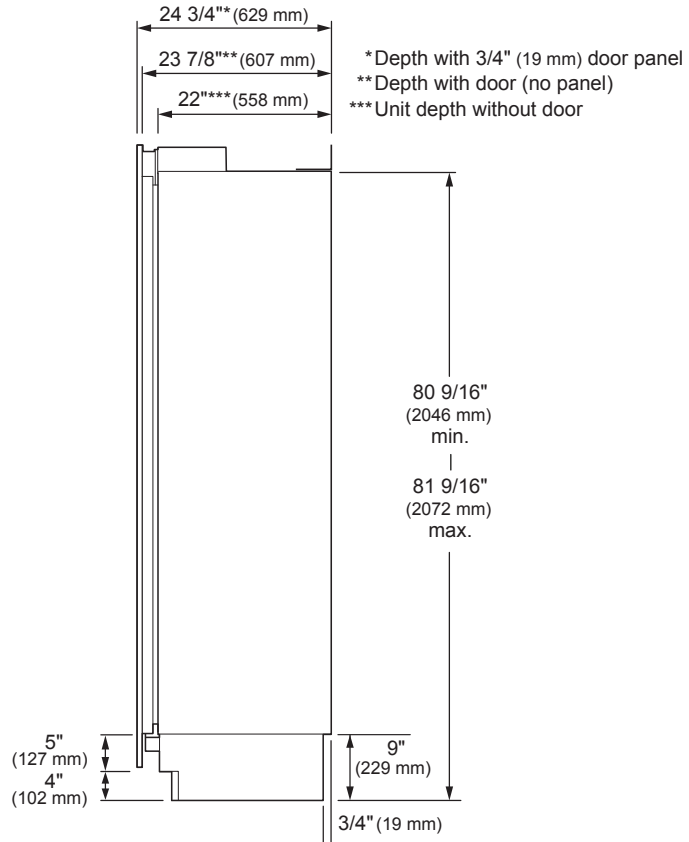

TOP VIEW

DOOR OPEN 90°

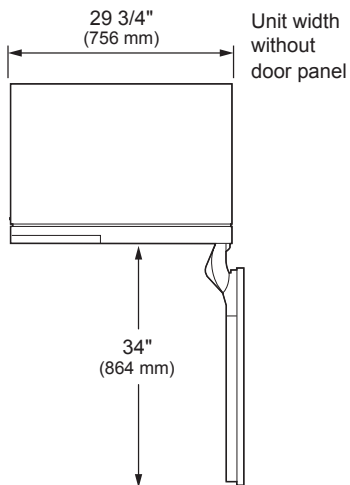

DOOR OPEN 115°

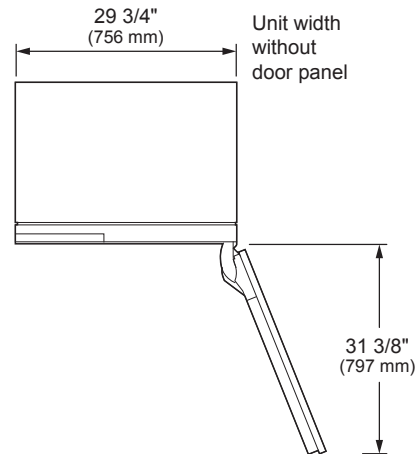

SKSCF3001P

30-INCH INTEGRATED COLUMN FREEZER

CUSTOM PANEL DIMENSIONS – FLUSH INSTALLATION

DUAL 18-INCH AND 30-INCH INTEGRATED COLUMNS

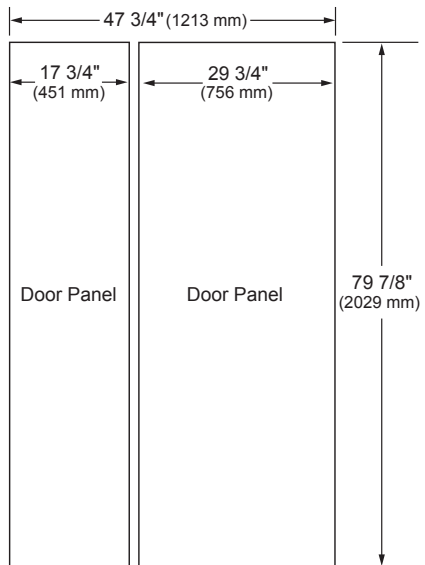

DUAL 24-INCH AND 30-INCH INTEGRATED COLUMNS

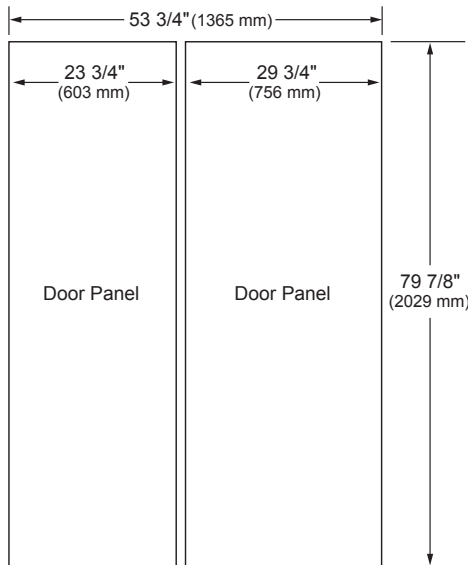

Notes

These units are designed to be customized with decorative panels. Field-installed custom door panels or an optional Stainless Steel Panel Kit is required.

For Custom Panels: Use templates provided with units to pre-drill holes for mounting panel brackets (provided with unit). Adjustment screws and instructions also provided with units.

Maximum Total Door Panel Weights:
30-Inch Integrated Column – 64 lbs.
24-Inch Integrated Column – 53 lbs.
18-Inch Integrated Column – 44 lbs.

Design Tips

4" (102 mm) will be visible on the interior sides of the furniture return. It is recommended that both sides of each cutout panel be finished to match the cabinet exterior.

If using custom panels, a custom toe kick is required. The bottom of case is unfinished.

Door Handles: Handles are not included with the units. Custom handles are required for installation. Brushed Aluminum Handles are available as an optional accessory.

DUAL 30-INCH AND 30-INCH INTEGRATED COLUMNS

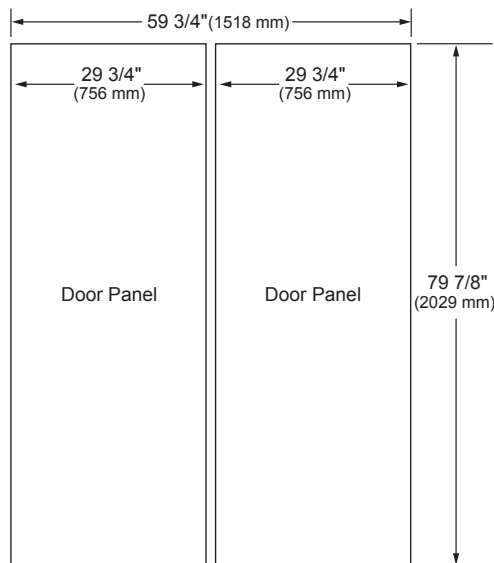

SKSCF3001P

30-INCH INTEGRATED COLUMN FREEZER

OPTIONAL ACCESSORIES – FLUSH OR PROUD INSTALLATION

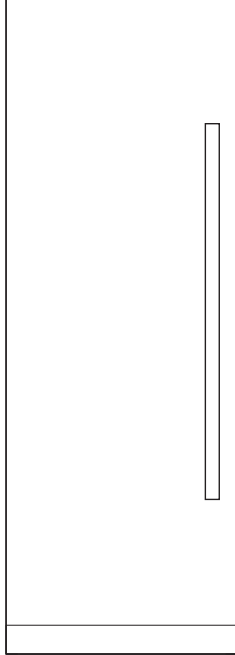

SKSPK305CS – Stainless Steel Panel Kit for 30-inch Integrated Column Refrigerator

This unit can be installed with an optional Stainless Steel Panel Kit. Kit includes one door panel, one toe kick and one handle. This kit is reversible and can be used in both Right Hand and Left Hand door swing installations.

SKSFK800CS – Frame Kit

This unit can be installed in a 24" (610 mm) deep cutout with an optional frame kit. This kit includes two 80" (2032 mm) brushed aluminum side trim pieces. Each trim piece is 5" (127 mm) deep with a 1/8" (3 mm) front face.

Handles for Use With Custom Panels

SKSHK310HS – 31 11/16" (805 mm) Medium Handle – Brushed Aluminum

SKSHK480HS – 48" (1219 mm) Long Handle – Brushed Aluminum

Design Tips

The Stainless Steel Panel Kit may be used in a flush 25" (635 mm) cutout depth installation or in a proud 24" (610 mm) cutout depth installation.

For retrofit/replacement installations where the existing cutout is 24" (610 mm) deep, the optional frame kit is recommended.