

817993

E-Series / Convection Microwave Trim Kit

CONTAINS:

E-Series MWC24

QTY	DESCRIPTION	QTY	DESCRIPTION
1	Frame Assembly	2	Large Glass Trim
6	Screw, 6-18x1" TPG Type A	2	Large Foam
2	Screw, #8-15x1/2" Truss HD	2	Large Foam
1	Top Ductwork	1	Instructions
1	Bottom Ductwork		

INSTALLATION PROCEDURE:

Cabinet Opening Preparations and Installation of Mounting Brackets

1. Locate properly grounded 3-prong receptacle within 4" (102mm) from the right side and 4" (102mm) up from bottom of microwave oven cabinet.

⚠ CAUTION

Install the MWC24 with a 120V, 60Hz, on a dedicated circuit. This outlet must be checked by a qualified electrician to see if it is wired with correct polarity and is correctly grounded. A GFCI outlet is not recommended as this may cause product operation interruptions.

2. Floor of opening should be constructed of plywood strong enough to support weight of oven (about 100lbs/.45kg). Floor should be level for proper operation of oven. Check local building code as it may require that opening be enclosed with sides, ceiling and rear partition. Proper functioning of the oven does not require this enclosure.

Top Duct Installation For MWC24

Step 1:

- A. Lining up feet of microwave with holes in bottom duct assembly, place microwave on assembly (See Figure 1).
- B. Assemble top duct. (See Figure 2).
- C. Remove existing screws, one from upper right and one from left rear of oven (See Figure 3).
- D. Place top duct assembly on microwave and re-insert screws (See Figure 3).

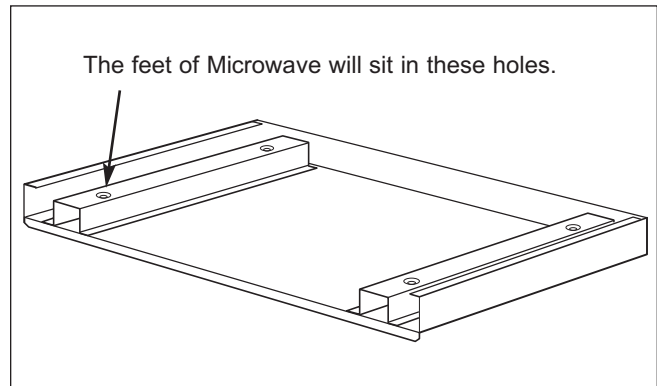

Figure 1. Bottom Duct Assembly

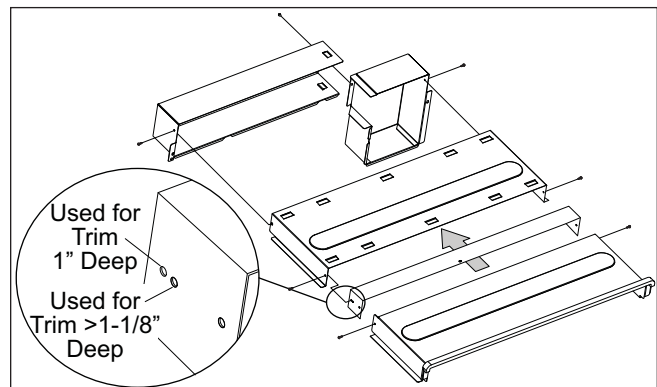

Figure 2. Top Duct Assembly

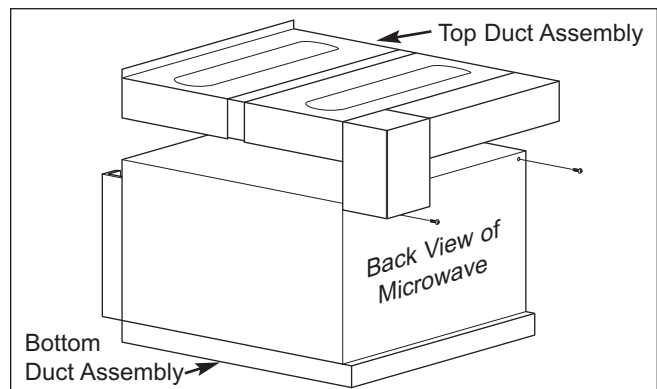

Figure 3. Attaching Top Duct to Microwave

817993

E-Series / Convection Microwave Trim Kit

Step 2 (Refer to Figure 4):

- A. Place oven adjacent to wall or cabinet opening and plug power cord into electrical outlet.
- B. Carefully guide complete assembly between bottom cleats and push assembly back.
NOTE: Avoid pinching power cord between oven and back wall of cabinet opening.
- C. Secure bottom duct assembly using two #8-15x1/2" screws.
- D. Attach frame assembly directly to cabinet opening, using four #6-18x1" wood screws.
NOTE: Always pre-drill a pilot hole before installing screws to avoid damage to cabinet or trim kit hardware.
- E. Adhere decorative trim panels to side brackets, so they are tight to side and bottom of frame assembly (See Figure 5).
NOTE: The pieces of foam tape are to be used if gaps appear between the frame and the microwave perimeter. If gaps are present, remove the trim and adhere the foam tape to the microwave where needed.

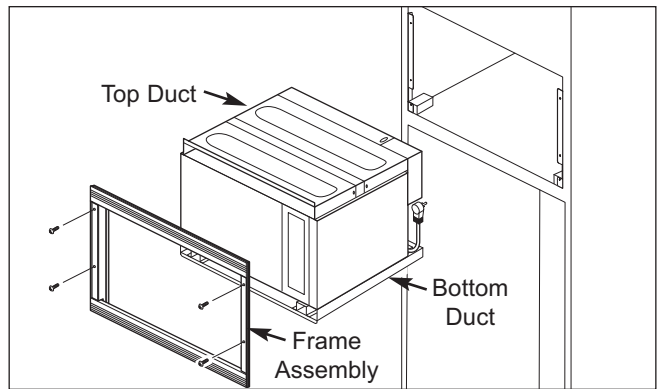

Figure 4. Microwave Install in Cabinet Opening

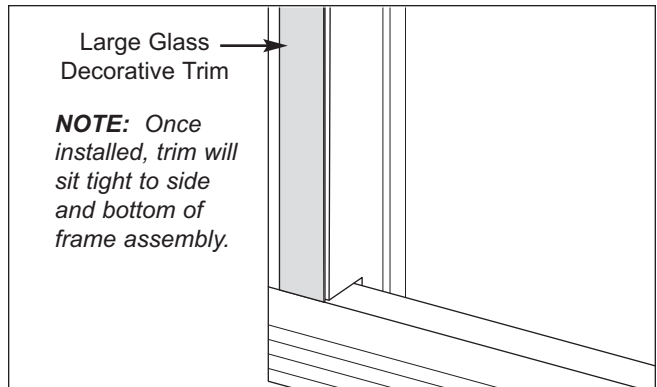

Figure 5. Decorative Trim / Unframed Assembly