



ASSEMBLY INSTRUCTIONS COASTER FINE FURNITURE



Fine Furniture for every stage of life

300843KW (B1-B3) California King Bed

REVISION 0: 01/17/2017
REVISION 1: 08/14/2018
REVISION 2: 08/20/2018
REVISION 3: 08/27/2019
REVISION 4: 12/21/2020

PAGE 1 OF 10

COASTERFURNITURE.COM

ITEM: 300843KW (B1-B3)



ASSEMBLY INSTRUCTIONS

ASSEMBLY TIPS:

1. Remove hardware from box and sort by size.
2. Please check to see that all hardware and parts are present prior to start of assembly.
3. Please follow attached instructions in the same sequence as numbered to assure fast & easy assembly.



WARNING!

1. Don't attempt to repair or modify parts that are broken or defective. Please contact the store immediately.
2. This product is for home use only and not intended for commercial establishments.





ASSEMBLY TIME

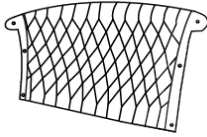
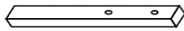

40 MINUTES

PARTS IDENTIFICATION

B1 (BOX 1)

A	HEADBOARD PANEL		1PC
B	HEADBOARD LEG		2PCS
C	HEADBOARD SUPPORT PANEL		1PC

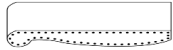
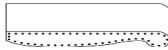
B2 (BOX 2)

D1	LEFT WING		1PCS
D2	RIGHT WING		1PCS
E	WING SUPPORT		2PCS

B3 (BOX 3)

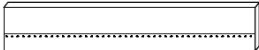
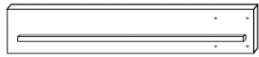
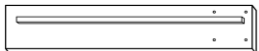
F	FOOTBOARD PANEL		1PC
G1	LEFT BED RAIL		1PC
G2	RIGHT BED RAIL		1PC

NOTE:

Phillips head screw driver is required in the assembly process; however, manufacturer does not provide this item.

ITEM: 300843KW (B1-B3)



ASSEMBLY INSTRUCTIONS

ASSEMBLY TIPS:









1. Remove hardware from box and sort by size.
2. Please check to see that all hardware and parts are present prior to start of assembly.
3. Please follow attached instructions in the same sequence as numbered to assure fast & easy asse



WARNING!

1. Don't attempt to repair or modify parts that are broken or defective. Please contact the store immediately.
2. This product is for home use only and not intended for commercial establishments.

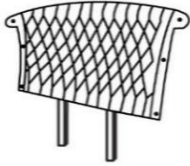
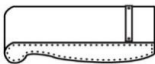
PARTS IDENTIFICATION

H	BED SLAT WITHOUT HOLE		10PCS
I	BED SLAT WITH HOLES		3PCS
J	BED SLAT SUPPORT		6PCS
K	FOOTBOARD LEG		2PCS
L	CENTER RAIL		2PCS
M	CENTER RAIL SUPPORT		2PCS
HB	300843KW (B1) FROM BOX 1 HEADBOARD COMPLETE		1PC
ER 1	300843KW (B2) FROM BOX 2 WING COMPLETE		1PC
ER 2	300843KW (B2) FROM BOX 2 WING COMPLETE		1PC

Phillips head screw driver is required in the assembly process; however, manufacturer does not provide this item.

ITEM: 300843KW (B1-B3)



ASSEMBLY INSTRUCTIONS

ASSEMBLY TIPS:

1. Remove hardware from box and sort by size.
2. Please check to see that all hardware and parts are present prior to start of assembly.
3. Please follow attached instructions in the same sequence as numbered to assure fast & easy assembly.













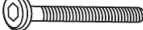

WARNING!

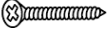
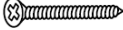
1. Don't attempt to repair or modify parts that are broken or defective. Please contact the store immediately.
2. This product is for home use only and not intended for commercial establishments.

HARDWARE IDENTIFICATION

Z-B3 (BOX 3) - HARDWARE PACK IS LOCATED IN 300843KW (B3)

1	ALLEN WRENCH (Φ6 - BLK)		1PC
2	BOLT 1 (Φ6 X 30mm - RBW)		4PCS
3	BOLT 2 (Φ6 X 45mm - RBW)		12PCS
4	BOLT 3 (Φ6 X 60mm - RBW)		10PCS
5	BOLT 4 (Φ6 X 90mm - RBW)		8PCS
6	SHORT FLAT HEAD SCREW (Φ4 X 16mm - RBW)		8PCS
7	MEDIUM FLAT HEAD SCREW (Φ4 X 32mm - RBW)		28PCS
8	LONG FLAT HEAD SCREW (Φ4 X 45mm - RBW)		4PCS
9	BIG FLAT WASHER (Φ3/8 X 25 X 1 - RBW)		24PCS
10	MEDIUM FLAT WASHER (Φ7 X 19 X 2 - RBW)		24PCS
11	SMALL FLAT WASHER (Φ6 X 13 X 1 - RBW)		4PCS
12	LOCK WASHER (Φ6 - RBW)		24PCS
13	LEVELER (Φ6 X 23mm - RBW)		6PCS

NOTE:

Phillips head screw driver is required in the assembly process; however, manufacturer does not provide this item.

ITEM: **300843KW (B1-B3)**



ASSEMBLY INSTRUCTIONS

STEP 1

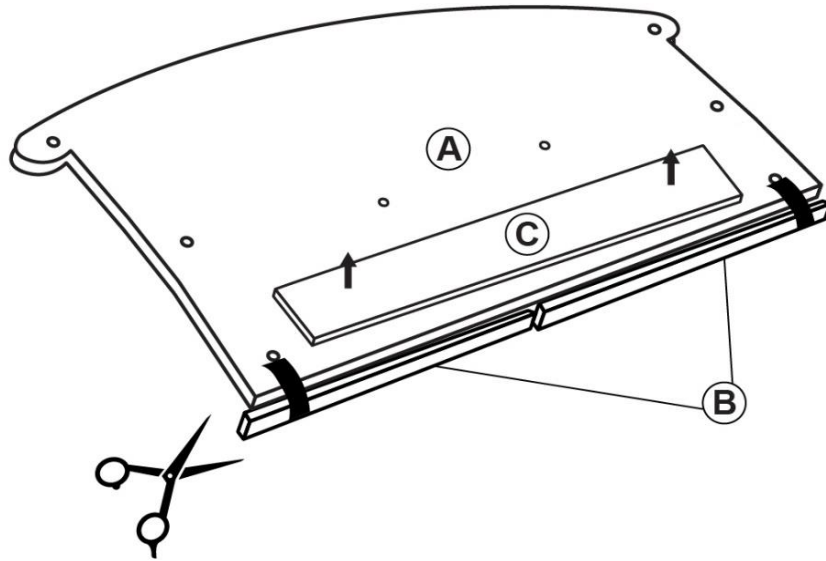

STEP 2

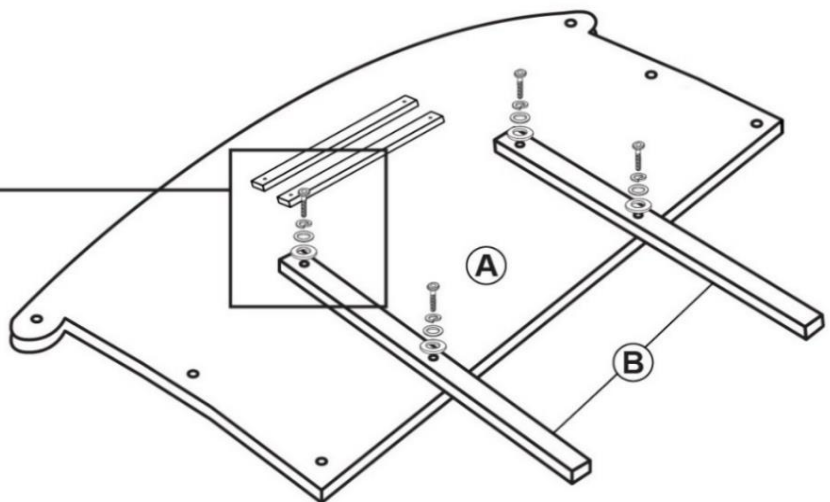
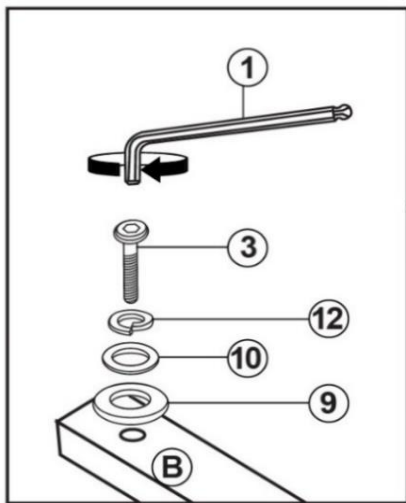

ASSEMBLY INSTRUCTIONS

STEP 3

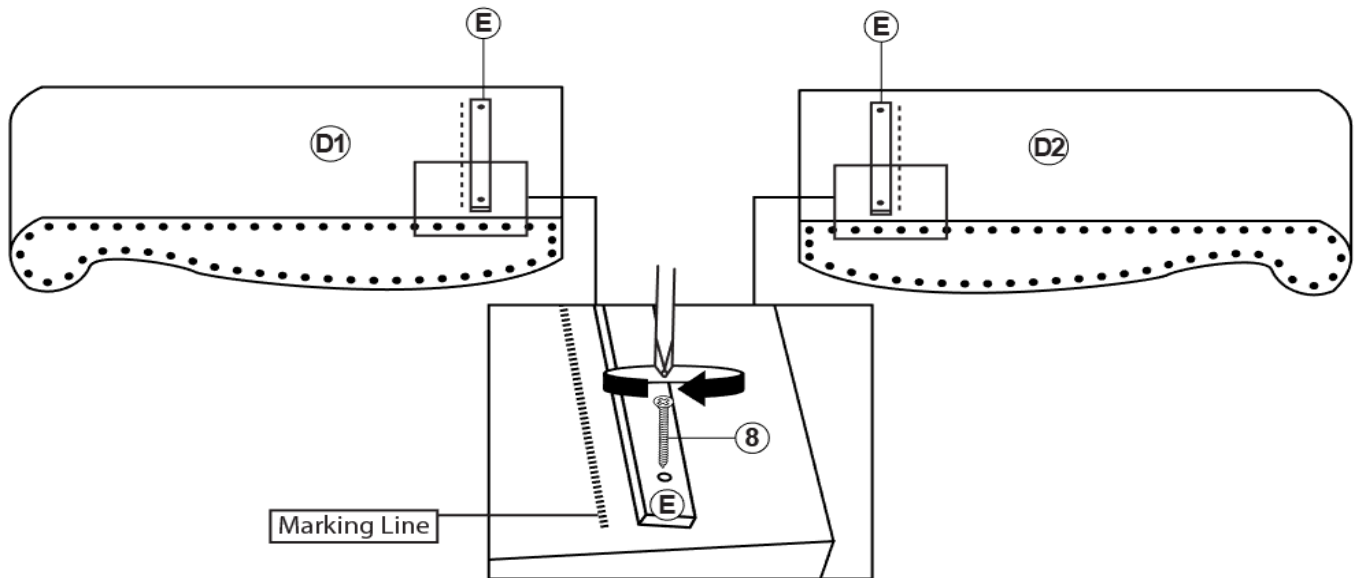

*Assemble wing support at the bottom of the marking line.

STEP 4

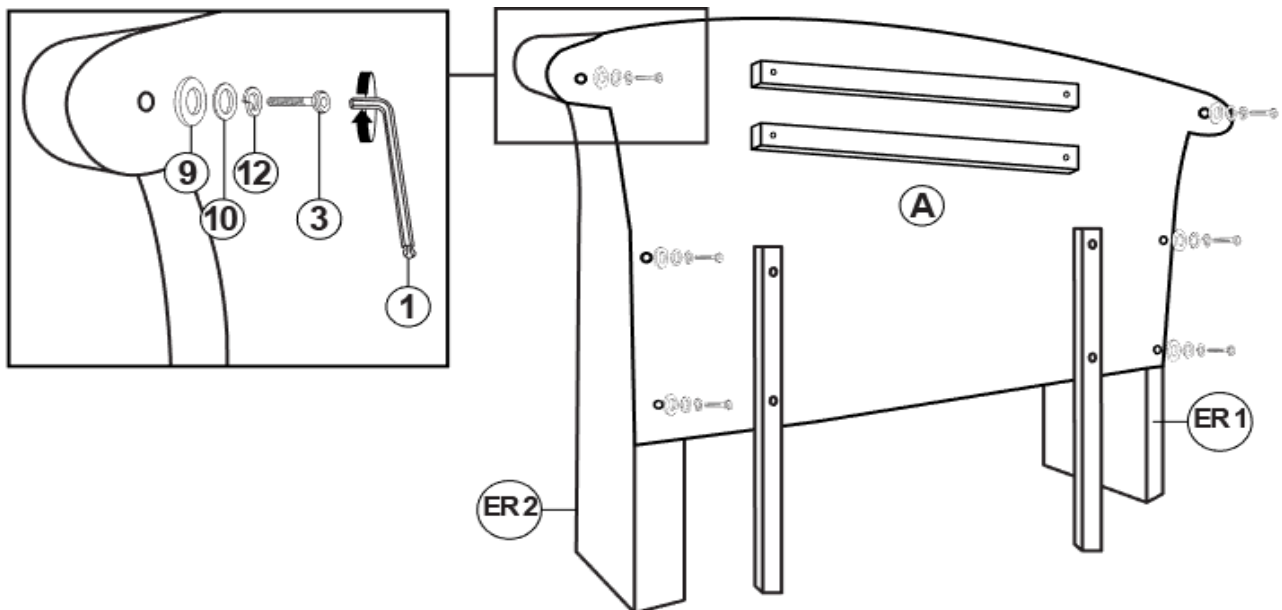

ITEM: 300843KW (B1-B3)

ASSEMBLY INSTRUCTIONS

STEP 5

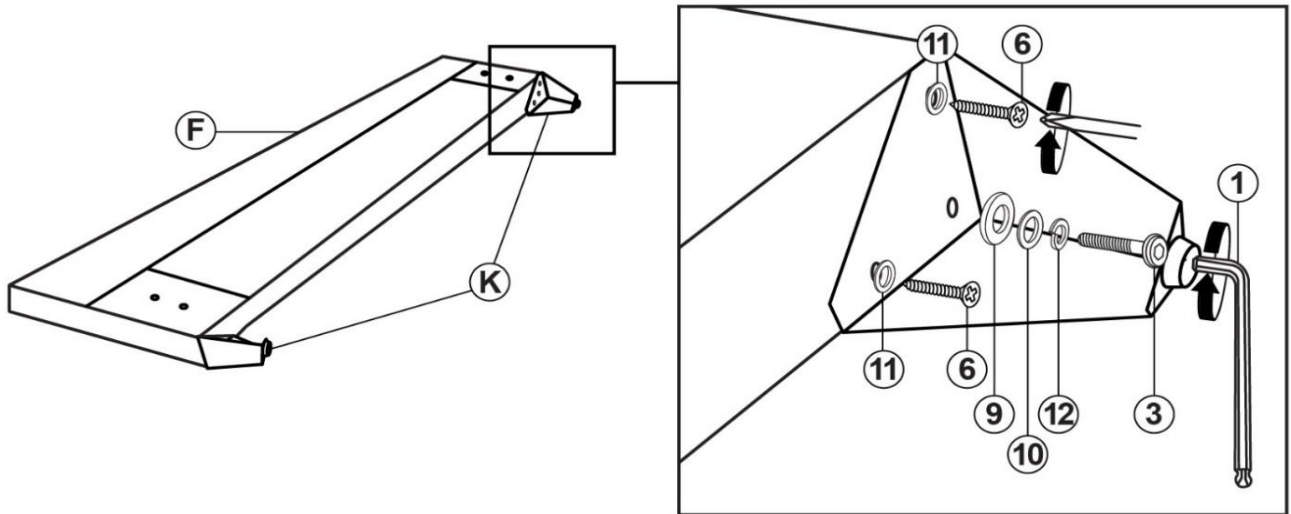

STEP 6

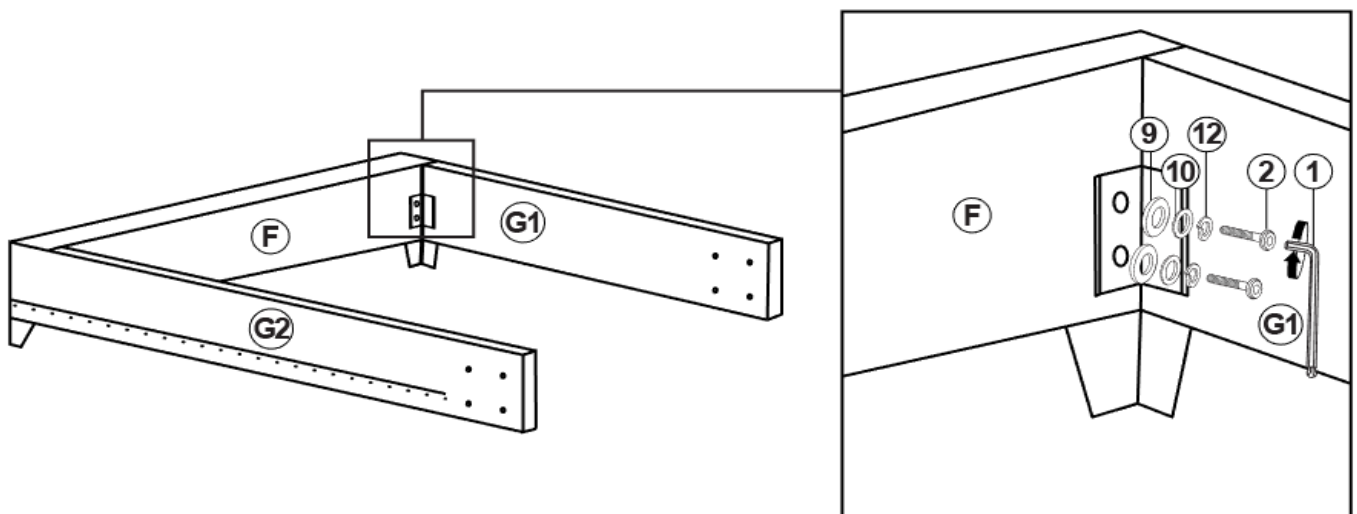

ITEM: **300843KW (B1-B3)**



ASSEMBLY INSTRUCTIONS

STEP 7

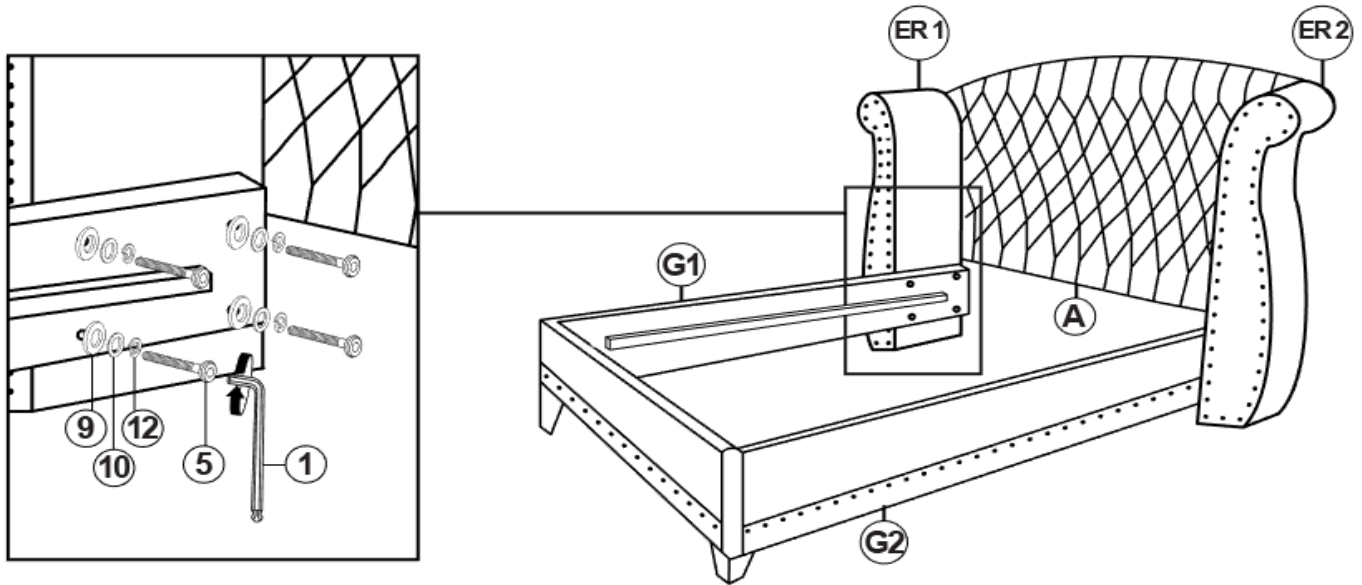

STEP 8

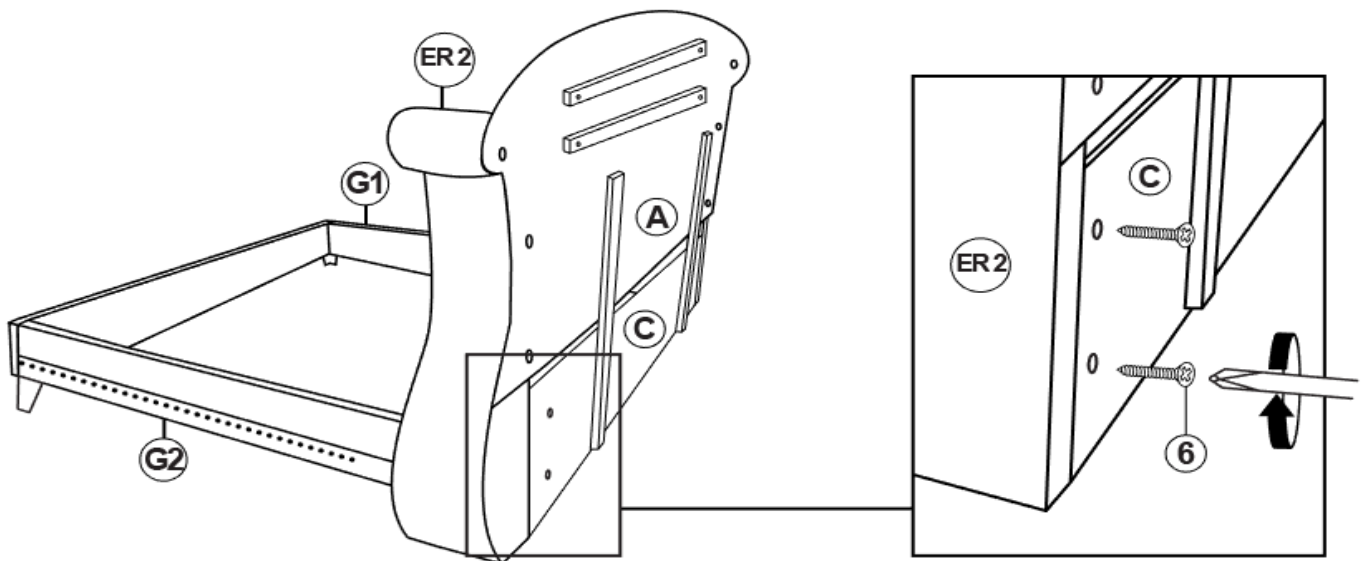

ITEM: 300843KW (B1-B3)

ASSEMBLY INSTRUCTIONS

STEP 9

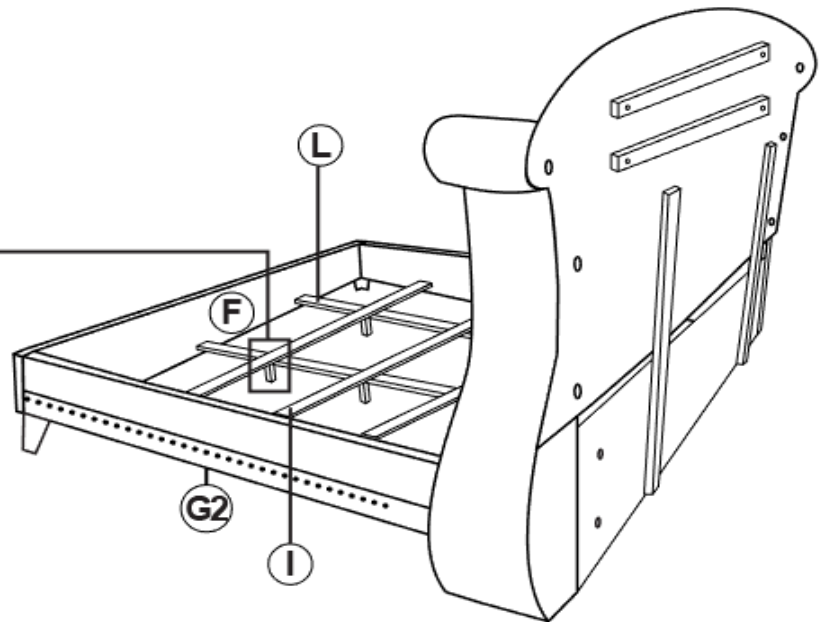
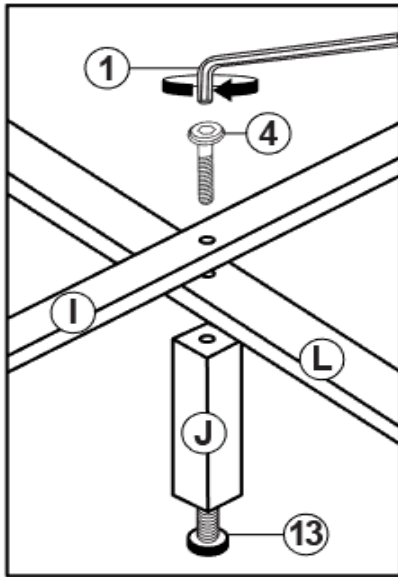

STEP 10

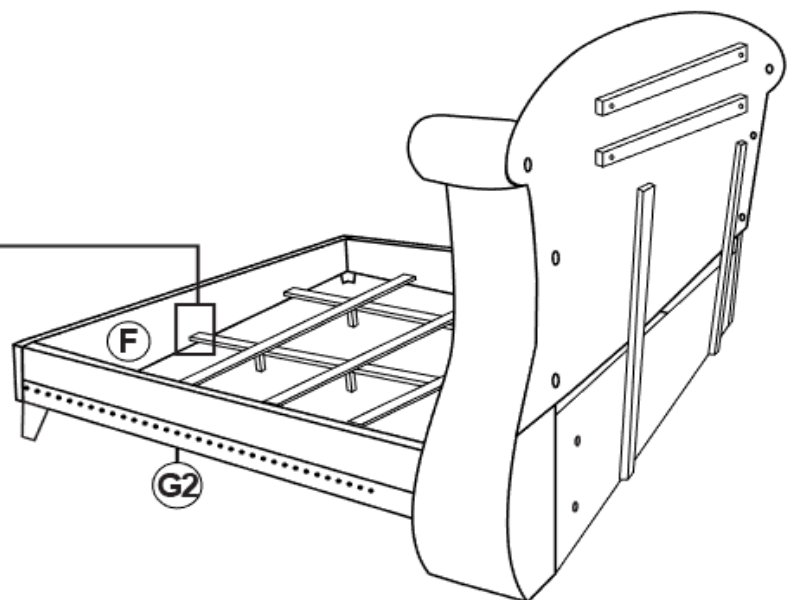
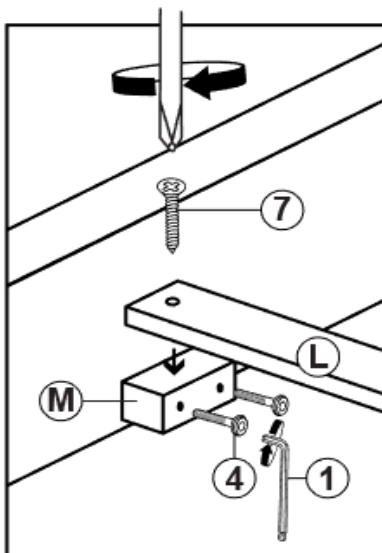

ITEM: **300843KW (B1-B3)**



ASSEMBLY INSTRUCTIONS

STEP 11

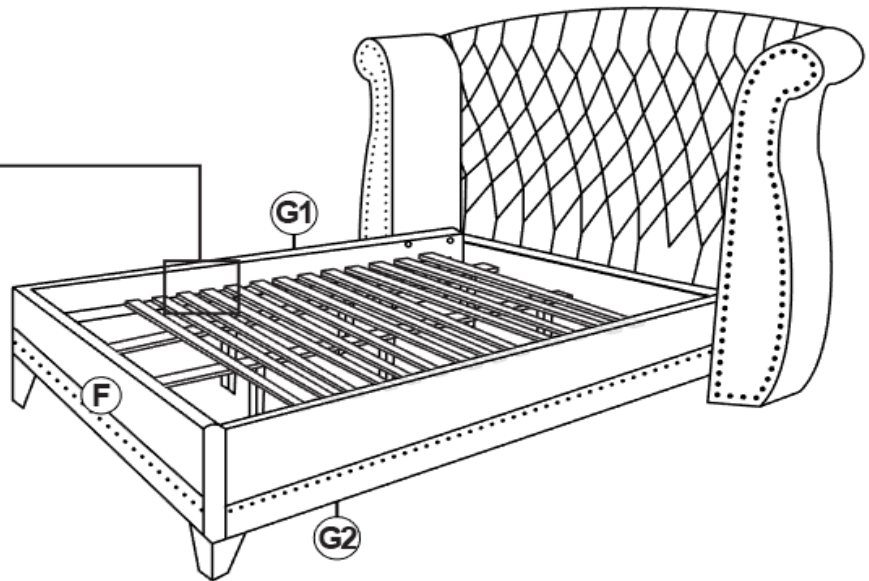
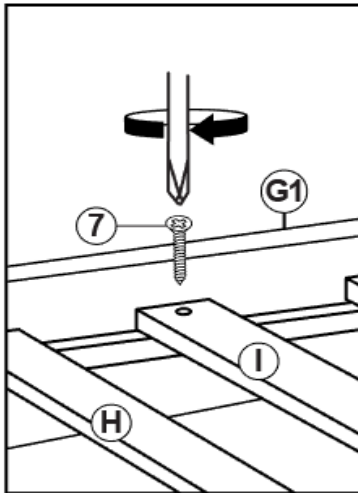

STEP 12
COMPLETE

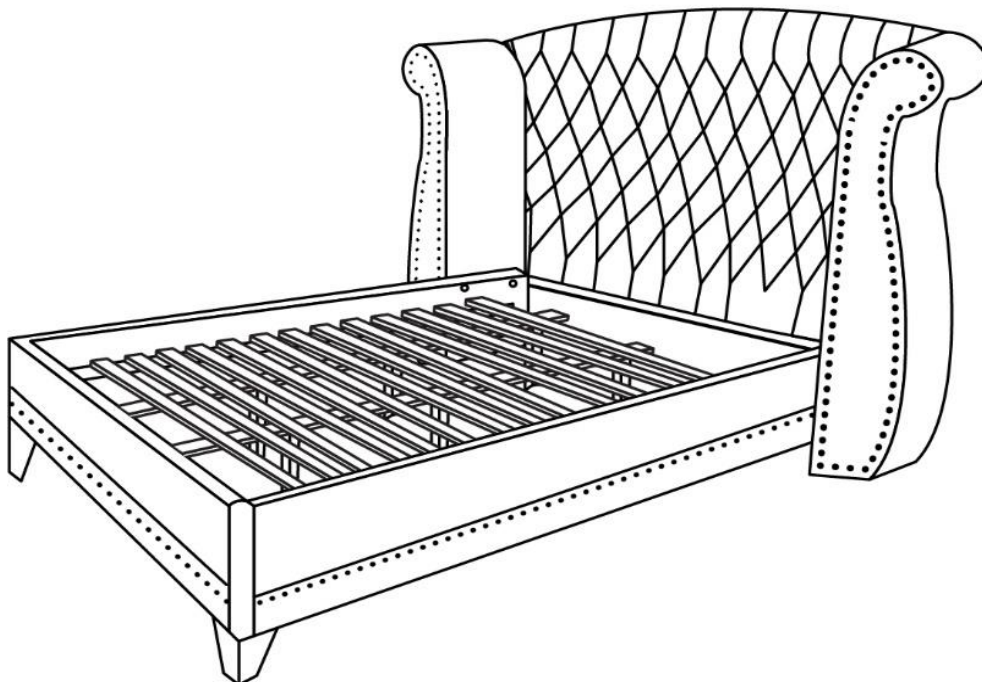

ITEM: 300843KW (B1-B3)

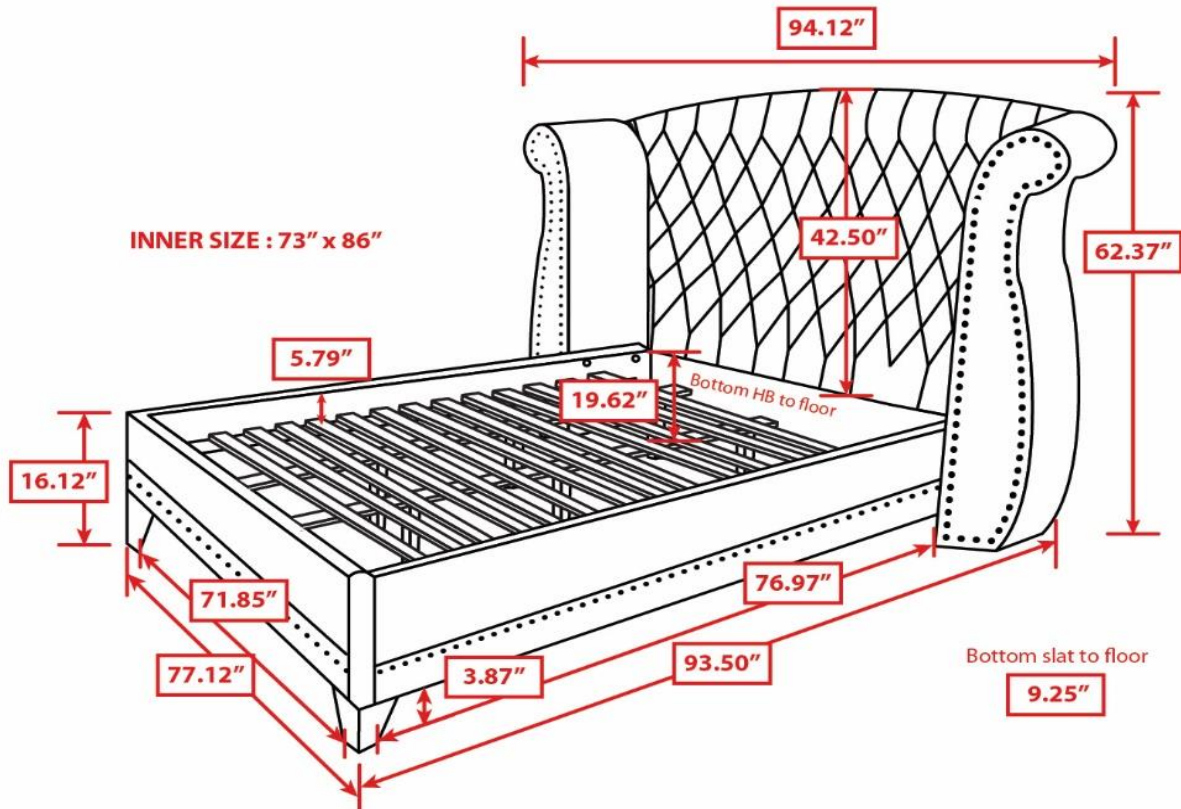

Note : Dimension tolerance $\pm 5\%$