



SPINWAVE® + VAC VACUUM MOP 3764, 3851 SERIES

Important Safety Instructions.....	2
Warranty.....	3
What's in the Box?	3
Assembly and Charging the Battery	4
Attaching the Mop Pads.....	4
Filling the Clean Water Tank.....	5
Controls and Cleaning Tips.....	6
Cleaning Your Floors.....	7
Emptying the Dirt Tank.....	8
After-Cleaning Care.....	9
Troubleshooting.....	10

Product Overview

- | | |
|---------------------------------|------------------------------------|
| 1. Handle | 6. Clean Water Tank Release Button |
| 2. Power & Mode Buttons | 7. Clean Water Tank |
| 3. Charging Port | 8. Vacuum Air Path |
| 4. Dry Dirt Tank | 9. Mop Pads |
| 5. Dry Dirt Tank Release Button | |

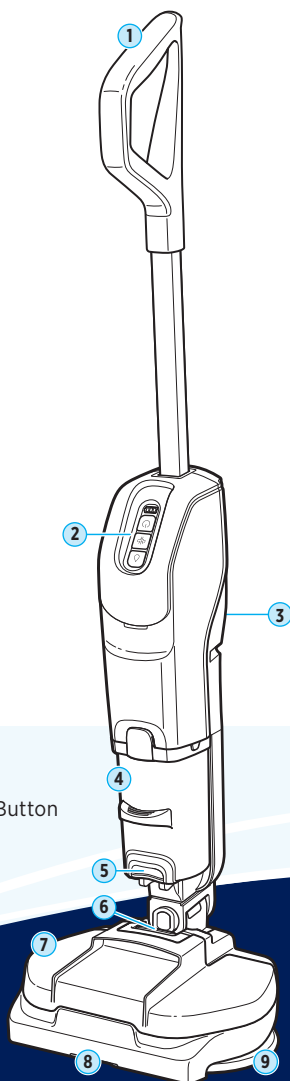

Meet your new BISSELL® product!

Go to support.BISSELL.com for a walkthrough of your new purchase, including videos, tips, support, and more. Want to get started right away? This guide has all the information you need to set up your new product. Let's take a look...

IMPORTANT SAFETY INSTRUCTIONS



READ ALL INSTRUCTIONS BEFORE USING YOUR APPLIANCE.

When using an electrical appliance, basic precautions should be observed, including the following:



WARNING

TO REDUCE THE RISK OF FIRE, ELECTRIC SHOCK OR INJURY:

- Use indoors only.
- Do not immerse. Use only on surfaces moistened by cleaning process.
- Use only cleaning products intended for use with this appliance to prevent internal component damage. See the Cleaning Formulas section of this guide.
- Children should be supervised to ensure that they do not play with the appliance.
- Do not allow to be used as a toy. Close attention is necessary when used by or near children.
- Do not use for any purpose other than described in this user guide. Use only manufacturer's recommended attachments.
- Do not charge with damaged charger or plug. If appliance is not working as it should, has been dropped, damaged, left outdoors or dropped into water, have it repaired by a qualified technician.
- Do not pull or carry charger by cord, use cord as a handle, close door on cord, or pull cord around sharp edges or corners. Do not run appliance over cord. Keep cord, docking station or Charger away from heated surfaces.
- Do not unplug charger by pulling on cord. To unplug, grasp the charger plug, not the cord.
- Do not handle charger, charger plug, or appliance with wet hands.
- Do not put any object into openings. Do not use with any opening blocked; keep openings free of dust, lint, hair, and anything that may reduce air flow.
- Keep hair, loose clothing, fingers, and all parts of body away from openings and moving parts.
- Mop pads may start unexpectedly. Unplug before cleaning or servicing.
- Turn OFF all controls before plugging or unplugging charger.
- Use extra care when cleaning on stairs.
- Do not use to pick up flammable or combustible materials (lighter fluid, gasoline, kerosene, etc.) or use in areas where they may be present.
- Do not pick up anything that is burning or smoking, such as cigarettes, matches, or hot ashes.
- Do not use without filters in place.
- Risk of injury from moving parts. Brush may start unexpectedly. Turn OFF before cleaning or servicing.
- Turn OFF all controls, including the power switch, and disconnect charger from electrical outlet before making any adjustments, performing maintenance, troubleshooting, changing accessories, or storing appliance. Such preventative safety measures reduce the risk of starting the appliance accidentally.
- Recharge appliance only with the charger specified by the manufacturer. A charger that is suitable for one type of battery pack may create a risk of fire when used with another battery pack.
- Use only with charger: SUNSTRONG INTERNATIONAL INDUSTRIAL LTD., MODEL SSC-297100US.
- Battery pack, charging port on the appliance and charger output are not to be shortcircuited.
- Under abusive conditions, liquid may be ejected from the battery; avoid contact. If contact accidentally occurs, flush with water. If liquid contacts eyes additionally seek medical help. Liquid ejected from the battery may cause irritation or burns.
- Do not use appliance that is damaged or modified. Damaged or modified batteries may exhibit unpredictable behavior resulting in fire, explosion or risk of injury.
- Do not expose battery pack or appliance to fire or excessive temperature. Exposure to fire or temperature above 130°C/265°F may cause explosion.
- Follow all charging instructions and do not charge the appliance outside of the temperature range specified in the instructions. Charging improperly or at temperatures outside of the specified range may damage the battery and increase the risk of fire.
- Have servicing performed by a qualified repair person using only identical replacement parts. This will ensure that the safety of the product is maintained.
- Do not modify or attempt to repair the appliance except as indicated in the instructions for use or care.
- Unplug charger from electrical socket when not in use, before cleaning, maintaining or servicing the appliance.
- Keep the temperature range of between 4-40°C/40-104°F when charging battery, storing unit or during use.
- Do not charge the machine outdoors.
- Do not turn your appliance ON until you are familiar with all instructions and operating procedures.
- This appliance contains batteries that are non-replaceable.
- Do not incinerate the appliance even if it is severely damaged. The batteries can explode in a fire.
- The battery must be removed from the appliance before it is scrapped.
- Keep appliance on a level surface.
- Do not carry the appliance while it is in use.
- Do not use appliance in an enclosed space filled with vapors given off by oil-based paint, paint thinner, some moth-proofing substances, flammable dust, or other explosive or toxic vapors.
- Do not use to pick up toxic material (chlorine bleach, ammonia, drain cleaner, etc.).
- Do not pick up hard or sharp objects such as glass, nails, screws, coins, etc.
- Plastic film can be dangerous. To avoid danger of suffocation, keep away from children.

SAVE THESE INSTRUCTIONS

THIS MODEL IS FOR HOUSEHOLD USE ONLY.

COMMERCIAL USE OF THIS UNIT VOIDS THE MANUFACTURER'S WARRANTY.

IMPORTANT INFORMATION

- Keep appliance on a level surface.
- If your appliance has a motorized brush roll, do not leave machine running in the same spot without the handle fully upright.
- Do not store where freezing may occur.

WARNING

This product contains Lithium-Ion rechargeable batteries. DO NOT mix Lithium-Ion batteries with general household waste. According to Federal and State regulations, removal and proper disposal of Lithium-Ion batteries is required. For specific battery disposal instructions please contact Call2Recycle at 877-723-1297 or visit www.call2recycle.org. For full instructions on battery removal for recycling visit support.BISSELL.com.



FCC Part 15 NOTE: This equipment has been tested and found to comply with the limits for a Class B digital device, pursuant to Part 15 of the Federal Communications Commission (FCC) rules. These limits are designed to provide reasonable protection against harmful interference in a residential installation. This equipment generates, uses and can radiate radio frequency energy and, if not installed and used in accordance with the instructions, may cause harmful interference to radio communications. However, there is no guarantee that interference will not occur in a particular installation. If this equipment does cause harmful interference to radio or television reception, which can be determined by turning the equipment OFF and ON, the user is encouraged to try to correct the interference by one or more of the following measures: (1) Reorient or relocate the receiving antenna. (2) Increase the separation between the equipment and receiver. (3) Connect the equipment into an outlet on a circuit different from that to which the receiver is connected. (4) Consult the dealer or an experienced radio/TV technician for help. This device complies with Part 15 of the FCC rules. Operation is subject to the following two conditions: (1) this device may not cause harmful interference, and (2) this device must accept any interference received, including interference that may cause undesired operation. CAUTION: Any changes or modifications to this unit not expressly approved by the party responsible for compliance could void the user's authority to operate the equipment.





Warranty

Limited 2-year warranty, may vary by state. Visit support.BISSELL.com or call 1-800-237-7691 for complete warranty information.

NOTICE Disconnecting the battery will destroy the appliance and invalidate the warranty.

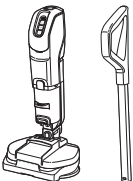
What's in the Box?

Standard accessories may vary by model. To identify what should be included with your purchase, please refer to the "Carton Contents" list located on the carton top flap.

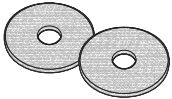
				
Body & Handle	Storage Tray	Trial Formula	Charger	Mop Pads (quantity and style may vary by model)

Assembly and Charging the Battery



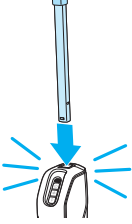
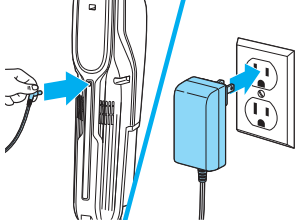
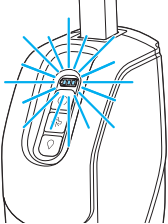

Important Charging Information:

- Plug in the machine immediately upon receiving. For maximum run time (up to 70 minutes in Wet Mop-Only mode) charge for 3 hours before use.
- If planning to store for over 6 months, ensure battery is fully charged before storage.

		
1. Insert handle into body until it clicks into place.	2. Before charging, ensure machine is OFF. Plug charging adapter into machine and then into a wall outlet. Battery status indicator lights will illuminate.	3. Battery indicator lights will blink during charging and illuminate fully at 70% charge. When fully charged, lights will turn off.

Battery Power Indicator

Your machine has an LED light display that will turn on when power button is pushed to show battery life status.

				
100% to 67%	66% to 33%	32% to 10%	< 10%	0%

Attaching the Mop Pads

Note: Your machine may come with mop pads attached.

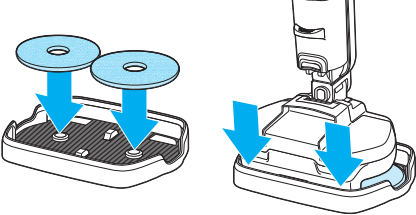
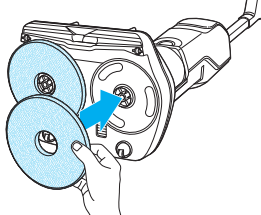
	
Option 1: With Tray Place mop pads on tray, aligning center opening of pad on raised parts of tray. Tilt machine so front of foot aligns to tray. Set machine down, tray and pads should align and attach.	Option 2: Without Tray With machine OFF, remove clean tank and flip machine so you can see under the foot. Align pads to circles on foot.

⚠ WARNING To reduce the risk of fire and electric shock due to internal component damage, use only BISSELL cleaning formula intended for use with this machine.

Filling the Clean Water Tank

Find more formulas at [BISSELL.com](https://www.bissell.com).

This machine is compatible with BISSELL® formulas made for hard surfaces. Always use genuine BISSELL formulas in your machine. Other formulas may harm the machine.

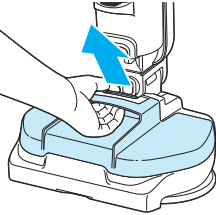
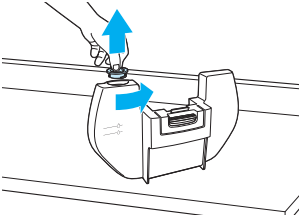
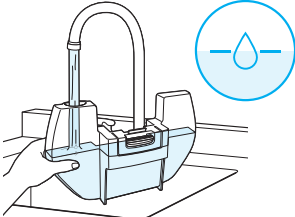
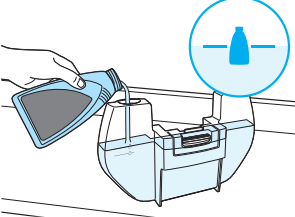
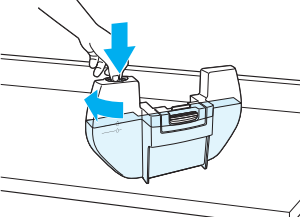
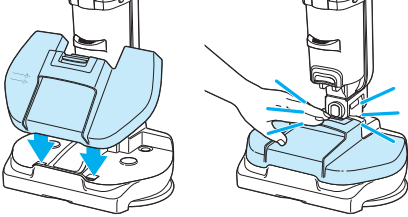
		
<p>1. Choose your formula.*</p>	<p>2. Remove tank from foot using center grip. Tank can be set on a flat surface if needed.</p>	<p>3. Twist cap to remove.</p>
		
<p>4. Add warm water (140°F / 60°C max) to water line.</p>	<p>5. Add BISSELL formula to formula line.</p>	<p>6. Close cap.</p>
		
<p>7. Reinstall tank to machine. It will click into place.</p>		

*Compatible BISSELL formulas include: Multi-Surface, Wood Floor, Hard Floor Sanitize, Simply Multi-Surface, Multi-Surface Pet Lemon Eucalyptus

Controls and Cleaning Tips

Controls



Power On/Off

Machine defaults to dry vacuum ON and wet mop OFF.

Machine will remain in last cleaning mode used if turned back on within 5 minutes.



Dry Vacuum On/Off

RUN TIME: 20 MINS

Note: Do not use for wet spills. If wet debris or water gets into dry dirt tank, reference pages 8–9 for steps on how to clean it out.

White LED indicates vacuum is ON.

Great for light debris pick-up and quick touch-ups, such as:

- Baking soda
- Dirt
- Pet hair
- Cat litter
- Dry crumbs
- *and more!*
- Confetti
- Pet food



Wet Mop On/Off

RUN TIME: 70 MINS

Blue LED indicates wet mop is ON.

Scrub, mop, and refresh hard floors.

With wet mop ON, recline machine. Mop pads will start spinning and fluid will flow through center opening of pads to floor. See next page for more.



Dry Vacuum + Wet Mop at the Same Time

RUN TIME: 20 MINS

Turn both modes on for fast and easy 2-in-1 cleaning.

Cleaning Tips

This product is meant for sealed hard surfaces. Do NOT use this product on area rugs or carpet.

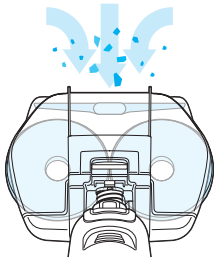

Vacuuming Dry Debris

For optimal performance, use clean, dry pads to capture debris with fewer passes. Aim machine front and center for best suction.

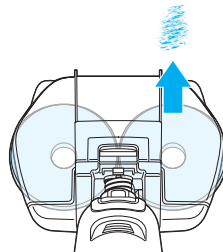

Mopping Tough Messes

For difficult, stuck-on messes, aim center of mop pad on stain. Fluid comes through center of each mop pad.

Seeing a dry path on the floor where the pads touch? Slow down for even cleaning. Aim for 8 inches per second. Your foot may be a helpful reference as you move the machine along.

Cleaning Your Floors

IMPORTANT: Ensure heavy debris, puddles and/or heavy wet messes are removed from floor before starting. The vacuum is for cleaning dry debris; do not use the vacuum mode for picking up wet spills. If wet debris or water gets into dirty tank, reference pages 8-9 for steps on how to clean it out.

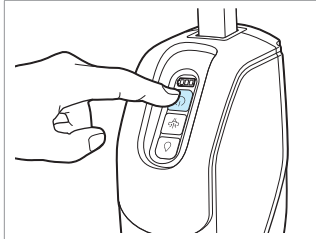

1. Press power button to turn machine ON. Machine starts with dry vacuum ON.

Note: Machine will remain in last cleaning mode used if turned back on within 5 minutes.

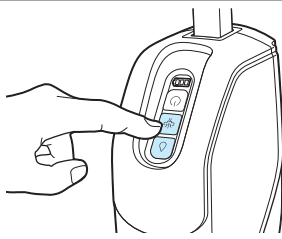

2. Select mode: dry vacuum, wet mop, or both. Each mode has a light indicating it is ON. See page 6 for cleaning modes.

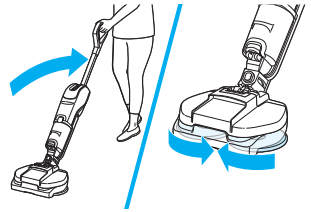

3. Recline machine to start spinning mop pads.

In wet mop mode, start by moving the device back and forth to prime (about 30 seconds).

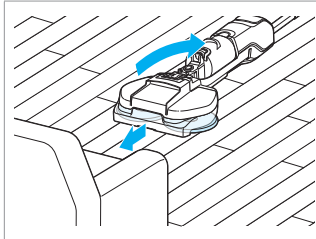

4. Your machine can recline to lay flat to help reach under low clearances.

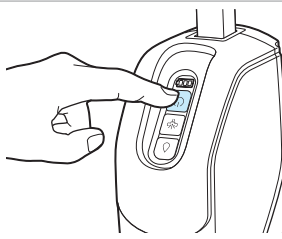

5. Press power button to turn OFF. **Note:** Machine will remain in last cleaning mode used if turned back on within 5 minutes.

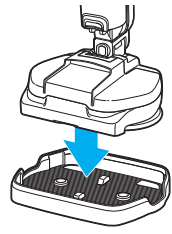

6. When finished cleaning, place machine in storage tray.

Using Swivel for Edge Cleaning



Edge Vacuuming: Swivel the device to a 90° angle and glide effortlessly along the edge.



Edge Mopping: Mop pads are designed to reach right up to the edge, ensuring thorough cleaning against floor trim.

Using Hard Floor Sanitize Formula

Please read "DIRECTIONS FOR USE" on Hard Floor Sanitize label. Use on hard nonporous floors only.

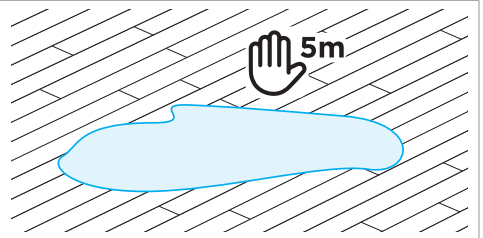
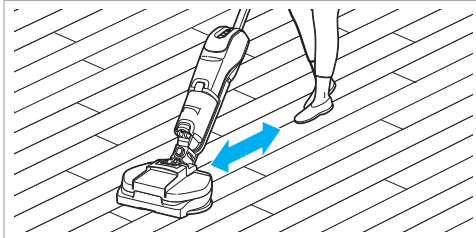

1. Follow cleaning instructions on previous page to remove visible soils.

To Sanitize: Turn dry vacuum OFF and wet mop ON.

2. With wet mop ON, clean floors keeping the device in motion to spread the solution to the floor. Continue doing so to allow the floor to remain wet for 5 min. Allow floors to air dry. Do not use the vacuum during this time.

Emptying the Dirt Tank

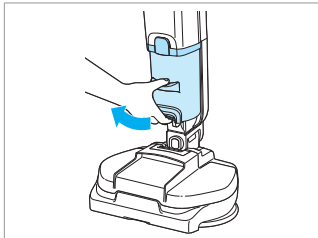

1. Press button at bottom of tank to release. Rotate up and pull tank out to remove.

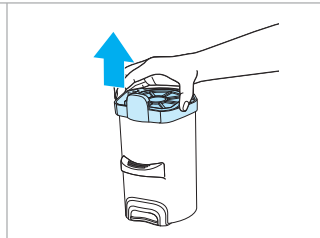

2. Pull lid up to remove.

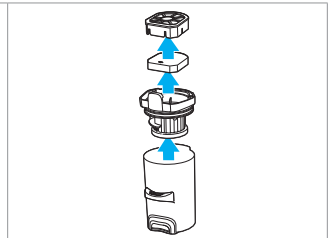

3. Separate filter by pulling blue cage off.

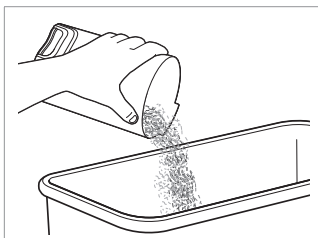

4. Empty tank. If contents appear wet, see next page for cleaning instructions.

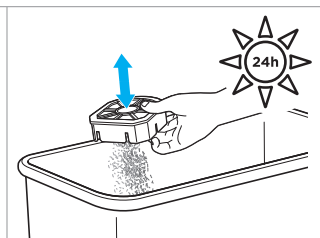

5. Separate filter from tank and tap on side of trash bin to remove dust and debris. If filter feels wet or damp, rinse and allow to **dry completely** before reinstalling.

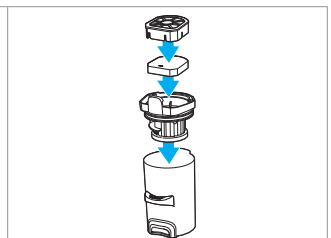

6. Reassemble tank.

CONTINUED ON NEXT PAGE ➔



Emptying the Dirt Tank (continued)

Wet Debris Clean Out

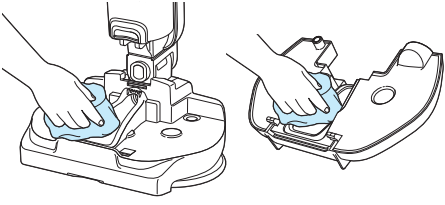
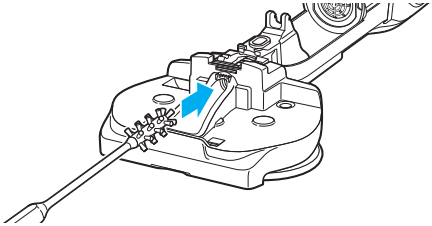
If water is picked up by the vacuum and the dry dirt tank has wet debris, ensure your machine is cleaned out completely.

	
<p>1. Remove clean tank and clean out the vacuum air path.</p>	<p>2. Recline machine for easy access and use a small bottle brush to clear the hose-like path inside the machine.</p>

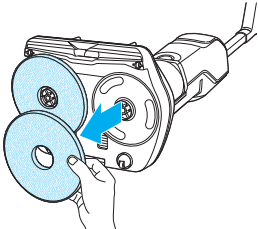
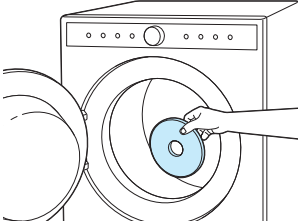
After-Cleaning Care

		
<p>1. Pull mop pads to remove.</p>	<p>2. Mop pads may be machine* or hand washed. <small>*Machine wash warm. Use only liquid detergents. Do not use bleach or fabric softener. Tumble dry on low. Do not iron or dry clean.</small></p>	<p>3. Let mop pads dry completely before reattaching.</p>

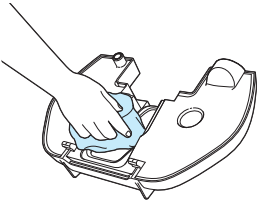
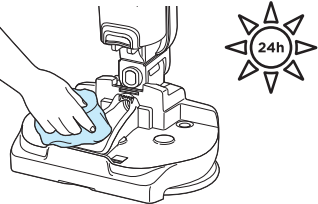
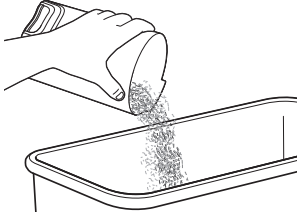
		
<p>4. Use a damp cloth to clean suction path on machine under clean tank and on the foot. Allow to dry completely before reinstalling tank.</p>		<p>5. Empty tank. If contents seem wet, follow prior steps to remove all wet debris.</p>

CONTINUED ON NEXT PAGE ➔

After-Cleaning Care (continued)

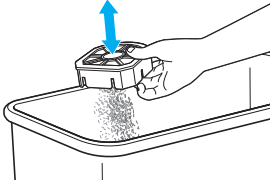
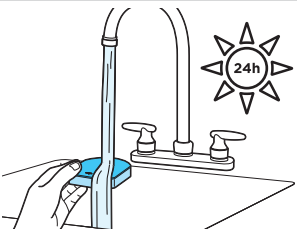
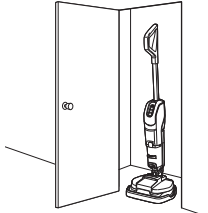
		
<p>6. Separate filter from tank and tap on side of trash bin to remove dust and debris.</p>	<p>7. Occasionally wash filter to maintain vacuum performance. Rinse and allow to dry completely before reinstalling.</p>	<p>8. Store machine in a protected, dry area. Since this product uses water, it must not be stored where there is danger of freezing. Freezing will damage internal components and may void the warranty. If planning to store for over 6 months, ensure battery is fully charged before storage.</p>

Note: Any other maintenance or servicing not included in this manual should be performed by an authorized service representative.

Troubleshooting

Problem	Possible Cause	Remedies
Machine will not turn on	Battery is not charged.	Charge machine with provided charger. If machine charges for 3 full hours and product still doesn't turn on, contact BISSELL Consumer Care.
Mop pads are not spinning	Machine is upright.	Recline machine.
Mop pads are wobbling	Mop pads are not installed properly.	Turn Power OFF. Turn machine upside down to see pad installation. Ensure pads are aligned to center circles on foot and secured tightly.
Fluid is not coming out of machine	Clean water tank is empty.	Refill clean water tank with more warm water and cleaning formula.
	Clean water tank is not seated properly.	Reinstall clean water tank. See instructions on page 5.
	Machine is upright.	Recline machine.
	Spray tips are clogged.	Locate spray tip opening (yellow port) under mop pad driver. Remove debris that may be blocking opening.
Machine is leaking	Cap of clean water tank is not closed properly.	Remove clean water tank and reinstall cap.
	Clean water tank is not seated properly.	Reinstall clean water tank. See instructions on page 5.

CONTINUED ON NEXT PAGE 

Troubleshooting (continued)

Vacuum does not pick up debris/has no suction	Filter needs to be cleaned or is not installed correctly.	Clean and reinstall filters. See instructions on page 8.
	Front suction nozzle is clogged and needs to be cleared.	Machine is for dry messes only. Clean suction path under clean tank, machine foot (page 9). Empty, dry dirt tank before next use. Wash and dry filter before reusing.
	Debris is too large or spread beyond suction area.	Aim machine front and center to large debris for optimal suction performance.
Wet debris in dry dirt tank or fluid coming out of motor exhaust	Moving device too slowly while cleaning or too many wet passes in one area.	Make sure keep unit moving while wet cleaning. Cleaning one spot for a long period of time could cause moisture to be ingested into dry debris collection tank.
	Ran over large, wet mess.	Machine is for dry messes only. Clean suction path under clean tank, machine foot (page 9). Empty, dry dirt tank before next use. Wash and dry filter before reusing.
All (3) LED lights are flashing	Machine lost communication with battery.	Press power button to turn machine off. Wait 10 seconds and turn machine back on. If lights flash again, contact BISSELL Consumer Care.
Vacuum LED flashing	Vacuum motor error: Vacuum motor went into protective status.	Press power button to turn machine off. Wait 10 seconds and turn machine back on. If lights flash again, contact BISSELL Consumer Care.
Wet Mop LED and vacuum LED lights flashing alternately	Pad error: Pad motor went into protective status.	Shut machine off, wait 10 seconds and turn machine back on. If lights flash again, contact BISSELL Consumer Care.
	Device used on area rug or carpet.	Check pads for hair or other material interfering with proper pad rotation. This product is designed for hard floors. Stop use on area rug and carpet.
Machine unexpectedly turns off.	The battery has gone into a protective status.	Wait 10 minutes then press the power button and the machine should begin functioning again.
Mop light is flashing/blinking.	Water pump error.	Press power button to turn machine off. Wait 10 seconds and turn machine back on. If lights flash again, contact BISSELL Consumer Care.



We're Waggin' Our Tails!

BISSSELL proudly supports BISSSELL Pet Foundation® and its mission to help save homeless pets. When you buy a BISSSELL® product, you help save pets, too. We're proud to design products that help make pet messes, odors and pet homelessness disappear.

Visit [BISSSELLsavespets.com](https://www.bissellsavespets.com) to learn more.

But wait, there's more!

Join us online for a complete guide to your new product, including troubleshooting, product registration, parts, and more.

Go to [support.BISSSELL.com](https://support.bissell.com).



REGISTER



INFO



VIDEOS



PARTS



SUPPORT



©2024 BISSSELL Inc. All rights reserved.
Part Number 1641969 01/24 v16