

JETSON

LX10 Folding Electric Ride-On.

A guide for your ride.

IMPORTANT, RETAIN FOR FUTURE REFERENCE: READ CAREFULLY

MODEL: JLX10-BLK | JLX10-BLU | JLX10-RED

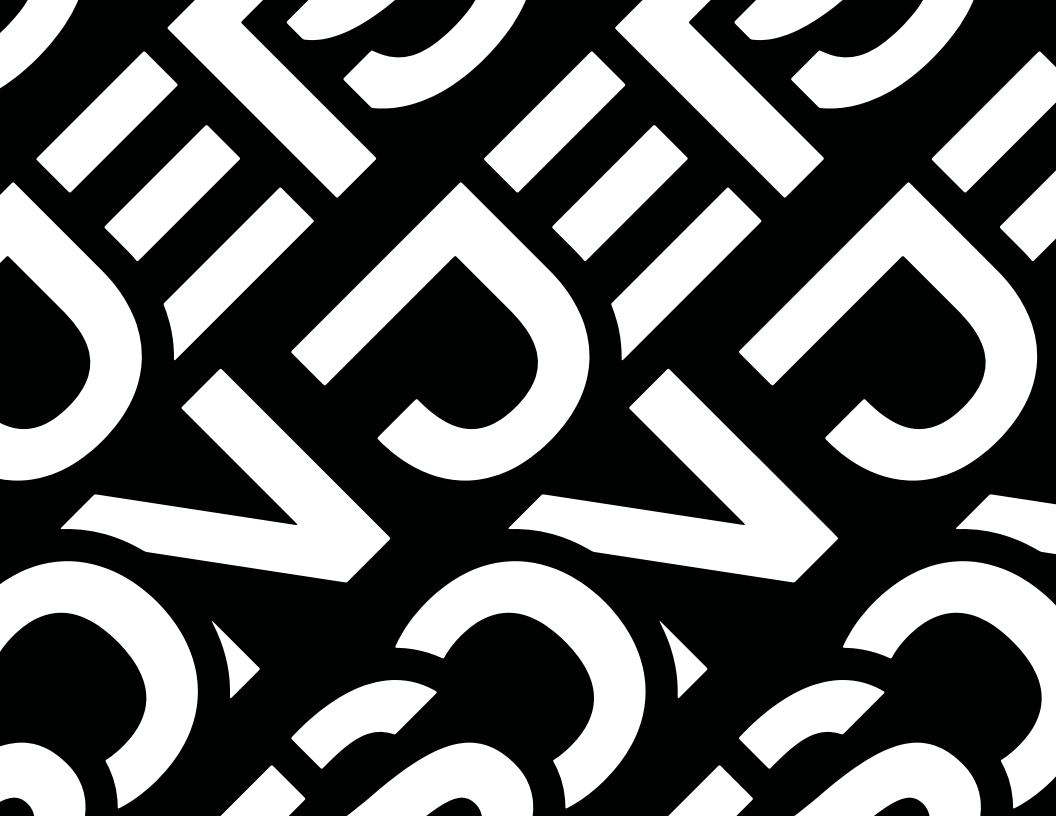

**Remember to be safe and,
most importantly, have fun!**

Table of Contents

Safety Warnings	4
Safe Checklist	7
What's in the Box	8
Specs & Features	11
Attaching the Seat	12
Foot Rest Assembly	15
Attaching the Rear Fender	16
Stay Charged	18
Unfolding the Handlebar	19
Operating the LX10	21
Helmet Safety	22
Riding the LX10	23
Care and Maintenance	24

Safety Warnings

- Before use, please read the user manual and safety warnings carefully, and make sure you understand and accept all the safety instructions. The user will be responsible for any loss or damage caused by improper use.
- Before each cycle of operation, the operator shall perform the preoperation checks specified by the manufacturer: That all guards and pads originally supplied by the manufacturer are in proper place and in serviceable condition; That the braking system is functioning properly; That any and all axle guards, chain guards, or other covers or guards supplied by the manufacturer are in place and in serviceable condition; That tires are in good condition, inflated properly, and have sufficient tread remaining; The area that the product is to be operated should be safe and suitable for safe operation.
- Components shall be maintained and repaired in accordance with the manufacturer's specifications and using only the manufacturer's authorized replacement parts with installation performed by dealers or other skilled persons.
- Warning against recharging non-rechargeable batteries.
- Don't allow hands, feet, hair, body parts, clothing, or similar articles to come in contact with moving parts, wheels, or drive train, while the motor is running.
- This product should not be used by children or persons with reduced physical, sensory or mental capabilities, or lack of experience and knowledge, unless they have been given supervision or instruction (IEC 60335-1/A2:2006).
- Unsupervised children should not play with the product (IEC 60335-1/A2:2006).
- Adult supervision is required.
- The rider should not exceed 260 lb.
- Units shall not be operated to perform racing, stunt riding, or other maneuvers, which may cause loss of control, or may cause uncontrolled operator/passenger actions or reactions.
- Never use near motor vehicles.
- Avoid sharp bumps, drainage grates, and sudden surface changes. Scooter may suddenly stop.
- Avoid streets and surfaces with water, sand, gravel, dirt, leaves, and other debris. Wet weather impairs traction, braking, and visibility.
- Avoid riding around flammable gas, steam, liquid, or dust that could cause fire.
- Operators shall adhere to all of the manufacturer's recommendations and instructions, as well as comply with all laws and ordinances: Units without headlights shall be operated only with adequate daylight conditions of visibility, and; Owners shall be encouraged to highlight (for conspicuity) using lighting, reflectors, and for low-riding units, signal flags on flexible poles.
- Persons with the following conditions shall be cautioned not to operate: Those with heart conditions; Pregnant women; Persons with head, back, or neck ailments, or prior surgeries to those areas of the body; and persons with any mental or physical conditions that may make them susceptible to injury or impair their physical dexterity or mental capabilities to recognize, understand, and perform all of the safety instructions and to be able to assume the hazards inherent in unit use.
- Do not ride at night.
- Do not ride after drinking or taking prescription medication.
- Do not carry items when riding.
- Never operate the product barefooted.
- Always wear shoes and keep shoelaces tied.
- Make sure your feet are always placed securely on the deck.
- Operators always shall use appropriate protective clothing, including but not limited to a helmet, with appropriate certification, and any other equipment recommended by the manufacturer: Always wear protective equipment such as helmet, knee pads, and elbow pads.
- Always give way to pedestrians.
- Be alert to things in front and far away from you.
- Do not allow distractions when riding, such as answering the phone or engaging in any other activities.
- The product cannot be ridden by more than one person.
- When you ride the product along with other riders, always keep a safe distance to avoid a collision.
- When turning, be sure to maintain your balance.
- Riding with improperly adjusted brakes is dangerous and can result in serious injury or death.
- The brake may become hot while operating, do not touch the brake with your bare skin.

- Applying brakes too hard or too suddenly can lock up a wheel, which could cause you to lose control and fall. Sudden or excessive application of the brake may result in injury or death.
- If the brake loosens, please adjust with the hexagon wrench, or please contact Jetson Customer Care.
- Replace worn or broken parts immediately.
- Check whether all safety labels are in place and understood before riding.
- The owner shall allow the use and operation of the unit after a demonstration that such operators can understand and operate all components of the unit before use.
- Do not ride without proper training. Do not ride at high speeds, on uneven terrain, or on slopes. Do not perform stunts or turn abruptly.
- Recommended for indoor use.
- Prolonged exposure to UV rays, rain and the elements may damage the enclosure materials, store indoors when not in use.
- Do not use this product if the flexible power cord or output cable is frayed, has broken insulation, or any other signs of damage.

California Proposition 65

WARNING:

This product can expose you to a chemical such as Cadmium that is known to the state of California to cause cancer or birth defects or other reproductive harm. For more information go to www.p65warnings.ca.gov/product

MODIFICATIONS

Do not attempt to disassemble, modify, repair, or replace the unit or any components of the unit without instruction from Jetson Customer Care. This will void any warranty, and can lead to malfunctions which may cause injury.

ADDITIONAL OPERATION CAUTIONS

Do not lift the product off the ground while it is on and the wheels are in motion. This can result in freely spinning wheels, which may cause injury to yourself or others nearby. Do not jump on or off the product, and do not jump while using it. Always keep your feet firmly planted on the foot rest while in operation. Always check the battery charge before using.

MAINTENANCE CAUTIONS

For all maintenance repairs and needs beyond the capability of the consumer which may include but not limited to such as proper maintenance of brakes, control cables, bearing adjustments, wheel adjustments, lubrication, reflectors, tires and handlebar and seat adjustments, please contact Jetson Customer Care for assistance at: support.ridejetson.com

US & Canada 1-(888) 976-9904

Hours of Operation: 7 days a week 10am-6pm EST

NOTICE OF COMPLIANCE

This device complies with Part 15 of the FCC Rules. Operation is subject to the following two conditions:

(1) this device may not cause harmful interference, and (2) this device must accept any interference received, including interference that may cause undesired operation. Warning: Changes or modifications to this unit not expressly approved by the party responsible for compliance could void the user's authority to operate the equipment.

NOTE: This equipment has been tested and found to comply with the limits for a Class B digital device, pursuant to Part 15 of the FCC Rules. These limits are designed to provide reasonable protection against harmful interference in a residential installation. This equipment generates, uses and can radiate radio frequency energy and, if not installed and used in accordance with the instructions, may cause harmful interference to radio communications. However, there is no guarantee that interference will not occur in a particular installation. If this equipment does cause harmful interference to radio or television reception, which can be determined by turning the equipment off and on, the user is encouraged to try to correct the interference by one or more of the following measures:

- Reorient or relocate the receiving antenna.
- Increase the separation between the equipment and receiver.
- Connect the equipment into an outlet on a circuit different from that to which the receiver is connected.
- Consult the dealer or an experienced radio/ TV technician for help.

Shielded cables must be used with this unit to ensure compliance with the Class B FCC limits.

DISPOSAL OF USED BATTERY



Battery may contain hazardous substances which could endanger the environment and human health. This symbol marked on the battery and/ or packaging indicates that used battery shall not be treated as municipal waste. Batteries should be disposed of at an appropriate collection point for recycling. By ensuring the used batteries are disposed of correctly, you will help preventing potential negative consequences for the environment and human health. The recycling of materials will help to conserve natural resources. For more information about recycling of used batteries, please contact your local municipality waste disposal service.

LIMITED LIFETIME WARRANTY

Limited Life Time Warranty only applies to the Frame & Fork for manufacture defects. Contact Jetson Customer Care for detailed information via support.ridejetson.com

Limited Lifetime Warranty does NOT cover:

- Normal wear and tear
- Improper assembly
- Corrosion
- Improper maintenance
- Installation of components, parts, or accessories not originally intended for or compatible with the bicycle as sold
- Damage or failure due to accident, misuse, abuse, or neglect
- Labor charges for part replacement or changeover
- Non-proprietary products (any other original part or component) covered by the original manufacturer's warranty
- Any accessories, brakes, tires

Safety Checklist

INSTRUCTIONS PERTAINING TO RISK OF FIRE OR ELECTRIC SHOCK.

IMPORTANT SAFETY INSTRUCTIONS

A) READ ALL THE INSTRUCTIONS BEFORE USING THE PRODUCT.

B) TO REDUCE THE RISK OF INJURY, CLOSE SUPERVISION IS NECESSARY WHEN THE PRODUCT IS USED NEAR CHILDREN.

C) DO NOT PUT FINGERS OR HANDS INTO THE PRODUCT. D) DO NOT USE THIS PRODUCT IF THE FLEXIBLE POWER CORD OR OUTPUT CABLE IS FRAYED, HAS BROKEN INSULATION, OR ANY OTHER SIGNS OF DAMAGE.

E) THIS EQUIPMENT IS NOT INTENDED TO BE USED AT AMBIENT TEMPERATURES LESS THAN -20°C (68°F) OR ABOVE AMBIENT TEMPERATURES OF 60°C (140°F).

F) THE BATTERY IS INTENDED TO BE CHARGED WHEN THE AMBIENT TEMPERATURE IS BETWEEN -0°C (32°F) AND 45°C (113°F). NEVER CHARGE THE BATTERY WHEN AMBIENT TEMPERATURES ARE OUTSIDE THIS RANGE. A GENERAL WARNING SHALL BE PROVIDED AGAINST MODIFYING OR ATTEMPTING TO REPAIR THE EBIKE SYSTEM EXCEPT AS INDICATED IN THE INSTRUCTIONS FOR USE AND CARE. IT'S ALWAYS IMPORTANT TO DO A FEW, BUT IMPORTANT, SAFETY CHECKS BEFORE EVERY RIDE.

LET'S GO THROUGH THEM:

BRAKES

CHECK THE BRAKE IS IN GOOD WORKING ORDER. MAKE SURE PEDALS ROTATE BACKWARDS SMOOTHLY AND THAT THE REAR AXLE IS LUBRICATED.

STEERING

CHECK THAT THE HANDLEBAR AND STEM ARE SECURELY TIGHTENED.

CRANKS AND PEDALS

CHECK THAT THE FOOT RESTS ARE SECURELY TIGHTENED TO THE CRANKS AND THAT THE CRANKS ARE TIGHTENED TO THE AXLE.

WHEELS AND TIRES

MAKE SURE THAT THE TIRES ARE INFLATED TO WITHIN THEIR MAXIMUM RECOMMENDED TIRE PRESSURE. CHECK TIRES FOR EXCESSIVE WEAR OR ANY DAMAGE AND THAT THE WHEEL RIMS ARE NOT DAMAGED. CHECK THAT THE WHEEL SPOKES ARE NOT BROKEN AND THAT THE AXLE NUTS ARE TIGHT.

FRAME AND FORK

CHECK THAT THE FRAME AND FORK ARE NOT IN ANY WAY DAMAGED OR BROKEN.

What's in the Box

- | | |
|-----------------------|--------------------|
| 1. HANDLEBAR | 9. REAR FENDER |
| 2. HANDBRAKE | 10. REAR LIGHT |
| 3. STEM QUICK RELEASE | 11. SEAT CLAMP |
| 4. HEADLIGHT | 12. SEAT |
| 5. FRONT FENDER | 13. FOOT RESTS |
| 6. FRONT TIRE | 14. CHARGING PORT |
| 7. KICKSTAND | 15. CHARGER |
| 8. REAR TIRE | 16. CHARGING CABLE |

HARDWARE / TOOLS INCLUDED:



..... BOLT (1X - PRE-ATTACHED IN REAR FENDER)



..... NUT (1X - PRE-ATTACHED IN REAR FENDER)



..... DOUBLE-SIDED WRENCH



..... ALLEN KEY

*ADULTS MUST ASSIST CHILDREN IN THE INITIAL ADJUSTMENT PROCEDURES OF THE PRODUCT.



PLEASE NOTE: IMAGES MAY NOT REFLECT EXACT APPEARANCE OF ACTUAL PRODUCT.

Specs & Features

- PRODUCT UNFOLDED DIMS: 38" × 19" × 36"
- PRODUCT FOLDED DIMS: 38" × 9" × 27"
- PRODUCT WEIGHT: 36 LB
- TIRE SIZE: 10"
- BATTERY: 36V 6AH
- CHARGER: 100-240V
- CHARGE TIME: 3-4 HOURS
- MOTOR: 250W
- MAX SPEED: UP TO 15.5 MPH
- BRAKE TYPE: HAND & DISC BRAKE
- WEIGHT LIMIT: 260 LB
- RECOMMENDED AGE: 12+

Correct Frame Size

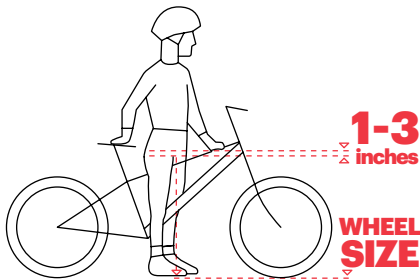

FOR SAFE AND COMFORTABLE RIDING THERE SHOULD BE A CLEARANCE OF AT LEAST 1-3 INCHES BETWEEN THE CROTCH AND THE TOP TUBE OF THE BICYCLE FRAME, WHILE THE RIDER STRADDLES THE BICYCLE WITH BOTH FEET FLAT ON THE GROUND.

⚠ WARNING:

FAILURE TO COMPLY WITH THE FOLLOWING INSTRUCTIONS MAY RESULT IN INJURY TO THE CHILD OR OTHERS.

- KEEP SMALL PARTS AWAY FROM CHILDREN DURING ASSEMBLY.
- ACCESSORY MUST BE ASSEMBLED AND REMOVED BY AN ADULT.
- FREQUENTLY INSPECT THE PRODUCT FOR DAMAGE.

1. Get Started

1.1 Attaching the Seat

- INSERT SEAT POST INTO SEAT TUBE.
SLIDE SEAT INTO STEM TUBE.



- TURN THE KNOB CLOCKWISE TO TIGHTEN SEAT CLAMP. CLOSE THE SEAT CLAMP.



- MAKE SURE SEAT CLAMP IS SECURED AND SEAT IS STABLE.



1.2 Foot Rest Assembly

- INSTALL FOOT RESTS TO AXEL, TURN FOOT RESTS CLOCKWISE TO TIGHTEN

CAUTION: IT'S IMPORTANT TO STOP IF YOU FEEL RESISTANCE WHEN PUTTING ON THE FOOT RESTS. IT COULD MEAN THE SPINDLE IS ENTERING THE CRANK ARM AT AN ANGLE.



FOOT REST



1.3 Attaching the Rear Fender

- REMOVE BOLT AND NUT WHICH COME PRE-ATTACHED TO REAR FENDER.
- RUN THE BOLT THROUGH THE FENDER AND FRAME.
- SECURE USING THE NUT.





1.4 Stay Charged

CHARGING THE BATTERY

- ONLY USE THE INCLUDED CHARGER
- PLUG THE CHARGER INTO THE WALL BEFORE THE CHARGING PORT
- DON'T TURN ON THE LX10 WHILE IT'S CHARGING
- CHARGE THE BATTERY UNTIL IT IS FULLY CHARGED - UP TO 4 HOURS
- REPLACE THE COVER OVER THE CHARGING PORT WHEN DONE

CHARGING PORT

CHARGING INDICATOR ON THE CHARGER:

- - BATTERY IS CHARGING
- - CHARGING IS COMPLETE
- **CHARGING TEMPERATURE:** -0° C (32° F) - 45° C (113° F)
- **DISCHARGING TEMPERATURE:** -20° C (4° F) - 60° C (140° F)
- **STORE TEMPERATURE:** -20° C (4° F) - 45° C (113° F)

2. Make Moves

2.1 Unfolding the Handlebar



- PRESS THE STEM QUICK RELEASE TO THE LOCK POSITION.
- TO FOLD, UNLOCK THE STEM QUICK RELEASE.



STEM QUICK RELEASE

2.2 Operating the LX10

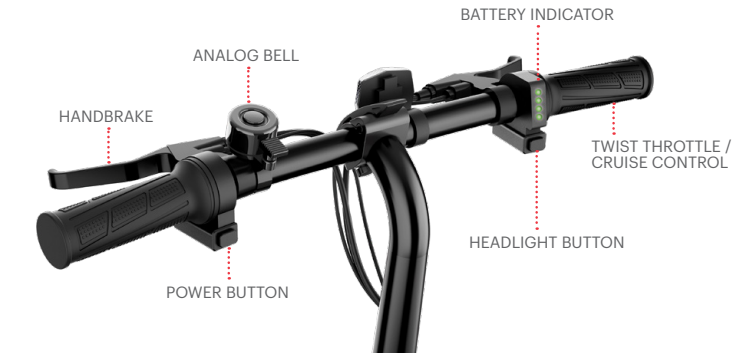

POWER BUTTON: TURNS THE LX10 ON AND OFF

HEADLIGHT BUTTON: PRESS HEADLIGHT BUTTON TO TURN LIGHT ON/OFF

CRUISE CONTROL: TO ACTIVATE CRUISE MODE, TWIST AND HOLD THE TWIST THROTTLE FOR AROUND 6 SECONDS.

BATTERY LEVELS:

- 4 LIGHTS: 76-100% POWER
- 3 LIGHTS: 51-75% POWER
- 2 LIGHTS: 26-50% POWER
- 1 LIGHT: 1-25% POWER (PLEASE CHARGE THE LX10 IMMEDIATELY!)

2.3 Helmet Safety



THE FOREHEAD IS COVERED
BY THE HELMET.



THE FOREHEAD IS EXPOSED.
COULD CAUSE SERIOUS INJURY.

2.4 Riding the LX10



- BEFORE EACH RIDE, CHECK THAT THE HANDLEBAR AND SEAT ARE SECURE, THE TIRE PRESSURE IS SUFFICIENT, AND THE BRAKE SYSTEM WORKS CORRECTLY.
- KEEP YOUR FEET ON THE FOOT RESTS. DO NOT RIDE WITH YOUR FEET DANGLING OVER THE SIDES AND ALWAYS STAY SEATED WHILE RIDING.
- **TWIST THROTTLE:** TRY TO TAKE IT EASY ON THE THROTTLE UNTIL YOU GET USED TO IT.
- **HANDBRAKES:** SQUEEZE EACH BRAKE SLOWLY TO AVOID STOPPING ABRUPTLY OR LOSING CONTROL.

Care & Maintenance

CLEANING THE LX10

- Carefully wipe with a damp cloth, then dry with a dry cloth.
- Do not use water to clean the LX10, as the electrical and electronic systems may get wet, resulting in personal injury or malfunction of the LX10.

BATTERY

- Keep away from fire and excessive heat.
- Avoid intense physical impact and / or severe vibration.
- Protect from water or moisture.
- Do not disassemble.
- If there are any issues with the battery, please contact Jetson Customer Care. We'd love to help!

STORAGE

- Remove batteries before storing.
- Cover to protect against dust.
- Store indoors, in a dry place and at a suitable temperature.

Enjoying the ride?

Leave a review on ridejetson.com/reviews or share your photos with us online using the #RideJetson hashtag!



Follow us @**ridejetson**
#MakeMoves

JETSON

Questions? Let us know.

support.ridejetson.com

Hours of Operation:
7 Days a Week, 10am-6pm

Manufactured in Shenzhen, China.
Imported by Jetson Electric Bikes LLC.
86 34th Street 4th Floor, Brooklyn, New York 11232

www.ridejetson.com



Made in China
Date Code: 08/2021