

FISHER & PAYKEL

PRELIMINARY SPECIFICATION GUIDE

DOUBLE DISHDRAWER™ DISHWASHER, TALL



OVERVIEW

Our built-under DishDrawer™ Dishwashers are installed flush under the countertop with the option of a custom kickstrip, ensuring minimal gaps. Designed to match the Fisher & Paykel family of kitchen appliances with recessed handles for a streamlined look. With a combination of clever technology and simple mechanics, this series 7 DishDrawer™ Dishwasher ensures greater reliability and better wash performance.

* Energy and water rating to be confirmed

* Noise subject to change

MODELS

**Recessed Handle Double DishDrawer 60cm,
Stainless Steel door panel, Front User Interface**
DD24DT2NX9

SERIES & STYLE

Series 7

Contemporary

FEATURES

- ① Designed to be installed under the countertop, with recessed handles for a seamless look
- ② Flush fit with cabinetry with the option to add a custom kickstrip, ensuring minimal gaps
- ③ Intuitive control panel with capacitive touch controls
- ④ Each drawer operates independently and holds a true half load for small, fast washing
- ⑤ Seven wash programs, as well as additional Quick, Sanitize and Dry+ modifiers
- ⑥ Running at a low decibel rating, this dishwasher does the job without making a fuss
- ⑦ Flexible racking allows for shelf customisation to suit
- ⑧ Sanitize option provides extra protection, killing 99.9% of bacteria in the final rinse
- ⑨ Wi-Fi enabled and works with the SmartHQ™ app for remote control and notifications

ACCESSORIES

- ① Cutlery basket included

FISHER & PAYKEL

PRELIMINARY SPECIFICATION GUIDE

DOUBLE DISHDRAWER™ DISHWASHER, TALL

SPECIFICATIONS

Model No.	DD24DT2NX9
Dimensions	H 34" - 36 3/8" W 23 9/16" D 22 9/16"
Weight	139lbs
Electrical	
Supply	110 - 120VAC, 60Hz
Service	9.6A
Outlet	3-prong grounding type
Plumbing	
Supply	Supplied hose to suit 3/8" (9mm) male compression fitting
Pressure	Max. 1 MPa (145psi), min. 0.03 MPa (4.3psi) Max hot water temperature 140°F/60°C

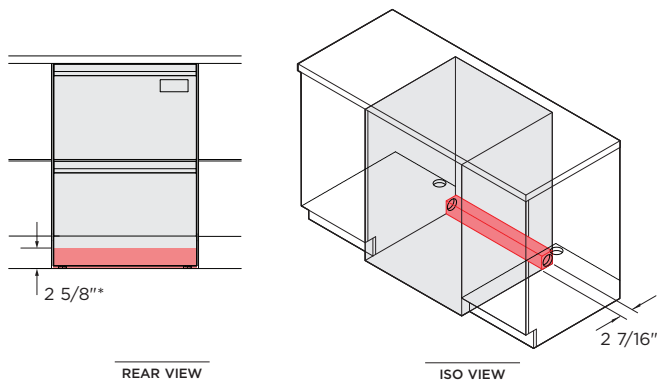

Service outlet at rear extends both sides, hoses and cords can be routed to either or both sides. Units shown in inch.

*depending on adjustment of leveling feet

PRODUCT DIMENSIONS

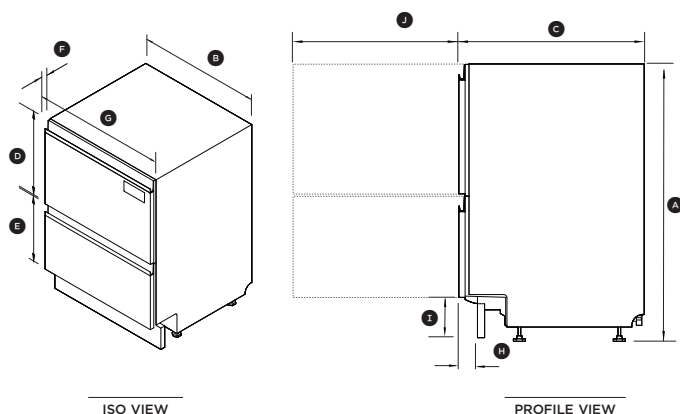

CAVITY DIMENSIONS: STANDARD INSTALLATION

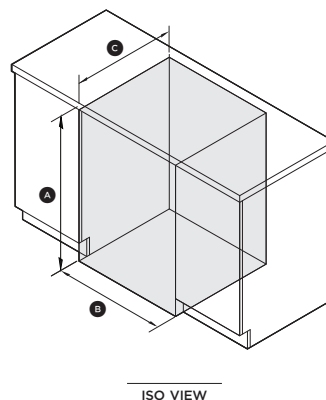

	inch
(A) Overall height*	34 - 36 3/8
(B) Overall width	23 9/16
(C) Overall depth**	22 9/16
(D) Height of upper front panel	17 3/8
(E) Height of lower front panel	12 3/16
(F) Depth of front panels	13/16
(G) Width of front panel	23 7/16
(H) Depth of toe kick recess	1 9/16 - 2 3/16
(I) Height from floor to front panel base*	3 15/16 - 6 5/16
(J) Depth of open drawer	21 9/16

	inch
(A) Overall height*	min 34
(B) Overall width	23 5/8
(C) Overall depth	min 22 1/16

*depending on adjustment of levelling feet

*depending on adjustment of levelling feet

**Including front door panel