



TYTUS

ROTISSERIE KIT

Model No.: A10001

This manual contains important step by step instructions for the proper assembly and installation of the TYTUS Grills rotisserie. Read and follow all warnings and instructions before assembling, installing and using the appliance. Keep these instructions for future reference.

⚠ WARNING: Always refer to the Owner's Manual for your grill, provided by the original grill manufacturer. Read and follow all warnings and instructions in the Owner's Manual before installing this product. If you need a replacement Owner's Manual, contact TYTUS Grills at support@tytusgrills.com.

TYTUS



IMPORTANT SAFETY WARNINGS

READ ALL SAFETY WARNINGS, ASSEMBLY AND INSTALLATION INSTRUCTIONS CAREFULLY BEFORE ASSEMBLING OR OPERATING YOUR ROTISERIE.

WARNING

ELECTRICAL GROUNDING INSTRUCTIONS:

This appliance is equipped with a three-prong grounding plug for your safety and protection against possible electrical shock. It must be correctly plugged directly into a properly grounded three-prong receptacle. DO NOT cut, remove or alter the grounding prong from the plug.

- Prior to each use, ensure the grill and rotisserie are safe to operate by following the safety warnings and instructions contained in this manual and the Owner's Manual for your grill.
- For outdoor use only.
Keep children and pets a safe distance away from the grill. DO NOT allow children to use or play near the grill or rotisserie.
- DO NOT leave the grill unattended while in use.
- DO NOT use the side or sear burner when using a rotisserie. The burner lid could be hot from use.
- To avoid bodily injury, DO NOT touch the spit rod while in use or soon after because the rod will be EXTREMELY HOT.
- Keep all electrical cords away from water or hot surfaces.
- DO NOT operate this appliance with a damaged cord or plug.
- Turn ROTISERIE motor switch to the "OFF" position before removing the plug from the outlet.
- Unplug the rotisserie motor when not in use and before cleaning.
- DO NOT exceed 12 lbs. of food on the rotisserie.
- Keep a fire extinguisher that is designated for use with gas product close by. Refer to your local fire authorities to determine the proper type and size.
- This appliance is for use with your barbecue grill only. DO NOT use the grill or this ROTISERIE for anything other than its intended purpose.
- DO NOT use while under the influence of drugs or alcohol.
- When using the AC current rotisserie, it must be electrically grounded in accordance with local codes, or in the absence of local codes:
 - In the US: The National Electrical Code – ANSI-NFPA No. 70 – Latest Edition
 - In Canada: the Canadian Electrical Code – CSA C22.1
- Use only a Ground Fault Interrupter (GFI) Protected circuit with this outdoor cook gas appliance.

ALWAYS USE CAUTION AND COMMON SENSE WHEN OPERATING YOUR GAS GRILL. FAILURE TO ADHERE TO THE SAFETY WARNINGS AND INSTRUCTIONS PROVIDED IN THIS MANUAL, AND THOSE CONTAINED IN THE OWNER'S MANUAL FOR YOUR GRILL, COULD RESULT IN SEVERE BODILY INJURY OR PROPERTY DAMAGE.

SAVE THIS MANUAL FOR FUTURE REFERENCE.

TYTUS

IF MISSING OR DAMAGED PARTS, PLEASE CONTACT CUSTOMER SERVICE AT SUPPORT@TYTUSGRILLS.COM. PROOF OF PURCHASE WILL BE REQUIRED.

INSTALLATION INSTRUCTIONS

Inspect contents of the box to ensure all parts are included and undamaged.

READ ALL SAFETY WARNINGS, ASSEMBLY AND INSTALLATION INSTRUCTIONS CAREFULLY BEFORE ASSEMBLING OR OPERATING YOUR ROTISERIE.

READ THE OWNERS MANUAL FOR THE GRILL BEFORE ASSEMBLING OR USING THIS ROTISERIE.

THE FOLLOWING TOOLS ARE REQUIRED TO ASSEMBLE THIS ROTISERIE:

- Phillips & Flathead Screwdrivers
- Adjustable Wrench

PARTS LIST: Rot. Screw #10-24x1" UNC x2
Rot. Nut #10-24 x2
Rot. Thumbscrew 1/4" x 1/2" x3
Holding Forks x2
Spit x1
Motor Bracket x1
Motor x1
Collar x1



Spit x1

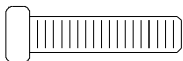

Rot. Screw x2



Rot. Nut x2

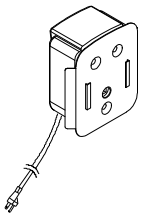

Rotisserie Motor x1

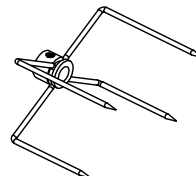

Holding Forks x2

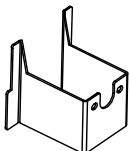

Motor Bracket x1



Collar x1

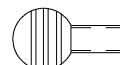

Thumb Screws x3

TYTUS

IF MISSING OR DAMAGED PARTS, PLEASE CONTACT CUSTOMER SERVICE AT SUPPORT@TYTUSGRILLS.COM. PROOF OF PURCHASE WILL BE REQUIRED.

INSTALLATION INSTRUCTIONS

Step 1

Open grill hood and remove the secondary cooking grate.

Step 2

Remove all components from the rotisserie package.

Step 3

Attach the motor bracket on the outside of the left grill box panel. Align the two holes of the bracket with the holes on the grill box panel. Tighten securely using provided screws and nuts.

Step 4

Slide a holding fork onto each end of the rotisserie spit. Adjust spacing between holding forks to accommodate your food, then tighten the thumb screws to keep the holding forks in position. Slide the collar onto the threaded end of the spit. Do not tighten the collar thumb screw until the rotisserie is placed into your grill.

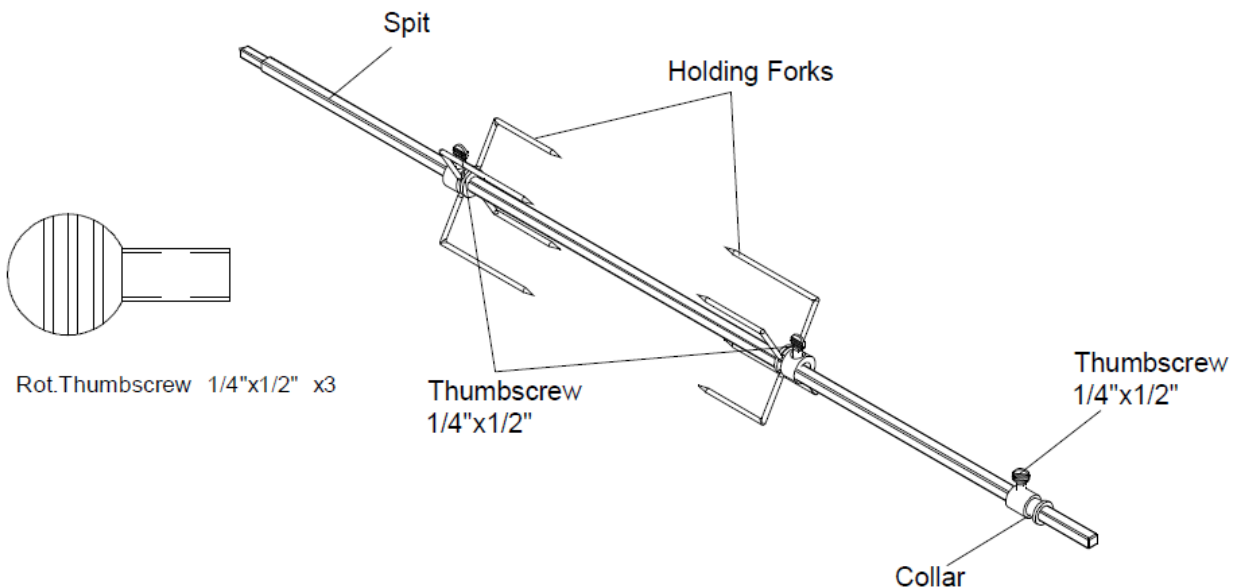
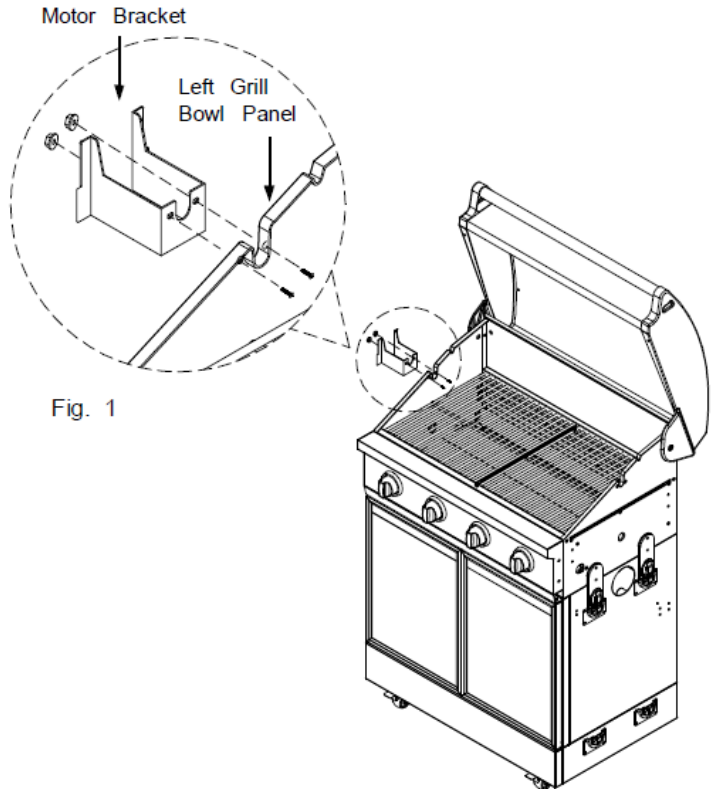

TYTUS

IF MISSING OR DAMAGED PARTS, PLEASE CONTACT CUSTOMER SERVICE AT SUPPORT@TYTUSGRILLS. PROOF OF PURCHASE WILL BE REQUIRED.

INSTALLATION INSTRUCTIONS

Step 5

Install the AC alternating current rotisserie motor onto the motor bracket as shown in the image to the right. Be sure the motor attaches to the bracket with the electrical cord down.

Step 6

Insert the assembled rotisserie into the motor as shown. The motor should be on the left side of your grill. Place the collar into the slot opening on collar support bracket, then tighten the collar thumb screw on the left end of the collar. The collar will stabilize the rotisserie during the cooking process and allows the rotisserie spit to turn smoothly. Plug the rotisserie cord into a properly grounded outlet, then turn on to test operation.

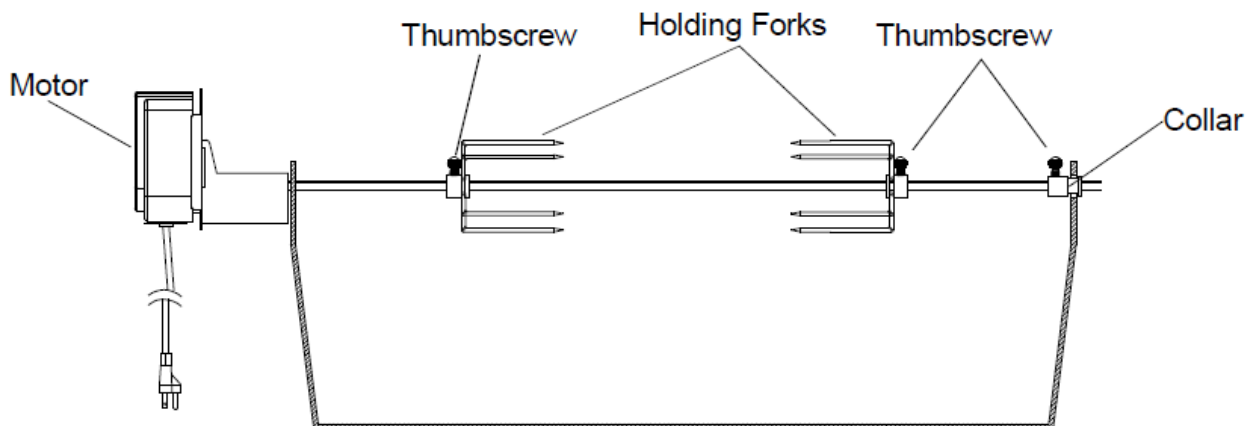
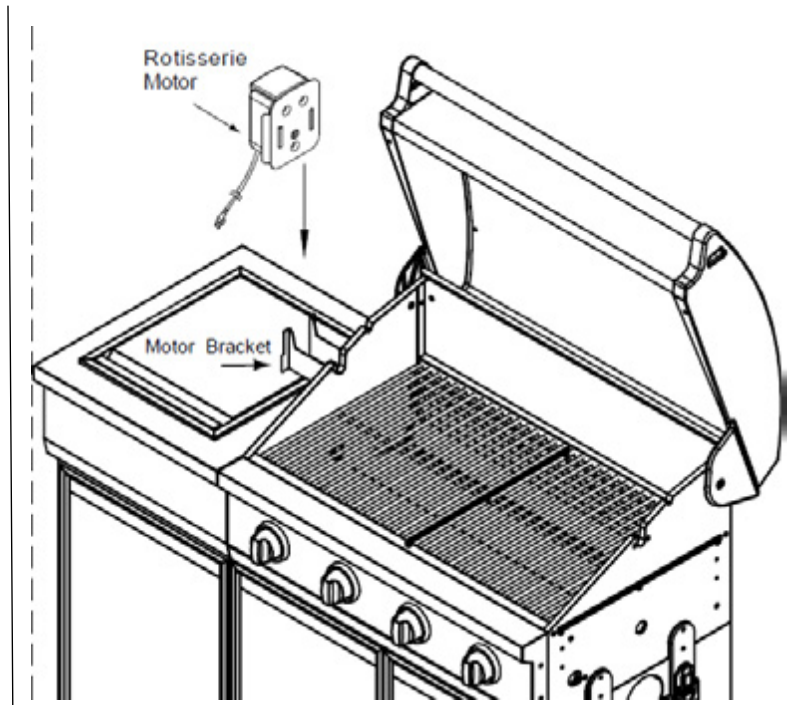

NOTE: The collar must always be used with the TYTUS Rotisserie.

NOTE: BEFORE rotisserie cooking you will need to remove the secondary cooking rack from your TYTUS grill. When rotisserie cooking, place a cooking pan under the food to be cooked. This will capture the drippings and keep your grill clean of excess grease which could cause a fire. Use caution when moving a cooking pan containing hot oils.

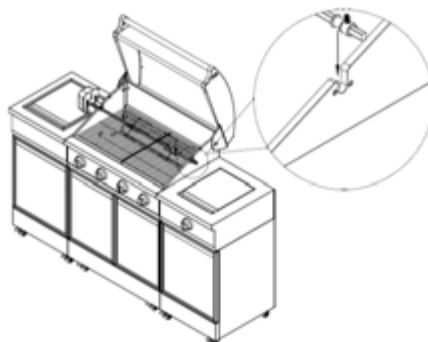

TYTUS

IF MISSING OR DAMAGED PARTS, PLEASE CONTACT CUSTOMER SERVICE AT SUPPORT@TYTUSGRILLS.COM. PROOF OF PURCHASE WILL BE REQUIRED.

READ ALL WARNINGS IN THE OWNER'S MANUAL FOR YOUR GRILL.

⚠ WARNING

ELECTRICAL GROUNDING INSTRUCTIONS:

This appliance is equipped with a three-prong grounding plug for your safety and protection against possible electrical shock. It must be correctly plugged directly into a properly grounded three-prong receptacle. DO NOT cut, remove or alter the grounding prong from the plug.

OPERATION THE ROTISERIE:

1. Your grill was pre-drilled from the factory to include mounting holes for the TYTUS Rotisserie.
2. Install the rotisserie motor onto the motor mount bracket by following the instructions contained in this manual.
3. Ensure that the rotisserie motor is switched to the "OFF" position.
Note: The rotisserie motor is capable of turning up to 25 lbs. of meat.
4. Holding the spit rod, place one fork onto the rod with the forks pointing away from the motor and slide the fork to the center of the rod.
5. Skewer meat with the spit rod and slide the meat to the center of the rod.
6. Place second fork onto the spit rod with the prongs facing the meat.
7. Slide both forks tightly against the meat and securely in place by tightening the fork set screws.
8. Check the balance of the food on the rod by rotating the loaded spit rod loosely in your hands. The rod should rotate evenly with little effort. Adjust the food accordingly on the spit to achieve a balanced assembly.
9. Place the loaded spit rod into the motor assembly and support bracket.
10. Close the grill lid and turn the rotisserie motor "ON".
Note: Erratic noises from the motor are a sign of an unbalanced spit rod, which could cause severe damage to the motor gears. If you hear erratic noises, turn the rotisserie off and readjust the meat.
11. Always turn the ROTISERIE motor to "OFF" before opening the grill lid.
12. When the food is cooked, use oven mitts/gloves to remove spit rod from motor assembly.
13. Loosen the fork thumb screws and remove the fork opposite the rotisserie motor. Then remove the meat by sliding it off the end of the spit rod.

⚠ WARNING: Always use oven mitts/gloves to protect your hands. Metal parts become hot during use. Use extreme caution when handling spit rod and forks to prevent bodily injury.

CLEANING AND MAINTENANCE:

- Spit rod and forks can be disassembled and washed in dish soap and warm water.
Note: All metal parts, with exception of the motor, are dishwasher safe.
- After first use, it is likely that the stainless steel adjacent to the burner will darken. This is a normal property of stainless steel used on the rotisserie.
- Store motor and other parts in a cool, clean and dry place.
- To prevent electrical shock hazard, DO NOT immerse the motor or cord in water.