

CORA™ 1172

COFFEE TABLE

INSTRUCTION MANUAL

LET'S GET STARTED.

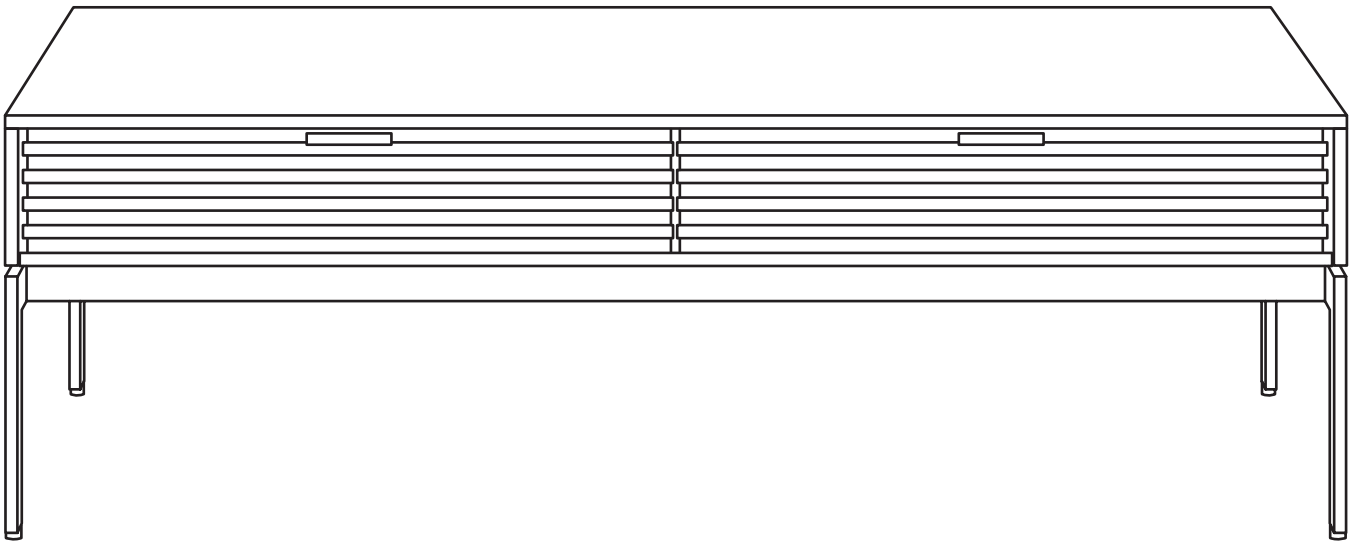

DESIGN MATTHEW WEATHERLY

BDi

BDIUSA.COM



Congratulations on the purchase of your Cora Coffee Table from BDI. Your coffee table has been designed to provide a lifetime of enjoyment. This manual will provide assembly instructions and other helpful information to ensure you get the most out of your product. Please save it for future reference.

Your Cora Coffee Table has been engineered for simple assembly. Please follow these directions carefully to prevent any damage.

Should you need further assistance, contact BDI at customerservice@bdiusa.com.

ENJOY!

HARDWARE AND COMPONENTS

Unpack and identify the parts listed below. The assembly workspace should be a non-marring surface, such as carpet. For missing hardware pieces, please contact BDI Customer Service at customerservice@bdiusa.com. For all other concerns, please contact your BDI retailer.

Do not use power tools for the assembly of this product.



TOOL REQUIRED (NOT INCLUDED)

Phillips Screwdriver



Hex Wrench (T1)

QTY: 1



Screw M6 x 16 (H1)

QTY: 8



Screw M6 x 10 (H2)

QTY: 8

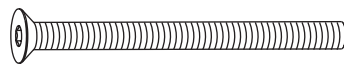

Screw M6 x 70 (H3)

QTY: 8



Wood Screw (H4)

QTY: 4

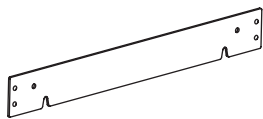

Connection Plate (C1)

QTY: 2

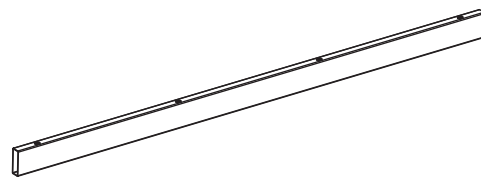

Spanner Tube (C2)

QTY: 2

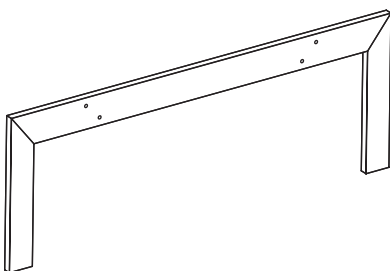

Leg (C3)

QTY: 2

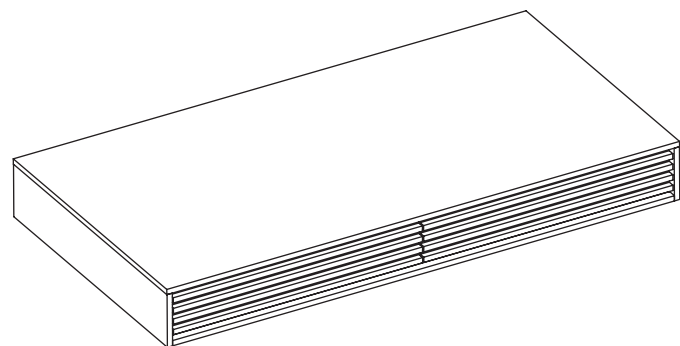

Coffee Table Case (C4)

QTY: 1

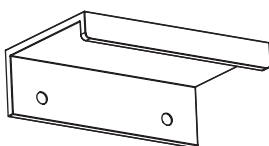



Drawer Pull (C5)

QTY: 2

STEP 1. CREATE BASE

ASSEMBLY

Attach the **Connection Plates (C1)** to the **Spanner Tubes (C2)** using **8 Screws (H1)**. Ensure that the **open slots** in the **Connection Plates are facing up**. Tighten with **Hex Wrench (T1)**.

	HEX WRENCH – T1	QTY 1
	SCREW – H1	QTY 8

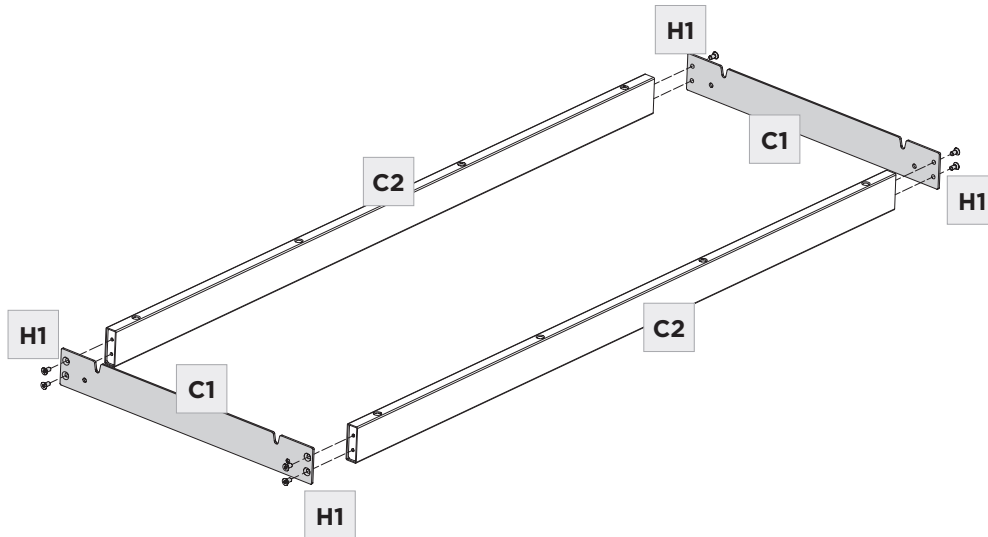

STEP 2. PREPARE LEGS

ASSEMBLY

Partially thread **2 Screws (H2)** into the lower, closer together set of holes in the cross bar of each **Leg (C3)** as shown.

Leave at least 1/4" (6mm) gap between the head of the screw and the leg.

	SCREW – H2	QTY 4
---	------------	----------

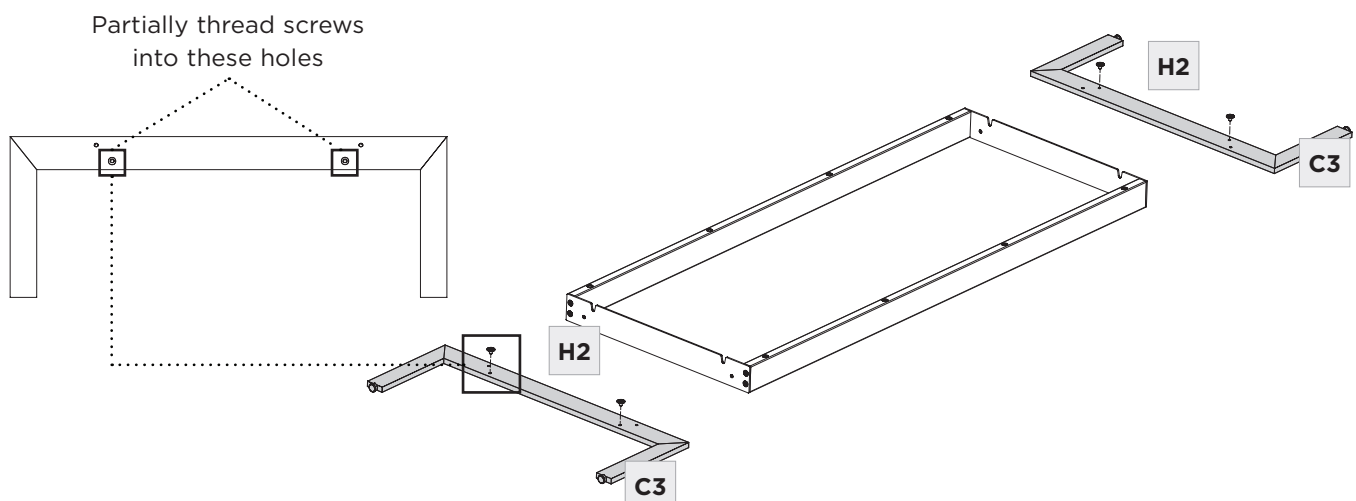

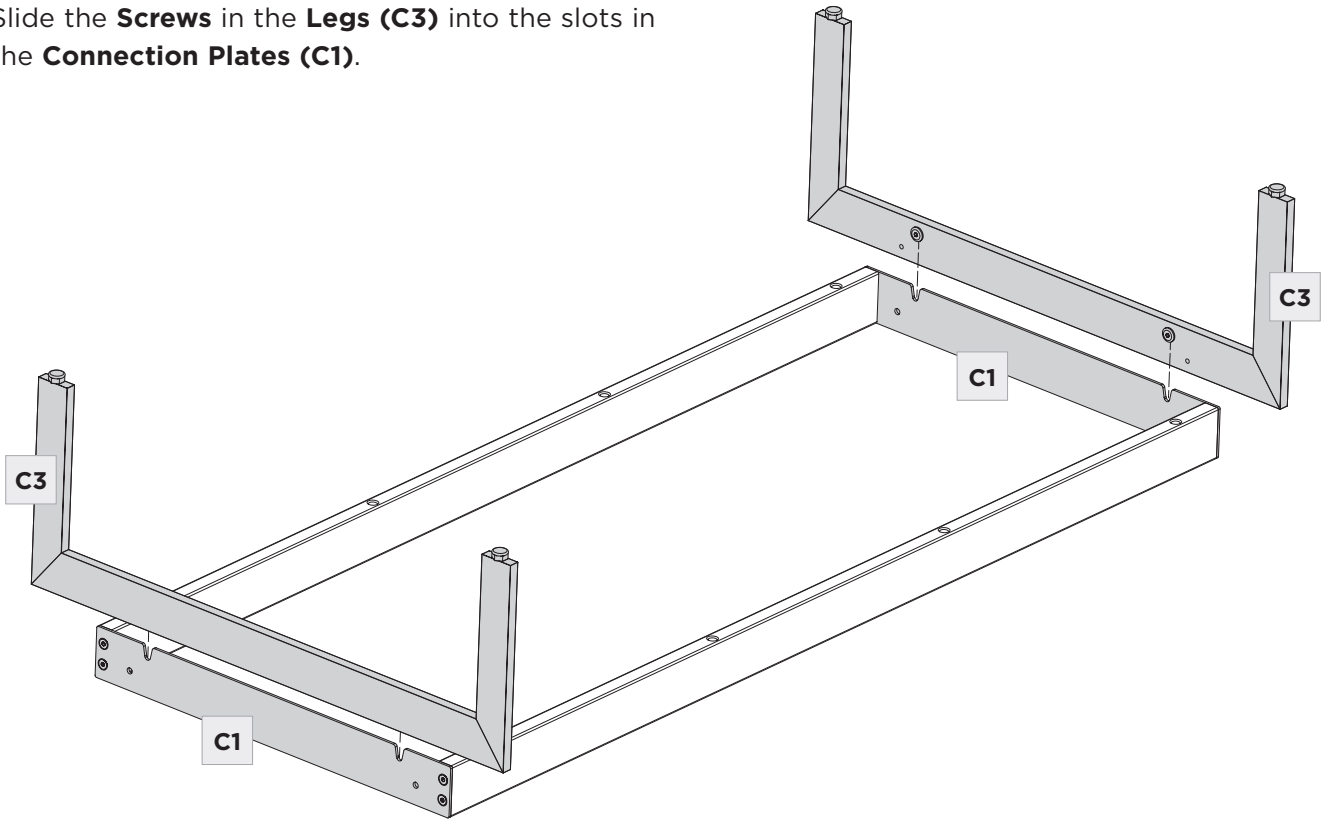

Slide the **Screws** in the **Legs (C3)** into the slots in the **Connection Plates (C1)**.



Thread the remaining **4 Screws (H2)** into the holes in the **Legs (C3)**.

Tighten all screws with **Hex Wrench (T1)**.

	HEX WRENCH – T1	QTY 1
	SCREW – H2	QTY 4

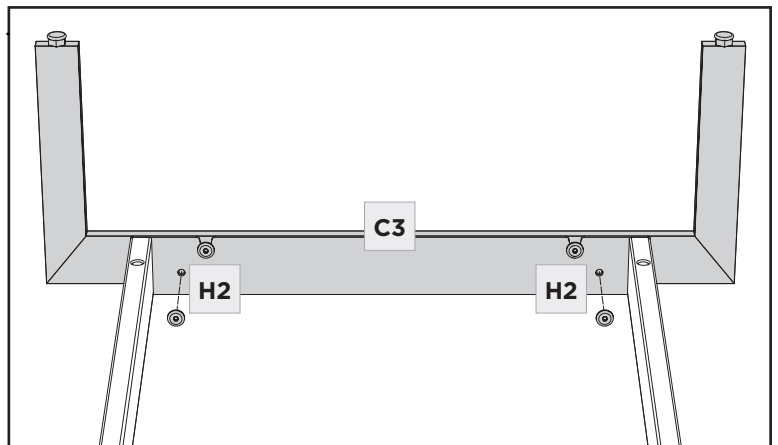
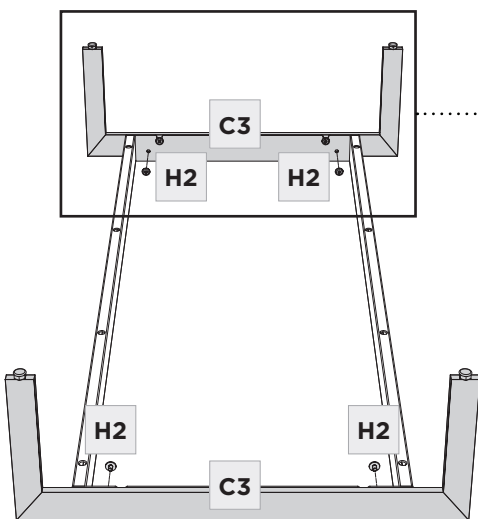

STEP 4. ATTACH BASE ASSEMBLY TO COFFEE TABLE CASE

ASSEMBLY

	HEX WRENCH – T1	QTY 1
	SCREW – H3	QTY 8

Attach the **Base Assembly** to the **Coffee Table Case (C4)** with **Screws (H3)**. Tighten with **Hex Wrench (T1)**.

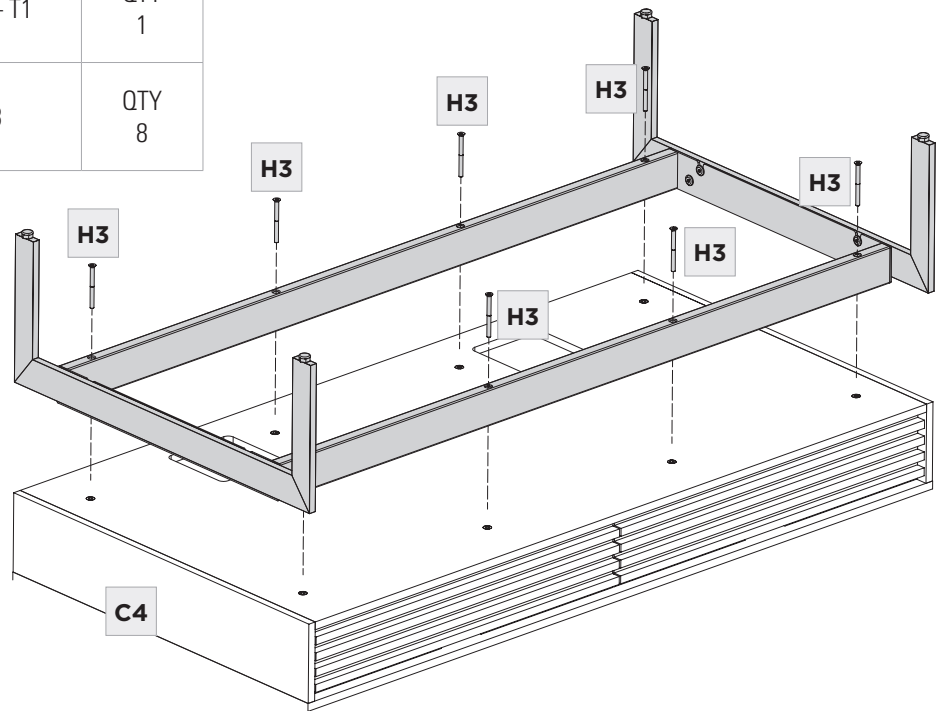



STEP 5. INSTALL DRAWER PULLS

ASSEMBLY

With help from another person, carefully flip the table onto its base. Open the drawers and install the **2 Drawer Pulls (C5)** using **4 Wood Screws (H4)**.

Tighten with **Phillips Head Screwdriver (not included)**.

	NOT INCLUDED PHILLIPS SCREWDRIVER	QTY 1
	WOOD SCREW – H4	QTY 4

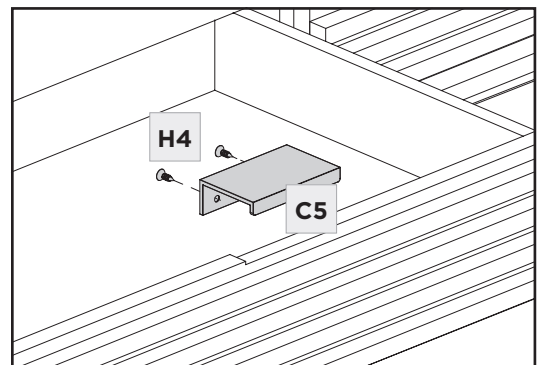
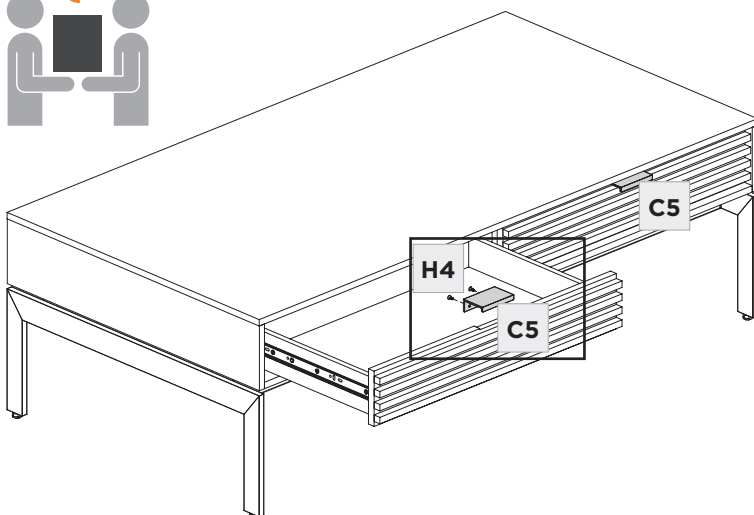
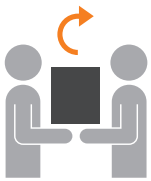

CARE & MAINTENANCE

Your BDI furniture has been constructed with the finest materials, carefully manufactured, and designed to last a lifetime. Regular furniture care will prolong your enjoyment and keep it looking its best. Here are some general tips for taking care of BDI furniture. Your surfaces may vary.

WOOD

Wood surfaces should be cleaned with a slightly damp (not saturated) cloth or paper towel. Do not use glass cleaner on wood. If moisture remains, dry the surface with another cloth. If needed, a gentle, non-abrasive cleanser may be used, but wipe away all cleaner residue and dry the surface with a cloth.

BDI's wood finishes feature natural hardwood solids and veneers. Wood is a product of nature and—unlike man-made materials that can be manufactured to strict and consistent specifications—has natural imperfections that are part of its appeal and character. Every piece of wood differs from every other, even when coming from the very same tree. As such, grain, texture, and tone variation should be expected from one panel or piece of furniture to the next.

While BDI's stained wood finishes are stable in tone & appearance, all finishes are subject to some degree of discoloration with prolonged exposure to direct sunlight. Please avoid positioning your BDI cabinet in any area with ample direct sunlight. To learn more about the features of natural wood, visit www.bdiusa.com/wood

METAL, PORCELAIN, & PAINTED SURFACES

Surfaces should be cleaned with a slightly damp (not saturated) cloth or paper towel. If moisture remains, dry the surface with another cloth. If needed, a gentle, non-abrasive cleanser may be used, but be sure to wipe away all cleaner residue and dry the surface with a cloth.

WARRANTY

BDI warrants to the original purchaser that for the below-stated warranty term, BDI will repair or replace any product, part, or component covered by this warranty that fails under everyday use due to a defect in material or workmanship. BDI will repair or replace the product mentioned above, part, or component with a comparable product, part, or component. The decision to repair or replace will be at BDI's sole discretion.

BDI furniture is warranted for three (3) years from the date of purchase, as shown on your sales receipt. The warranty period starts from the date of purchase. This warranty extends only to the original purchasers who acquire new products from BDI Authorized Resellers. To be eligible for warranty coverage, any product, part, or component must have been assembled, installed, used, and maintained according to BDI's published instructions. Any modification to the original product voids the warranty.

To view BDI's complete warranty information, visit www.bdiusa.com/warranty

PRODUCT REGISTRATION

Registering your new BDI product allows us to send you important product updates, service information, and helpful hints related to your BDI products. Register today, and you will be entered to win free a BINK table from BDI: www.bdiusa.com/register



BDIUSA.COM

These distinctive product configurations are protected by US and international patents, trade dress, and/or copyright laws. Cora & BDI are trademarks of Becker Designed, Inc. All rights reserved. ©2023, BDI | V.08.24.2023

Made in Turkey.