

# Built-in Trim Kit

---

## Installation Instructions

MA-TK8020\*\*

---



**SAMSUNG**

## Contents

---

Before you begin	2
Parts included in the kits	3
Tools needed	3
Installation	4

## Before you begin

---

Read these instructions completely and carefully.

### IMPORTANT

---

- Save these instructions for local inspector's use.
- Observe all governing codes and coordinates.
- Be sure to disconnect the plug of the microwave oven from the electrical outlet before installing the Built-in Kit. Remove the turntable from the oven cavity.
- The kit includes metal parts, due caution should be used in handling and installation to avoid the possibility of injury.
- Do not remove permanently affixed labels, warnings or plates from the product. Doing so may void the warranty.

### WARNING

The electrical requirements for this oven are 115-120 volts AC, 15 amps or larger.

## Parts included in the kits

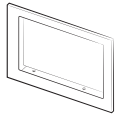

Trim Frame (1 EA)

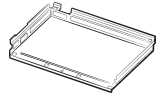

Duct Base (1 EA)



Duct Side (1 EA)

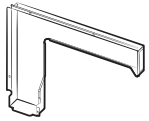

Duct Rear (1 EA)

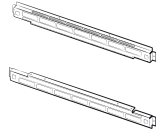

Install Bracket (2 EA)

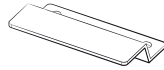

Install hook

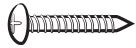

Screw A  
(5/8" length) (12 EA)



Screw B  
(15/32" length) (4 EA)



Screw C  
(25/64" length) (9 EA)



Template (1 EA)

## Tools needed



Screwdriver



Pencil

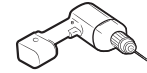

Drill with 7/64 or #35 Drill bit



Scissors



Tape measure



T15H Torx driver

Parts included in the kits

# Installation

## STEP 1

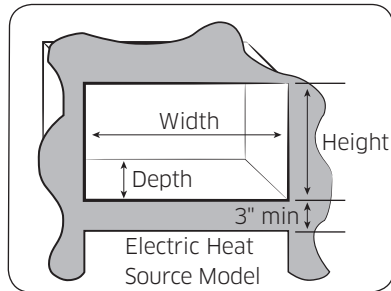

### CUTOUT DIMENSIONS

Height	16 3/4" ± 1/16"
Width	25 1/2" ± 1/16"
Depth	21 1/2" ± 1/16"

### TRIM DIMENSIONS

Height	20 1/16" ± 1/64"
Width	29 3/4" ± 1/64"
Depth	1 1/4" ± 1/64"

### TRIM WEIGHT

Net Weight	13.23 lb
------------	----------

### ⚠ WARNING

To avoid risk of electrical shock, personal injury, or death:

- Before drilling into the wall, note where electrical outlets are and where electrical wire might be concealed behind the wall. **YOU COULD GET AN ELECTRICAL SHOCK if you contact electrical wire** with the drill bit.
- Locate and disconnect the power to any electrical circuits that could be affected by installing this oven.

**IF YOU DO NOT DISCONNECT THE POWER, YOU COULD GET AN ELECTRICAL SHOCK.**

### ⚠ WARNING

To avoid personal injury, wear gloves when handling the metal parts. Parts are sharp and can cause cuts and abrasions.

## STEP 2

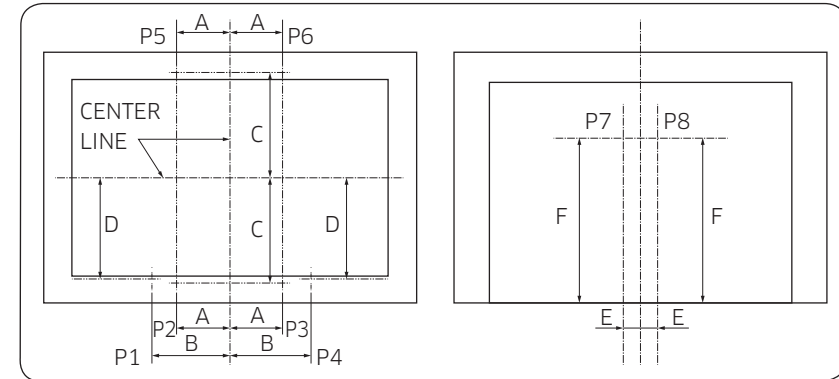

A : 5 1/8" (130 mm)

B : 6 7/8" (175 mm)

C : 9 3/8" (238.5 mm)

D : 8 23/32" (221.3 mm)

E : 7/8" (23 mm)

F : 16 1/8" (409.5 mm)

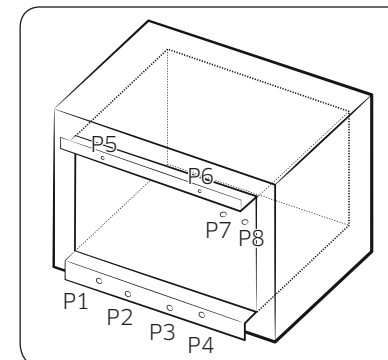

1. Folding the underline of Template and match with the cabinet edge line, mark 6holes at bottom. (P1,2,3,4,7,8)
2. Folding the topline of Template and match with the cabinet edge line, mark 2holes at top. (P5,6)
3. Then drill a pilot hole at the 8positions using 7/64 or #35 drill bit.

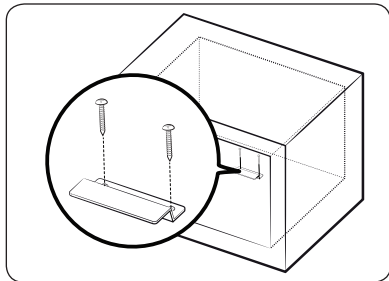

4. Tight 2 screws together on the Install hook by using provided SCREW A. (2 EA)

**NOTE**

You may not be assembled when using the thicker Drill bit.

**STEP 3**

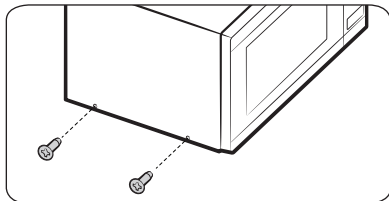

5. Remove 4 screws from the lower right and left side of outer panel.

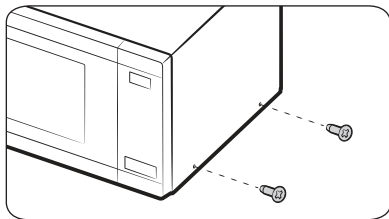

**STEP 4**

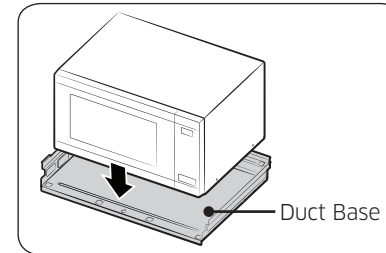

1. Place oven on the Duct Base.

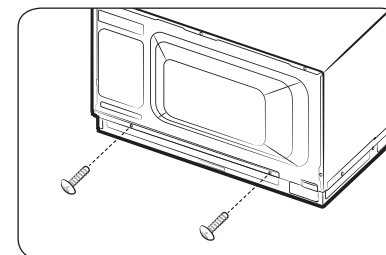

2. Tight 2 screws together on the back side with Duct base by using provided SCREW C. (2 EA)

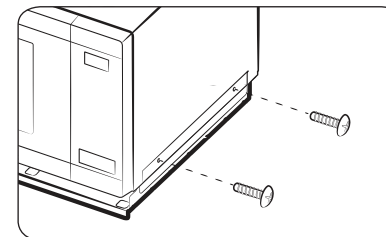

3. Tight 2 screws together on the right side with Duct base by using provided SCREW C. (2 EA)

# Installation

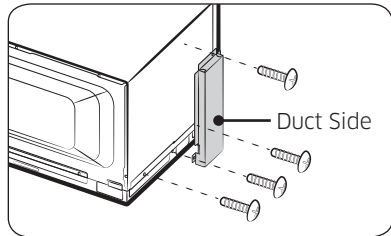

4. Tight 4 screws to Duct base and Duct side on the left side by using provided SCREW C. (4 EA)

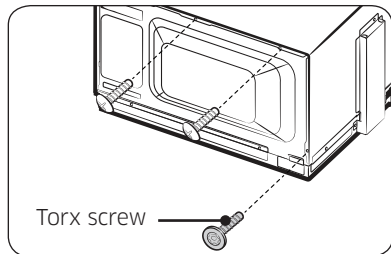

5. Remove 2 Screw C on top of the back. In addition, Remove 1 Torx Screw to use Torx driver on bottom of the back. Do not scrap Screw. (3 EA)

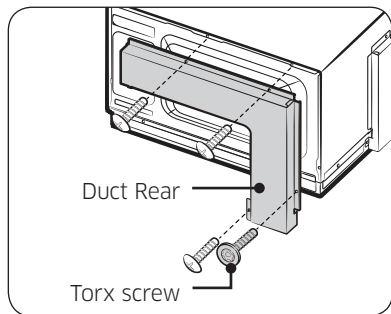

6. Tight a Torx Screw and 3 Screw C on top of the back.

## STEP 5

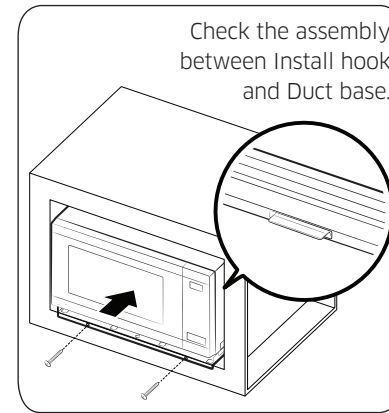

1. Slide the oven with Duct Base into cabinet until Duct Base touch the front of cabinet.
2. Plug the Power cord into the electrical outlet.
3. Tight 2 screws to Duct base and Cabinet by using provided SCREW A. (2 EA)

### NOTE

Be aware when you put a oven into the cabinet because cabinet may be moved.

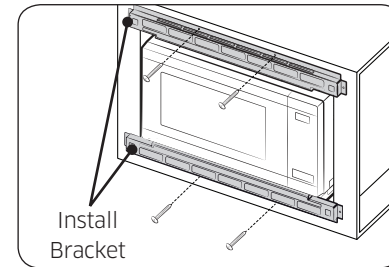
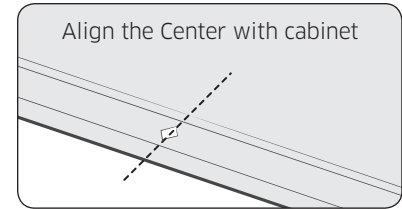

4. After placing the Install Bracket to match with holes, tight together by using provided SCREW A. (4 EA)

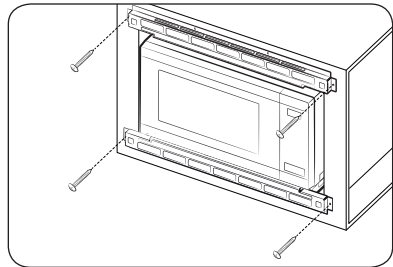

5. Tight Install Bracket 4 holes by using provided SCREW A. (4 EA)

## STEP 6

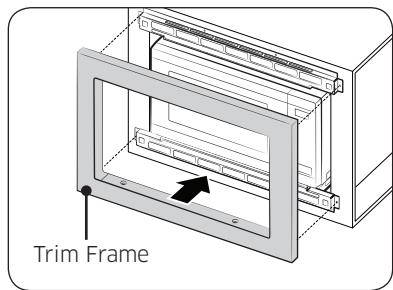

1. Press the Trim Frame into the opening until all sides snap into place.

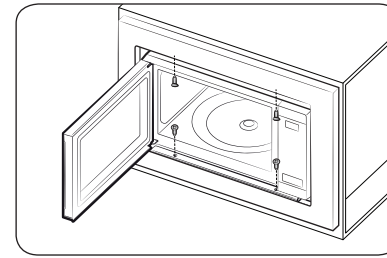
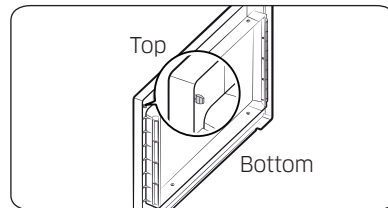

2. Open the oven door. Tight 4 screws Trim frame by using provided SCREW B. (4 EA)

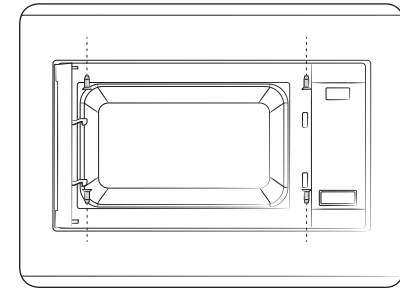
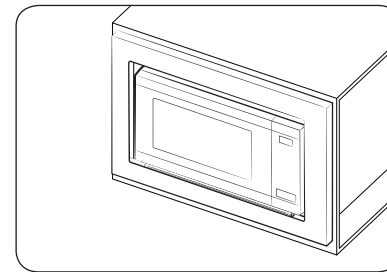

**SAMSUNG**



DE68-04476A-02



# Kit de marco embellecedor para empotrar

---

## Instrucciones de instalación

MA-TK8020\*\*

---



**SAMSUNG**

## Contenido

---

ANTES DE COMENZAR	2
Piezas incluidas en los kits	3
Herramientas necesarias	3
Instalación	4

## ANTES DE COMENZAR

---

Lea estas instrucciones con detenimiento en su totalidad.

### IMPORTANTE

---

- Conserve estas instrucciones para que puedan ser consultadas por el inspector de su localidad.
- Cumpla todos los códigos y coordenadas exigidos por las autoridades pertinentes.
- Asegúrese de desconectar el enchufe del horno de microondas del tomacorriente antes de instalar el kit para empotrar. Retire el plato giratorio de la cavidad del horno.
- El kit incluye piezas metálicas, por lo que debe tener cuidado durante el manejo y la instalación para evitar el riesgo de lesiones.
- No elimine del producto ninguna etiqueta, advertencia o placa adherida permanentemente. Hacerlo puede anular la garantía.

### ADVERTENCIA

Los requisitos eléctricos para este horno son 115-120 voltios CA, 15 amperios o superior.

## Piezas incluidas en los kits

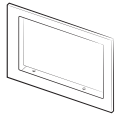

Marco embellecedor  
(1 ud.)

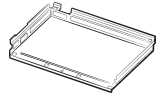

Conducto base (1 ud.)



Conducto lateral (1 ud.)

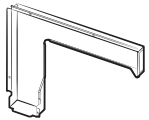

Conducto posterior (1 ud.)

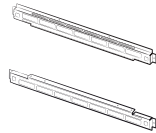

Ménsula de instalación  
(2 uds.)



Gancho de instalación



Tornillo A  
(5/8" largo) (12 uds.)



Tornillo B  
(15/32" largo) (4 uds.)



Tornillo C  
(25/64" largo) (9 uds.)



Plantilla (1 ud.)

## Herramientas necesarias



Destornillador



Lápiz

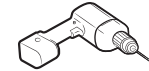

Perfore con mecha de 7/64  
o #35.



Tijeras



Cinta de Medir



Destornillador Torx T15H

Piezas incluidas en los Kits

# Instalación

## STEP 1

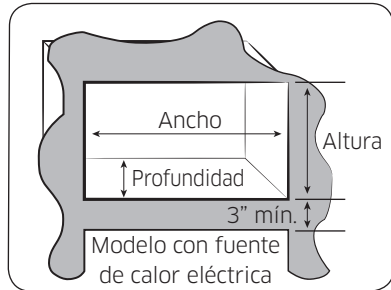

### DIMENSIONES DE LA ABERTURA RECORTADA

Altura	16 3/4" ± 1/16"
Ancho	25 1/2" ± 1/16"
Profundidad	21 1/2" ± 1/16"

### DIMENSIONES DEL BORDE

Altura	20 1/16" ± 1/64"
Ancho	29 3/4" ± 1/64"
Profundidad	1 1/4" ± 1/64"

### PESO DEL BORDE

Peso neto	13.23 lb
-----------	----------

### ⚠ ADVERTENCIA

Para evitar el riesgo de descargas eléctricas, lesiones personales o la muerte:

- Antes de perforar la pared, observe dónde están los tomacorrientes y donde podría estar el cable eléctrico oculto detrás de la pared. **PODRÍA RECIBIR UNA DESCARGA ELÉCTRICA si toca el cable eléctrico** con la mecha.
- Ubique y desconecte la alimentación de cualquier circuito eléctrico que podría verse afectado por la instalación de este horno.

**SI NO DESCONECTA LA ALIMENTACIÓN, PODRÍA RECIBIR UNA DESCARGA ELÉCTRICA.**

### ⚠ ADVERTENCIA

Para evitar una lesión física, use guantes cuando manipule las piezas metálicas. Las piezas son afiladas y pueden causar cortes y abrasiones.

## PASO 2

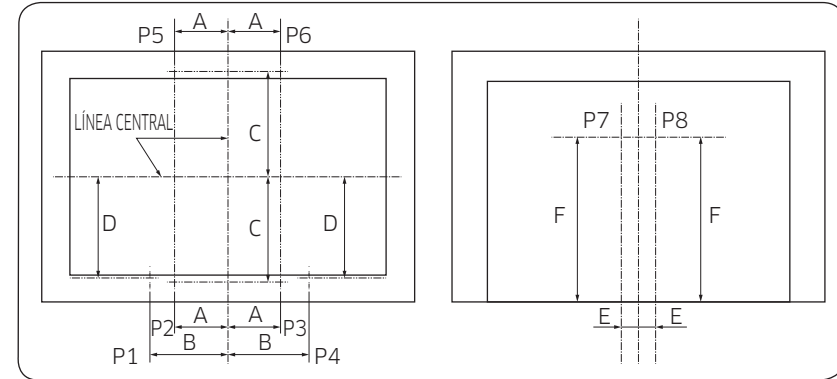

A : 5 1/8" (130 mm)

B : 6 7/8" (175 mm)

C : 9 3/8" (238.5 mm)

D : 8 23/32" (221.3 mm)

E : 7/8" (23 mm)

F : 16 1/8" (409.5 mm)

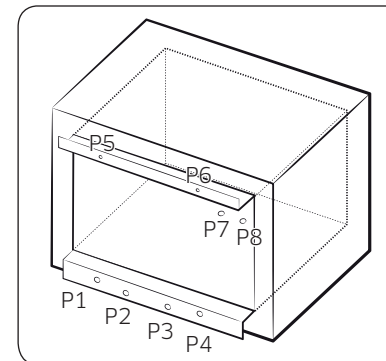

1. Pliegue la línea inferior de la plantilla de modo que coincida con la línea del borde del gabinete y marque 6 agujeros en la parte inferior. (P1,2,3,4,7,8)
2. Pliegue la línea superior de la plantilla de modo que coincida con la línea del borde del gabinete y marque 2 agujeros en la parte superior. (P5,6)
3. Luego perforo un agujero piloto en las ocho posiciones con una mecha de 7/64 o #35.

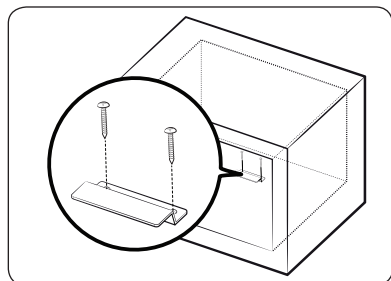

4. Ajuste 2 tornillos en el gancho de instalación; use los TORNILLOS A (2 uds.) provistos.

**NOTA**

Si la mecha es más gruesa, es posible que no pueda instalarlo.

**PASO 3**

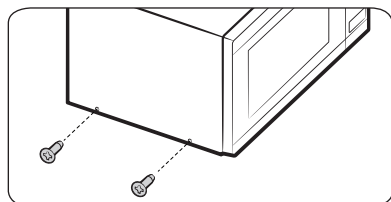

5. Quite 4 tornillos del lado inferior derecho e izquierdo del panel exterior.

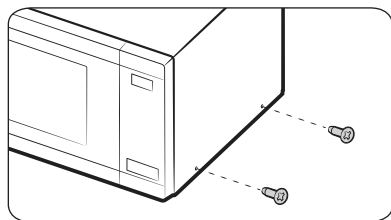

**PASO 4**

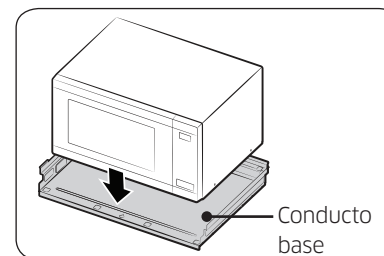

1. Coloque el horno en el conducto base.

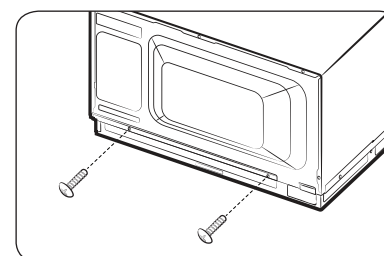

2. Ajuste 2 tornillos en el lado trasero con el conducto base; use los TORNILLOS C (2 uds.) provistos.

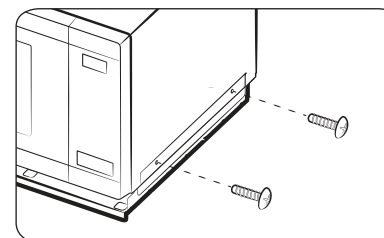

3. Ajuste 2 tornillos en el lado derecho con el conducto base; use los TORNILLOS C (2 uds.) provistos.

# Instalación

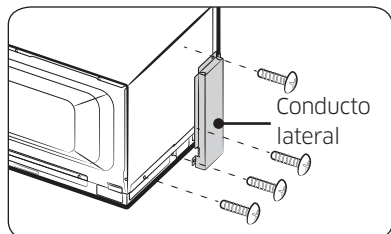

4. Ajuste 4 tornillos en el conducto base y el conducto lateral por el lado izquierdo; use los TORNILLOS C (4 uds.) provistos.

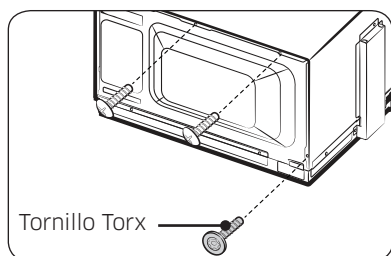

5. Quite 2 tornillos C de la parte superior trasera. Además, quite 1 tornillo Torx con el destornillador Torx de la parte inferior trasera. No deseche los tornillos (3 uds.).

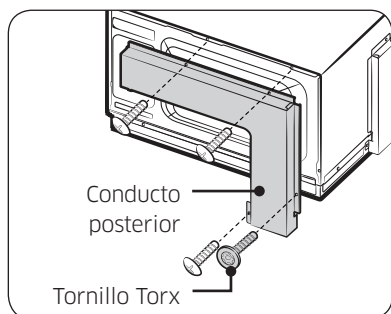

6. Ajuste un tornillo Torx y 3 tornillos C en la parte superior trasera.

## PASO 5

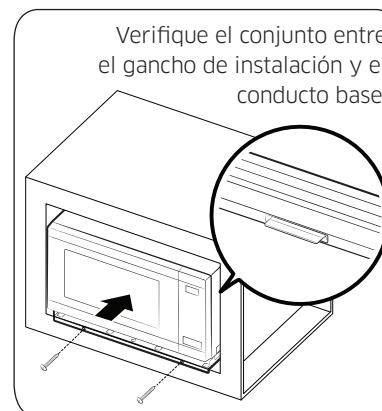

1. Deslice el horno con el conducto base hasta el gabinete hasta que el conducto base toque el frente del gabinete.
2. Enchufe el cable de alimentación en el tomacorriente.
3. Ajuste 2 tornillos en el conducto base y el gabinete; use los TORNILLOS A (2 uds.) provistos.

### NOTA

Tenga cuidado cuando coloque el horno en el gabinete ya que este puede moverse.

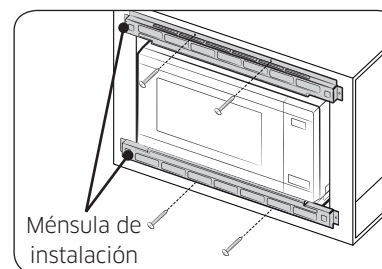
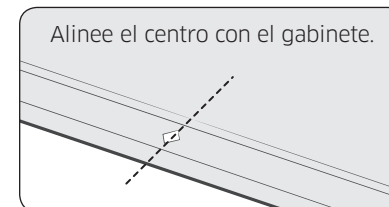

4. Después de colocar la ménsula de instalación de modo que coincida con los agujeros, ajuste ambos mediante los TORNILLOS A (4 uds.) provistos.

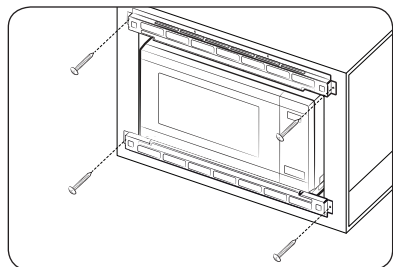

5. Ajuste los 4 agujeros de la ménsula de instalación; use los TORNILLOS A (4 uds.) provistos.

## STEP 6

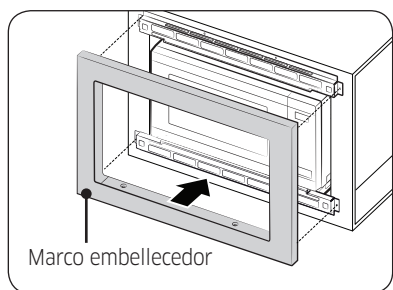

1. Presione el marco embellecedor en la abertura hasta que los lados encajen en su lugar.

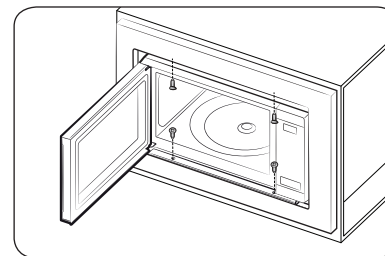
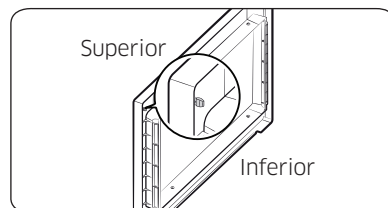

2. Abra la puerta del horno. Ajuste los 4 tornillos del marco embellecedor; use los TORNILLOS B (4 uds.) provistos.

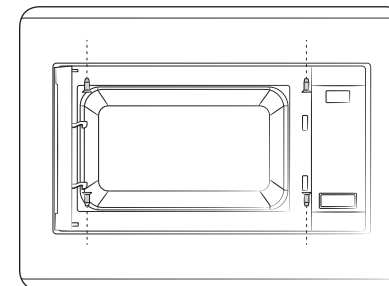
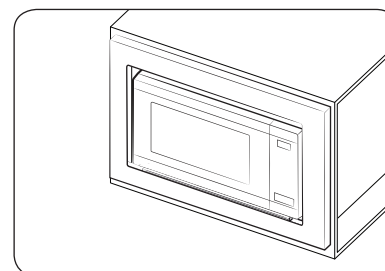

**SAMSUNG**



DE68-04476A-02