

# RADIANT COOKTOP 600 SERIES 36"



CODE ID

36" RADIANT COOKTOP WITH TOUCH CONTROL WITH BRUSHED ALUMINUM TRIM

**F6RT36S2**



Easy Clean Ceramic Glass



Slide Touch Control



Bridge Zone



Triple Radiant



Timer



Residual Heat Sensor



Frame Creative

## RADIANT COOKTOP

Digital Display for Power Level

Low Power Scale for Delicate Cooking

Control Display Lock

Automatic Fast Boil Function

Power and Hot surface Indication

Timer Functions

Timer Display

Acoustic Buzzer

Independent timer for each zone

Booster function for each cooking zone

Failure Codes Indication

# DISTINTO

36" RADIANT COOKTOP WITH TOUCH  
CONTROL WITH BRUSHED ALUMINUM TRIM

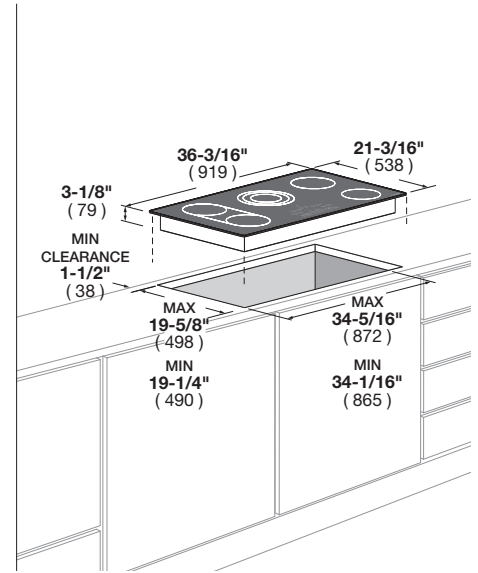

CODE ID		F6RT36S2 - 36" RADIANT COOKTOP WITH TOUCH CONTROL WITH BRUSHED ALUMINUM TRIM	
Series and Finish	600 Series - Ceramic glass with aluminum frame		
<b>CONTROL PANEL</b>			
Control Type	Touch Control		
<b>COOKTOP</b>			
Type	RADIANT		
Cooking Surface	Ceramic Glass		
<b>RADIANT COOKTOP FEATURES</b>			
Power Setting	Peacock Slider Touch Control		
Digital Display for Power Level	5		
Low Power Scale for Delicate Cooking	•		
Control Display Lock	•		
Automatic Fast Boil Function	•		
Hot Surface Indication	•		
Timer Functions	1+5		
Timer Display	•		
Acoustic Buzzer	•		
Failure Codes Indication	•		
Cooking Zones	5		
Burners types (Front/Rear-L) - Power	7"	(180 mm)	1800W
Bridge Element - Power			800W
Burners types (Central) - Power	9" / 7" / 5"	(230 mm / 180 mm / 127 mm)	2500W / 1600W / 800W
Burners types (Rear-R) - Power	7"	(180 mm)	1800W
Burners types (Front-R) - Power	6"	(153 mm)	1200W
<b>DIMENSIONS/WEIGHT</b>			
Overall dim - Width	36 - 3/16"	(919 mm)	
Overall dim - Height	3 - 5/16" + conduit 15/16"	(84 mm) + conduit (24 mm)	
Overall dim - Depth	21 - 3/16"	(538 mm)	
Cut-out - Width (min - max)	34 - 1/16", 34 - 5/16"	(865 mm) - (872 mm)	
Box - Height	3 - 1/16" + conduit 15/16"	(78 mm) + conduit (24 mm)	
Cut-out - Depth (min - max)	19 - 1/4", 19 - 5/8"	(490 mm) - (498 mm)	
Gross Weight	44 lbs	(20 kg)	
<b>POWER / RATINGS (208/240 V, 60 HZ)</b>			
kW / Amps rating at 240V, 60Hz	9.90kW - 41.3A		
kW / Amps rating at 208V, 60Hz	7.44kW - 35.8A		
Power Cable	Conduit		
<b>INSTRUCTIONS FOR USE</b>			
Use & Care Manual / Installation Manual	English / French / Spanish		