

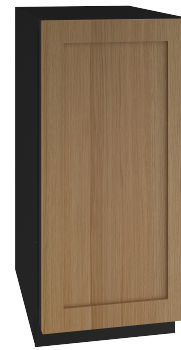

Stainless Solid



Integrated Solid

Key Features

- **Industry Exclusive: U-Choose™ feature offers five levels of ice density**
- **Industry Exclusive: Interior water dispenser**
- **Industry Leading: Produces up to 90 lb of ice per day**
- **Industry Leading: Stores 30 lb of ice**
- Makes cylindrical compressed ice bits approx. 3/4" L x 1/2" H
- Eco friendly - most efficient type of specialty ice
- Adjustable bright white or blue LED lighting
- Soft close door with articulating hinge
- Black interior
- Digital touch pad control with blue LED display
- Indicator alert notifies user when cleaning is needed
- Stainless steel handle (7/8" diameter)
- Easiest nugget ice machine cleaning process in the industry
- Integrated model requires 3/4" custom door panel and handle (not supplied by U-Line)
- Field reversible door is shipped right-hand hinged
- Built-in or freestanding
- Four adjustable leveling legs
- Factory installed drain pump model recommended if a gravity drain is not accessible

Model Details

Model	Voltage/Hz	Door Swing	Pump	Finish	Shipping Weight
UHNB315-SS01A	115 / 60	Field Reversible	-	Stainless Solid	107 lb
UHNP315-SS01A	115 / 60	Field Reversible	Pump Included	Stainless Solid	112 lb
UHNB315-IS01A	115 / 60	Field Reversible	-	Integrated Solid	102 lb
UHNP315-IS01A	115 / 60	Field Reversible	Pump Included	Integrated Solid	107 lb

Accessories

Model	Description	Finish	Shipping Weight
80-55266-00	Nugget Ice Cleaner (Single 8 oz. bottle)	N/A	1 lb
80-55268-00	Replacement Water Filter (3 Class Nugget Ice)	N/A	2 lb

Dimensions

Front

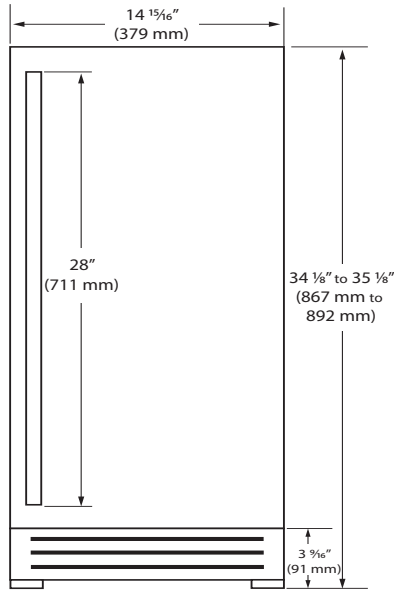

Side

*Add 1/2" for Integrated models with 3/4" integrated panel installed.

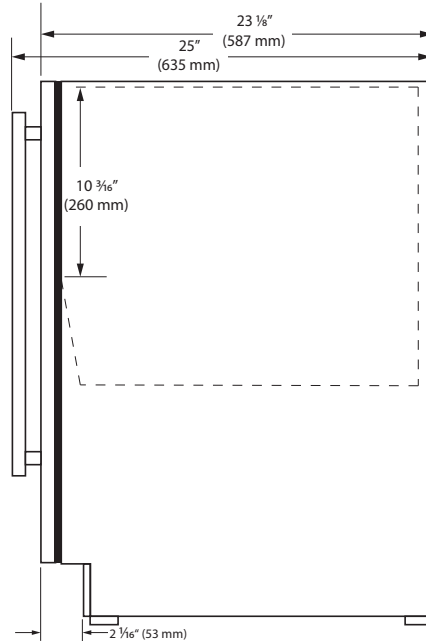

Top

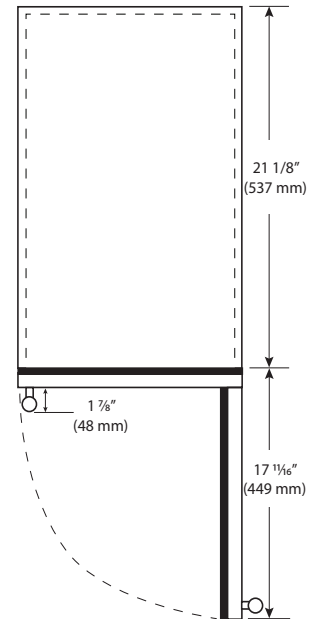

Specifications

Model	HNB315
Amps: Running	3
Dimensions: Product Depth*	23 1/8" / 587 mm
Dimensions: Product Height	34 1/8" / 867 mm
Dimensions: Product Width	14 15/16" / 379 mm
ENERGY STAR	Yes
Ice Production Per Day	90 lb
Ice Storage	30 lb
Panel Height	30"
Panel Thickness	3/4" (20mm)
Panel Type	Solid Panel
Panel Width	15"
Product Weight: Max	112 lb
Refrigerant Type:	R600a
Sabbath (Star K Certified)	Yes

Back

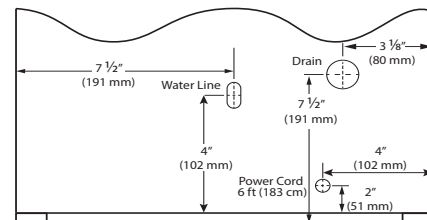

Cabinet Cut-Out

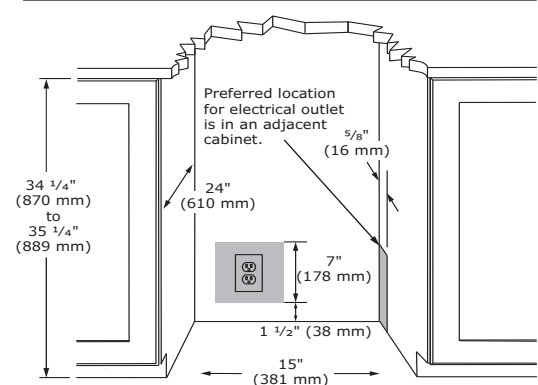

Warranty

- 1 Year (parts & labor) / 5 year sealed system (parts)
- **2 Year (parts & labor) / 5 year sealed system (parts) upgrade at no cost with product registration**



See complete warranty for details

Installation Notes

- No additional clearance is needed for ventilation
- Do not obstruct front grille air flow



Please visit u-line.com to view this model's User Guide & Service Manual. All Specifications are subject to change without notice.