

ASSEMBLY INSTRUCTIONS



Fine Furniture for every stage of life

305877Q (B1&B2)
Queen Bed

ITEM: 305877Q (B1&B2)



ASSEMBLY INSTRUCTIONS

ASSEMBLY TIPS:

1. Remove hardware from box and sort by size.
2. Please check to see that all hardware and parts are present prior to start of assembly.
3. Please follow attached instructions in the same sequence as numbered to assure fast & easy assembly.



WARNING!

1. Don't attempt to repair or modify parts that are broken or defective. Please contact the store immediately.
2. This product is for home use only and not intended for commercial establishments.











ASSEMBLY TIME

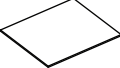



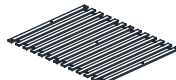

30 MINUTES

PARTS IDENTIFICATION

B1 (BOX 1)

A	HEADBOARD PANEL		1PC	F	DRAWER RIGHT SIDE PANEL (WITH "F" LABEL)		4PCS
B	LEFT HEADBOARD LEG (WITH "L" LABEL)		1PC	G	BOTTOM PANEL		4PCS
C	RIGHT HEADBOARD LEG (WITH "R" LABEL)		1PC	H	DRAWER SUPPORT		8PCS
D	DRAWER BACK PANEL (WITH "D" LABEL)		4PCS	I	CASTER WITH SCREW		16SETS
E	DRAWER LEFT SIDE PANEL (WITH "E" LABEL)		4PCS	J	ROLL SLAT (13pcs)		1SET

B2 (BOX 2)

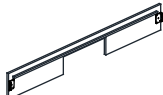
K	DRAWER FRONT PANEL		4PCS	O	BED RAIL SUPPORT LEG		4PCS
L	FOOTBOARD FRAME		1PC	P	CENTER RAIL		1PC
M	FOOTBOARD LEG		2PCS	Q	CENTER RAIL SUPPORT WITH LEVELER		3PCS
N	BED RAIL		2PCS				

NOTE:

Phillips head screw driver is required in the assembly process; however, manufacturer does not provided this item.

ITEM: 305877Q (B1&B2)



ASSEMBLY TIPS:

1. Remove hardware from box and sort by size.
2. Please check to see that all hardware and parts are present prior to start of assembly.
3. Please follow attached instructions in the same sequence as numbered to assure fast & easy assembly.







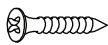

WARNING!

1. Don't attempt to repair or modify parts that are broken or defective. Please contact the store immediately.
2. This product is for home use only and not intended for commercial establishments.

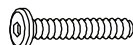
HARDWARE IDENTIFICATION

Z-B2 (BOX 2) - HARDWARE PACK IS LOCATED IN 305877Q (B2)

1	SHORT BOLT (M8 x 20MM - RBW)		8PCS	6	FLAT HEAD SCREW (M4 x 32MM - RBW)		38PCS
2	MEDIUM BOLT (M6 x 35MM - RBW)		16PCS	7	WOOD DOWEL (M8 x 30MM)		64PCS
3	LONG BOLT (M6 x 50MM - RBW)		11PCS	8	SMALL ALLEN WRENCH (M4 x 65MM - BLK)		1PC
4	LOCK WASHER (15/64" X 13 Ø - RBW)		14PCS	9	BIG ALLEN WRENCH (M5 x 65MM - BLK)		1PC
5	FLAT WASHER (15/64" X 19 Ø - RBW)		14PCS				

NOTE:

Phillips head screw driver is required in the assembly process; however, manufacturer does not provided this item.

ITEM: 305877Q (B1&B2)

ASSEMBLY INSTRUCTIONS

STEP 1

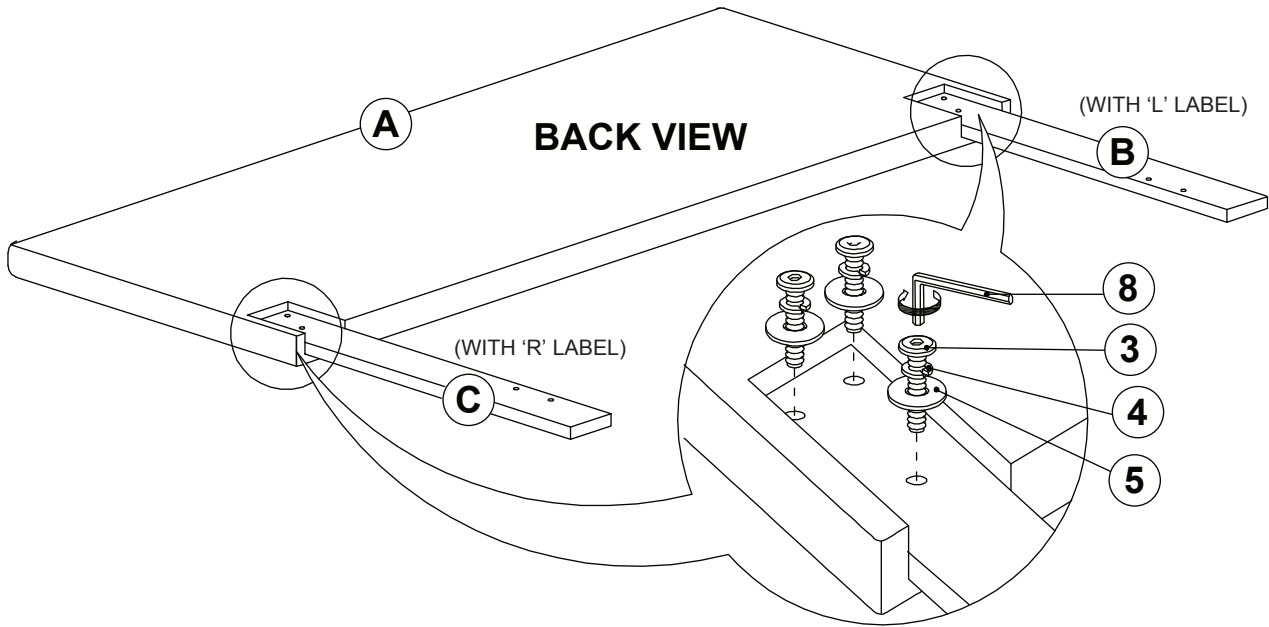

STEP 2

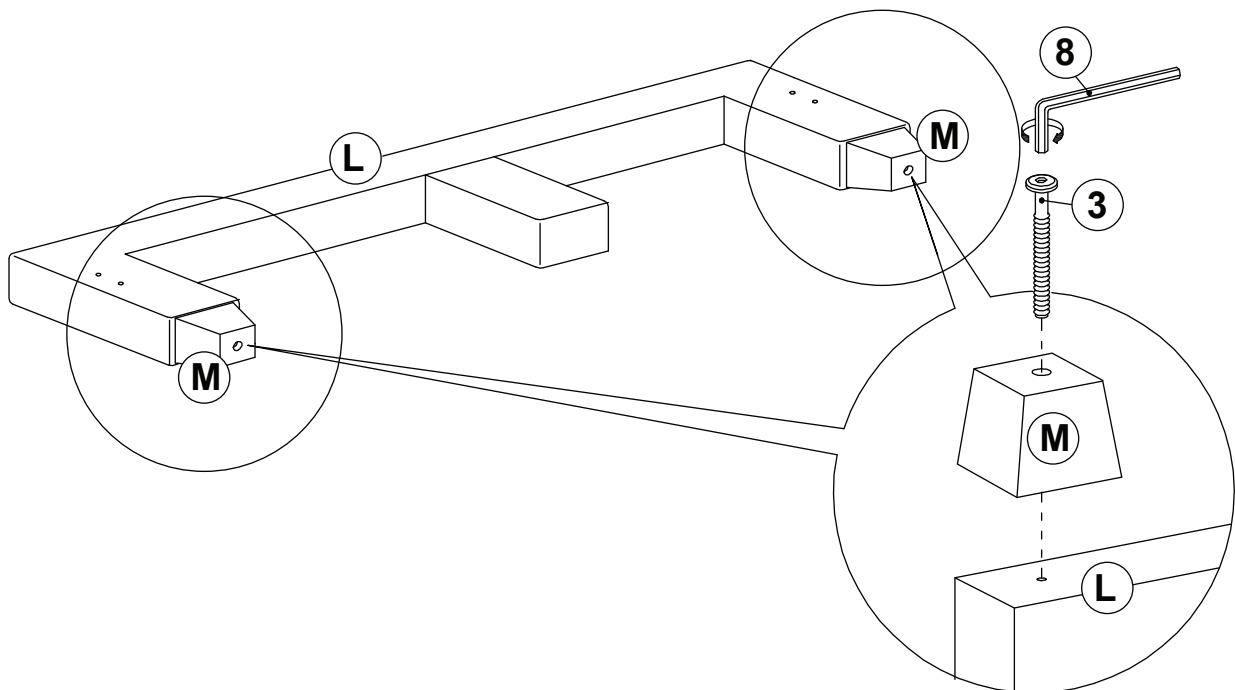

ITEM: 305877Q (B1&B2)

ASSEMBLY INSTRUCTIONS

STEP 3

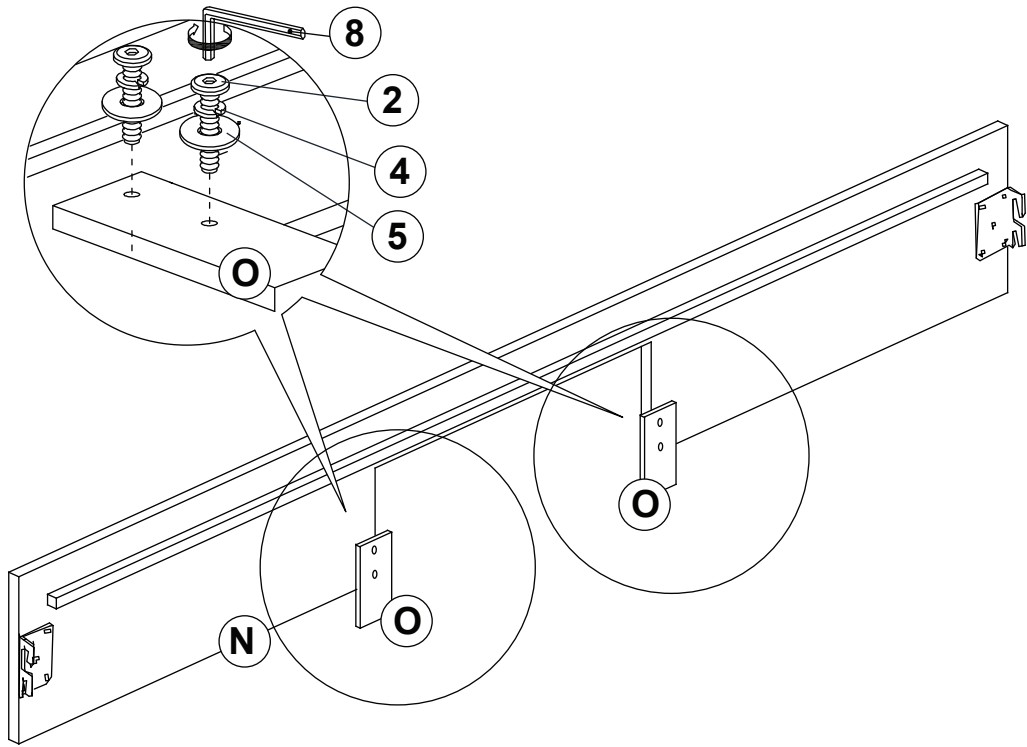

STEP 4

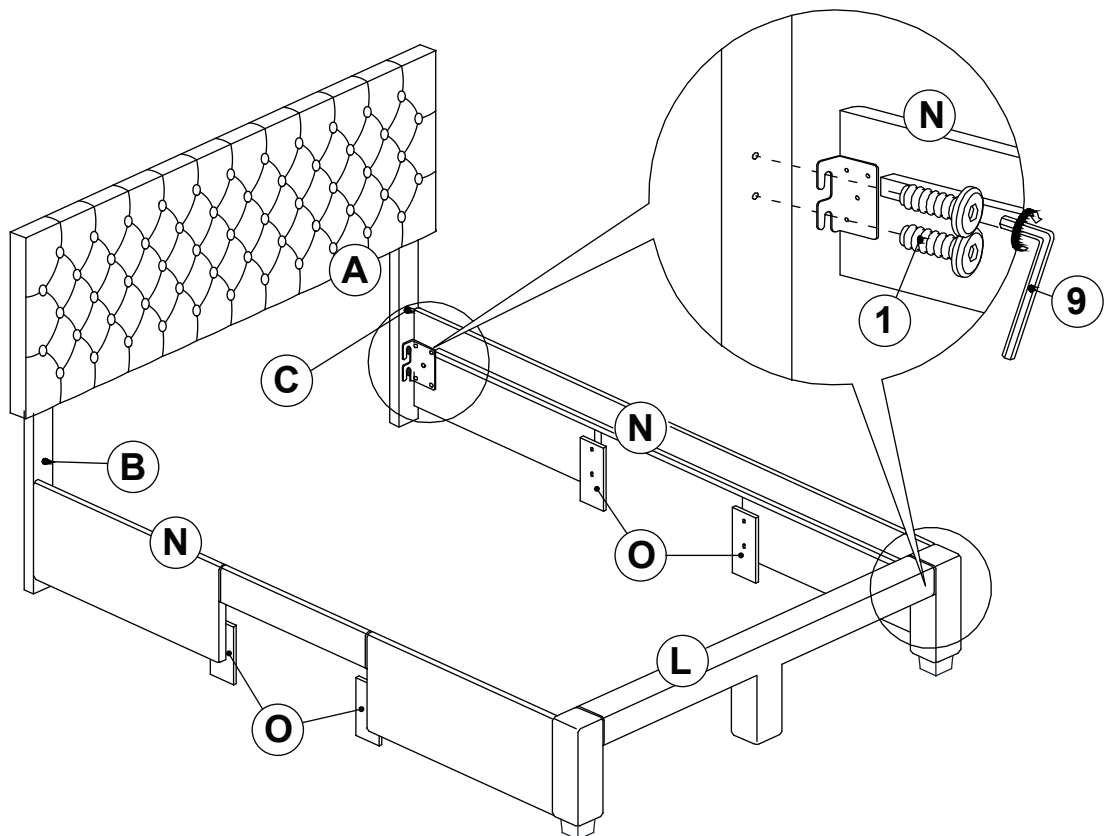

ITEM: **305877Q (B1&B2)**



ASSEMBLY INSTRUCTIONS

STEP 5

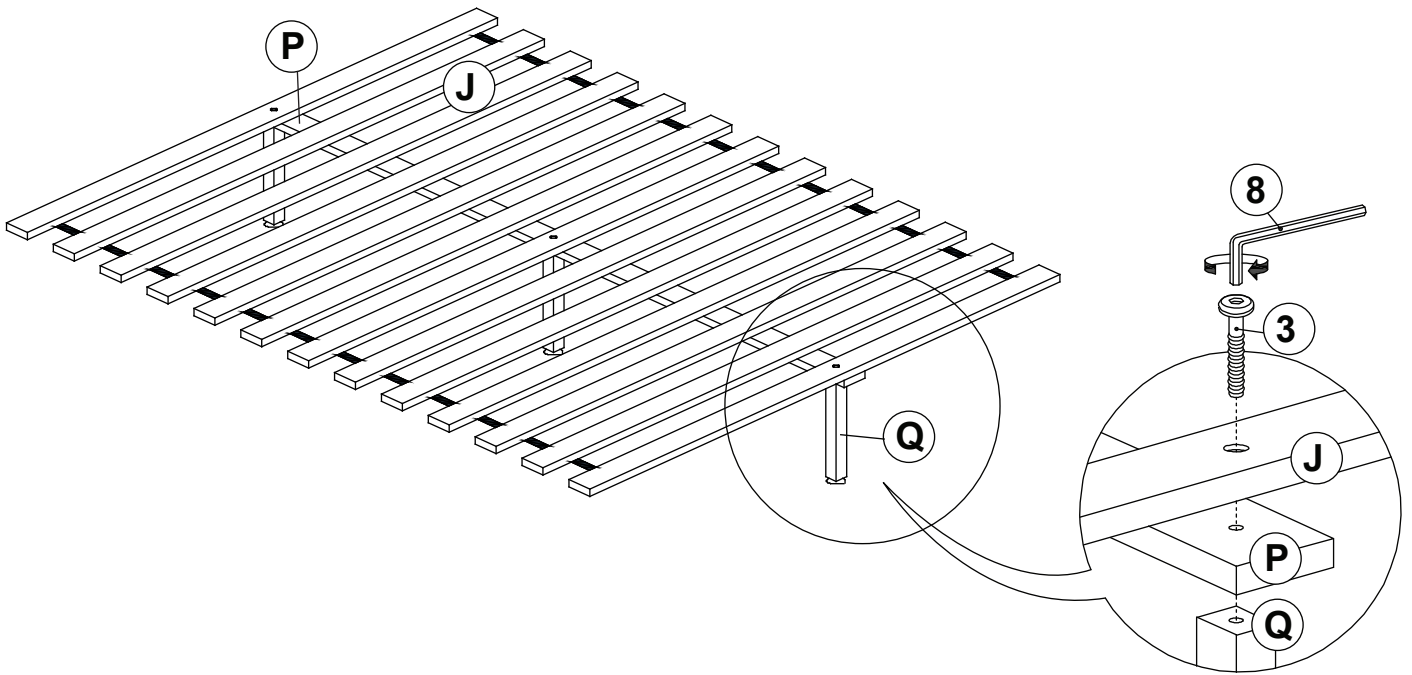

STEP 6

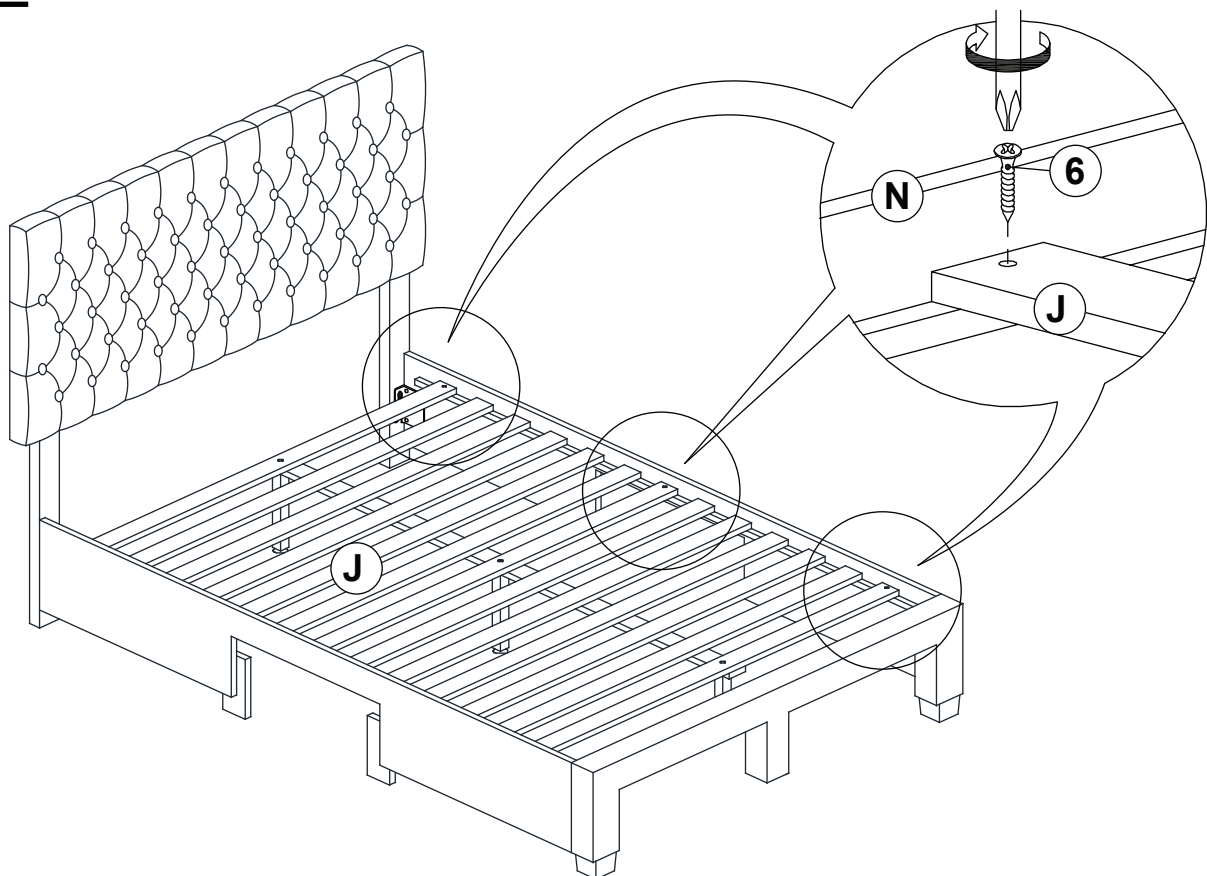

ASSEMBLY INSTRUCTIONS

STEP 7

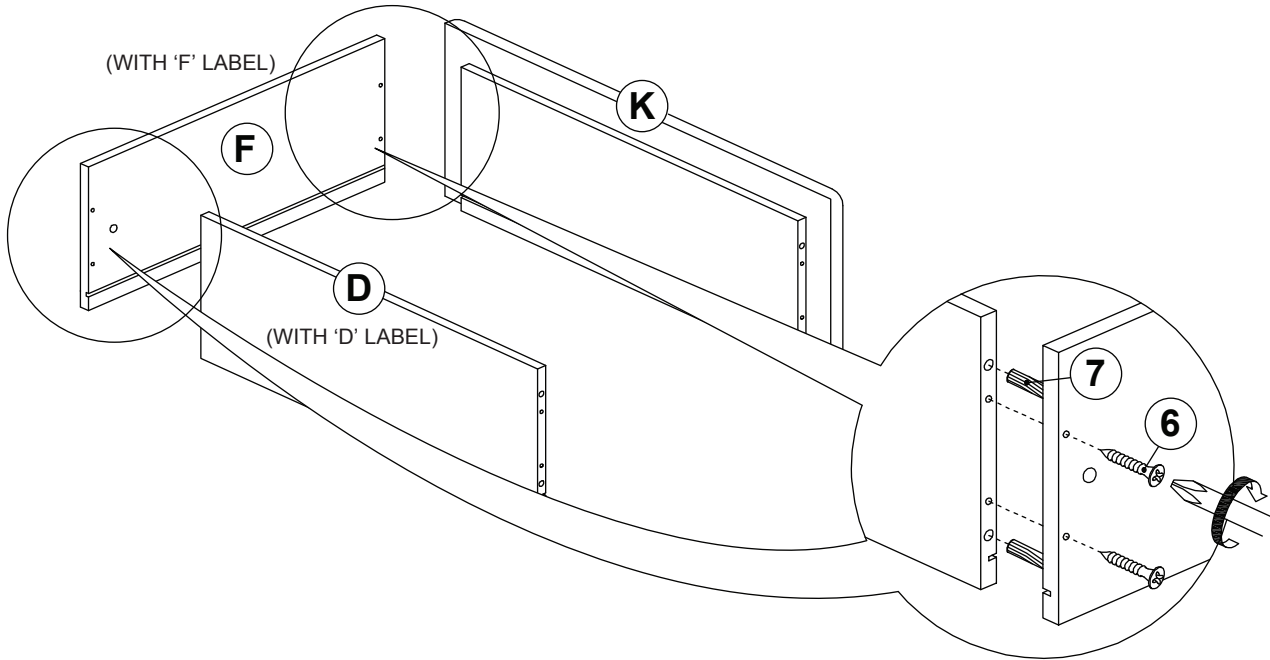

STEP 8

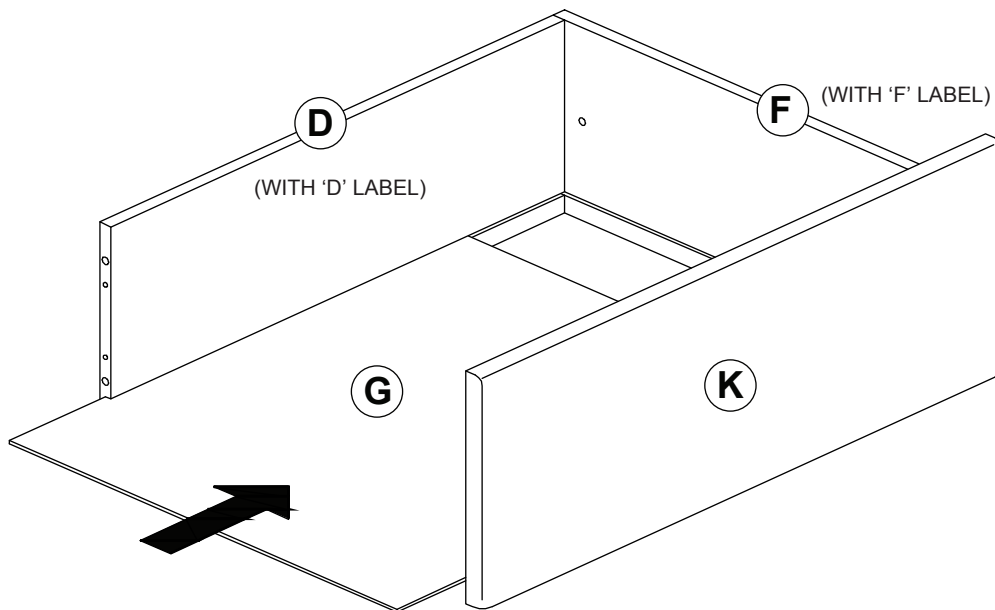

ITEM: 305877Q (B1&B2)

ASSEMBLY INSTRUCTIONS

STEP 9

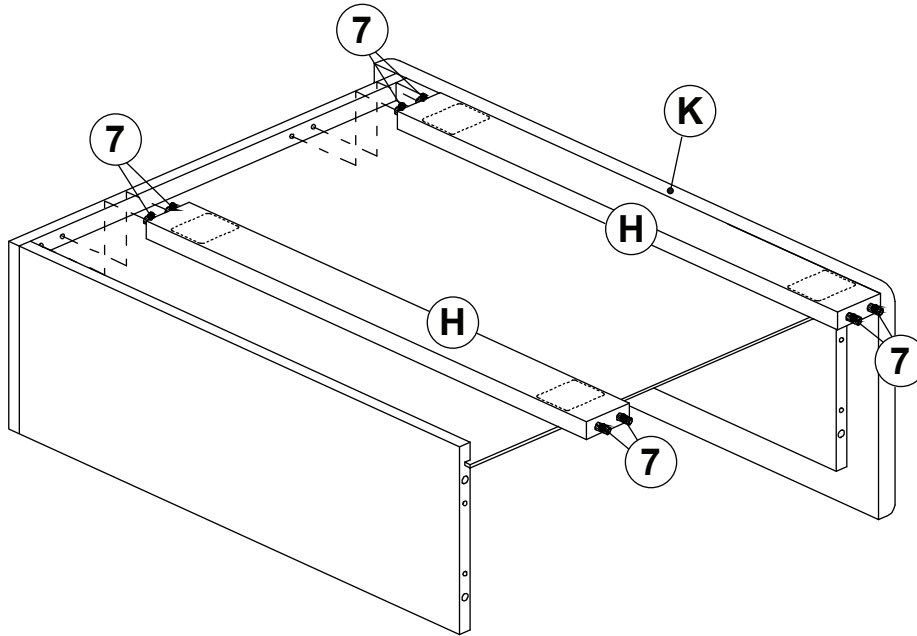

STEP 10

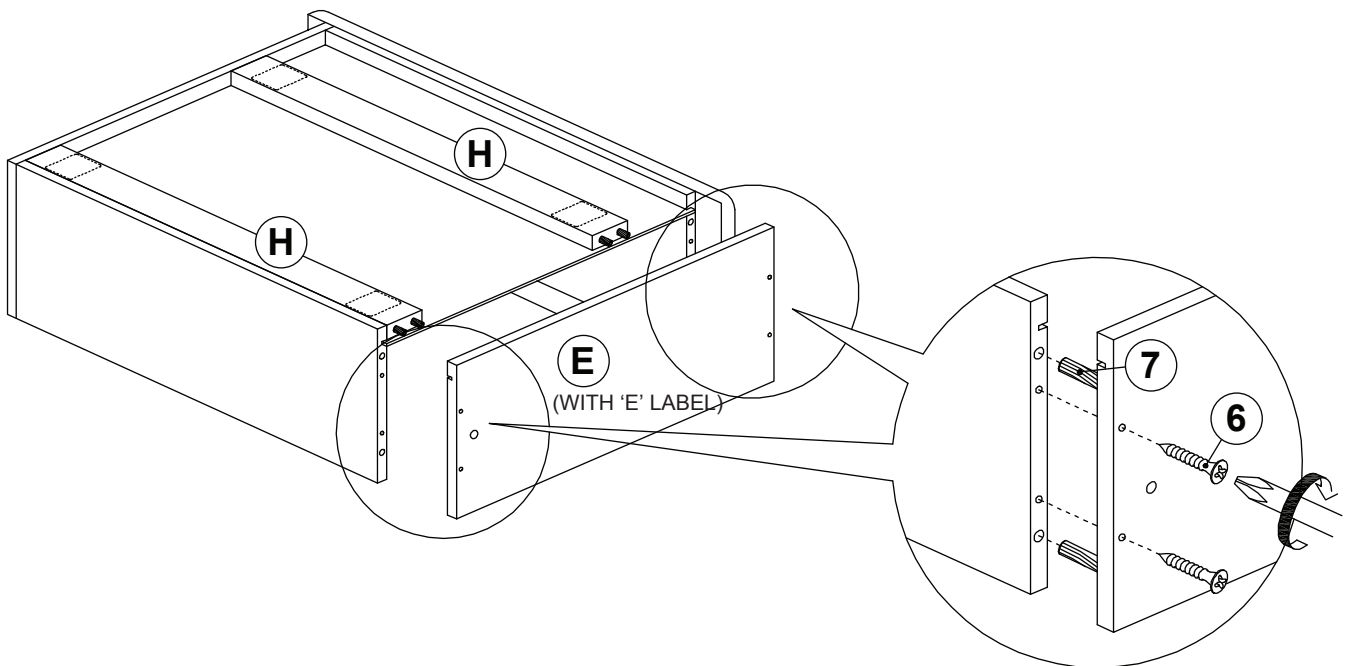

ITEM: **305877Q (B1&B2)**

ASSEMBLY INSTRUCTIONS

STEP 11

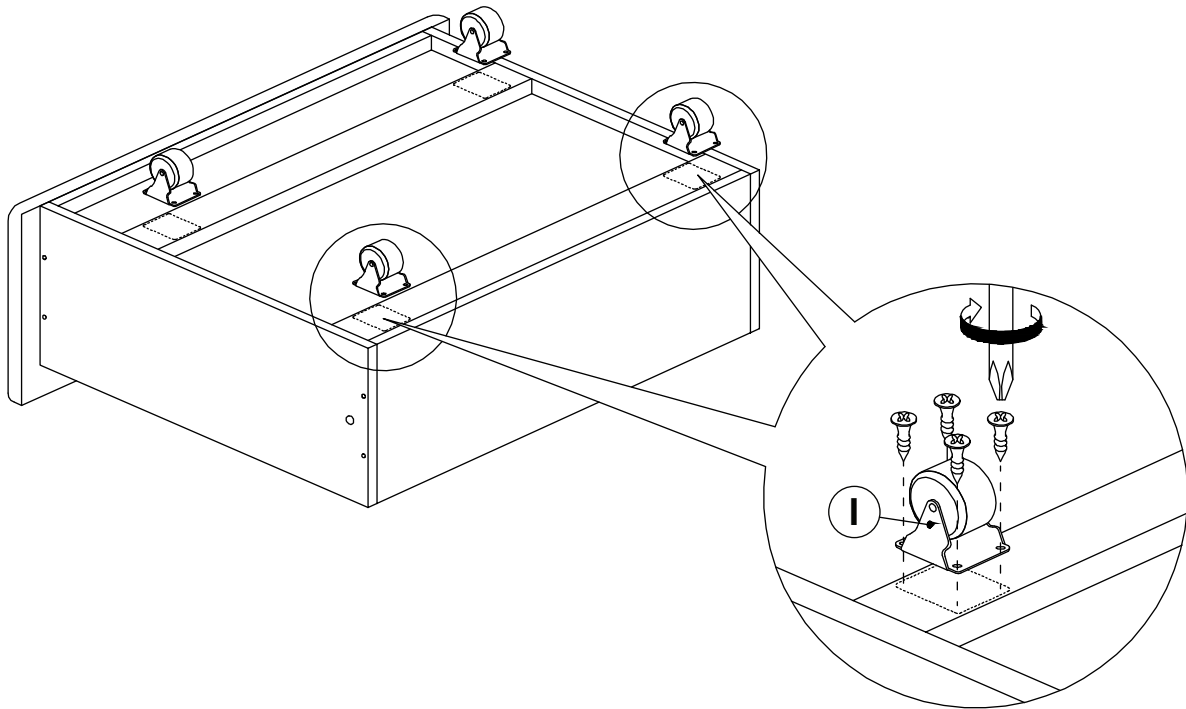

STEP 12

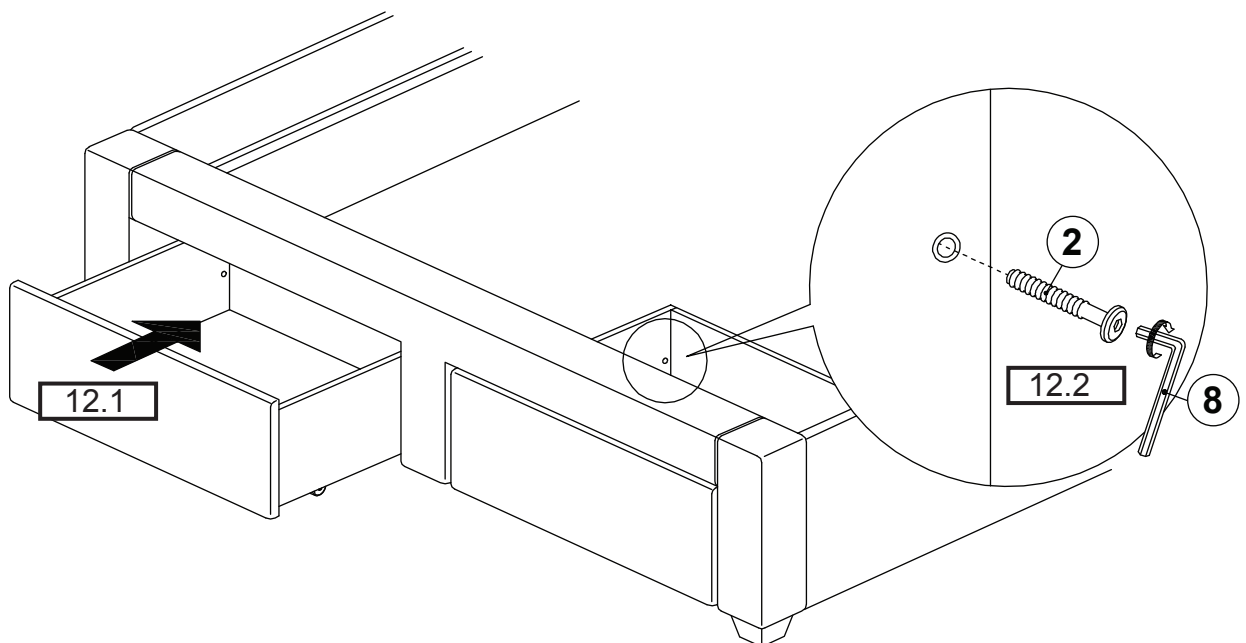

ITEM: **305877Q (B1&B2)**



ASSEMBLY INSTRUCTIONS

STEP 13

COMPLETE

