

USER MANUAL

COFFEE GRINDER

EN

MANUEL DE L'UTILISATEUR

MOULIN À CAFÉ

FR

MANUAL DE USO

MOLINILLO DE CAFÉ

ES



We advise you to read this manual carefully, as it contains all the instructions for managing the appliance's aesthetic and functional qualities.

For further information on the product: www.smegusa.com

Nous conseillons de lire attentivement ce manuel, qui comprend toutes les indications pour maintenir inchangées les qualités esthétiques et fonctionnelles de l'appareil acheté.

Pour obtenir des informations supplémentaires sur le produit : www.smegusa.com

Aconsejamos leer atentamente este manual que contienen todas las indicaciones para mantener inalterada la calidad estética y funcional del aparato adquirido.

Más información sobre el producto en: www.smegusa.com

"A"

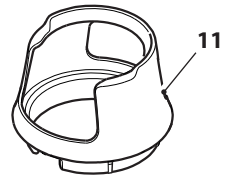
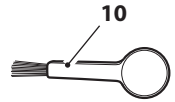
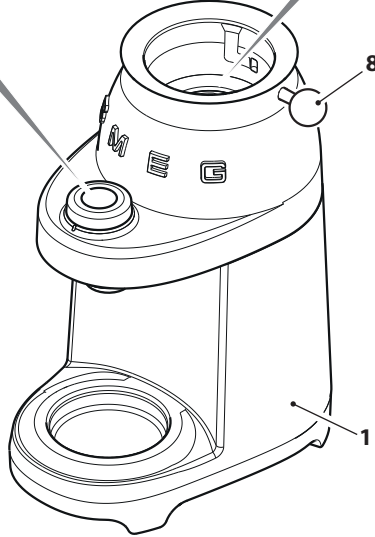
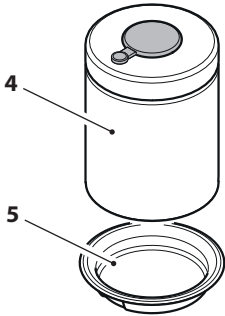
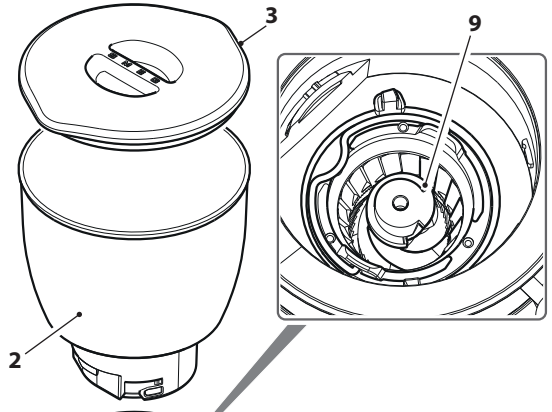
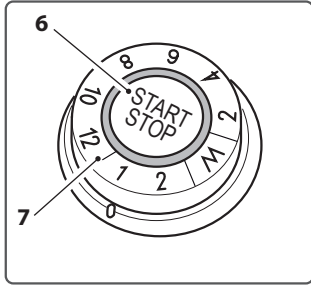

"B"

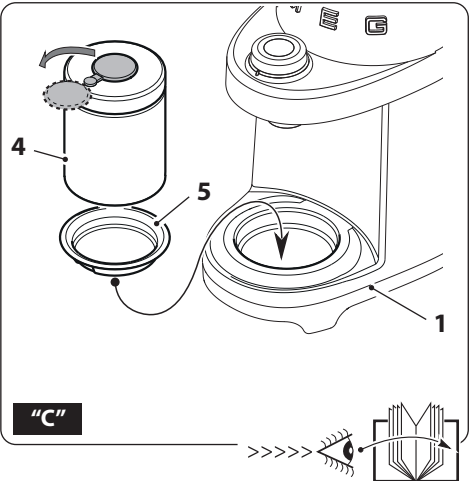
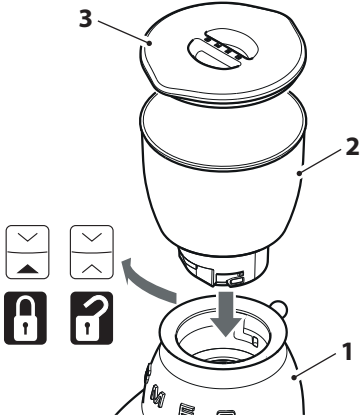

"C"

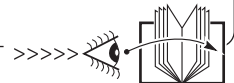

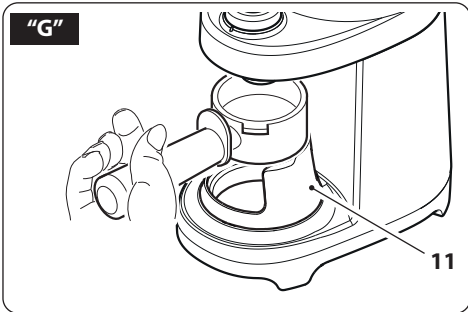
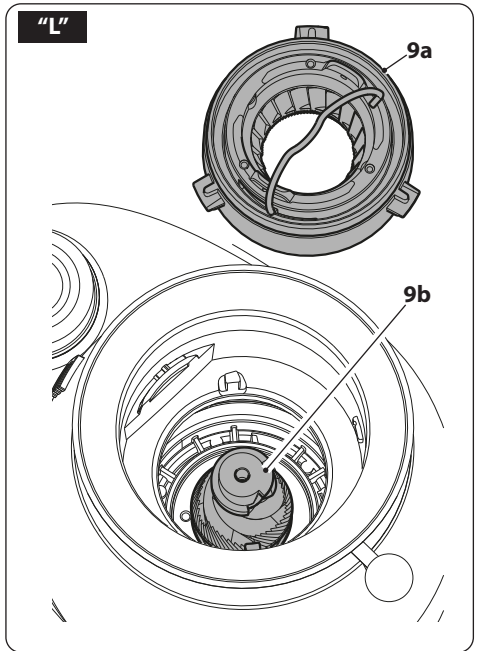
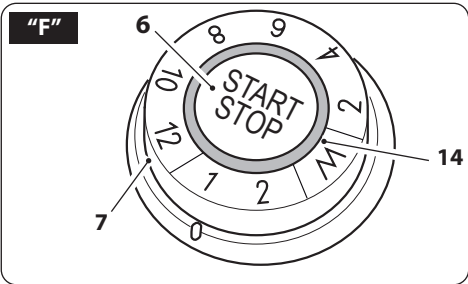
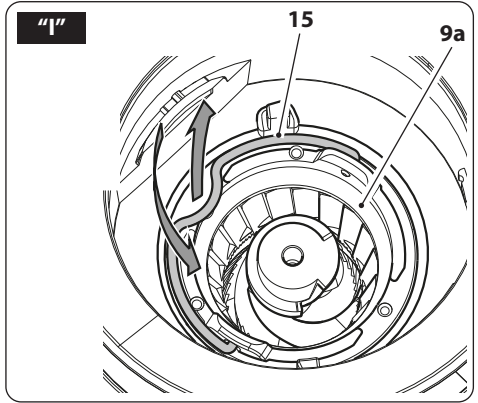
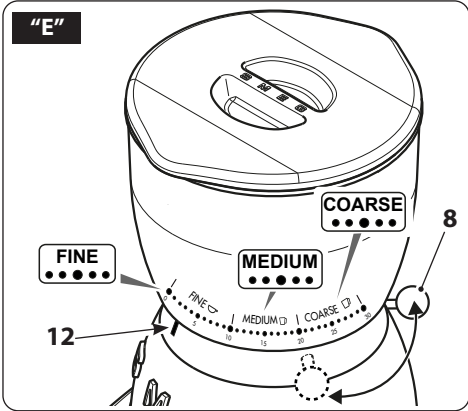
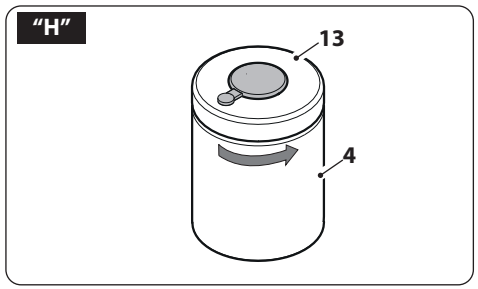
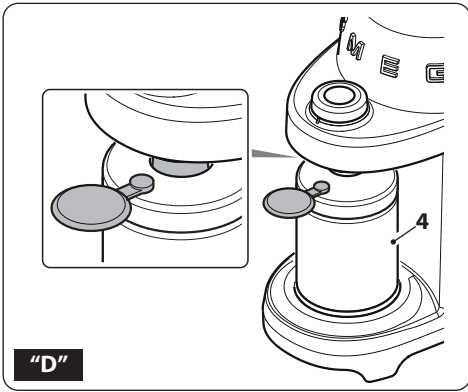

**Important information for the user
Informations importantes pour l'utilisateur
Información importante para el usuario**

 **Instructions / Instructions / Instrucciones**

 **Description / Description / Descripción**

 **Use / Utilisation / Uso**

 **Cleaning and care / Nettoyage et entretien / Limpieza y cuidado**

 **Safety instructions / Consignes de sécurité / Instrucciones de seguridad**

 **Information / Informations / Información**

 **Advice / Conseil / Recomendaciones**

The manufacturer reserves the right to make any changes deemed useful for the improvement of its products without prior notice. The illustrations and descriptions contained in this manual are therefore not binding and are merely indicative.

Le fabricant se réserve la faculté d'apporter, sans préavis, toutes les modifications qu'il jugera utiles pour l'amélioration de ses produits. Les illustrations et les descriptions figurant dans ce manuel ne sont pas contraignantes et n'ont qu'une valeur indicative.

El fabricante se reserva el derecho a aportar sin aviso previo todas las modificaciones que considere útiles para la mejora de sus propios productos. Las ilustraciones y las descripciones contenidas en este manual no comprometen, por tanto, al fabricante y tienen un valor meramente indicativo.



Important instructions

Important instructions



WARNING: If the instructions contained in this manual are not followed precisely, fire or explosion may result causing property damage, personal injury or death.



READ AND SAVE THESE INSTRUCTIONS

Your safety and the safety of others are very important.

We have provided many important safety messages throughout this manual and on the appliance.

Read all the instructions before using the appliance and always obey all safety messages.

WARNING



- To reduce the risk of fire or electric shock, do not remove the cover (or back).
- No user-serviceable parts inside!
- Repair should be done by authorized service personnel only.



RECOGNIZE SAFETY INFORMATION

This is a safety alert symbol. This symbol alerts you to potential hazards that can result in severe personal injury or death.

UNDERSTAND SIGNAL WORDS

A signal word - DANGER, WARNING or CAUTION - is used with the safety alert symbol. DANGER denotes the most serious hazards. It means you could be killed or seriously injured if you do not immediately follow the instructions.

WARNING means you could be killed or seriously injured if the instructions are not followed. CAUTION indicates a potentially hazardous situation, which, if not avoided, could result in minor to moderate injury.

Important instructions



ATTENTION



- This appliance is intended for use in the home only.
- Use this appliance only for its intended purpose. The manufacturer cannot be held liable for damage caused by improper use of this appliance.
- This appliance complies with current safety regulations. Improper use of this appliance can result in personal injury and material damage.
- Read all the instructions before installing or using the appliance for the first time.
- Keep these operating instructions in a safe place and pass them on to any future user.

The safety messages will inform you of potential hazards, on how to avoid the risk of injury and what can occur if the instructions are not followed.

IMPORTANT: Observe all codes and ordinances in force.

WARNING: For your safety, the instructions contained in this manual must be followed to minimize the risk of fire or explosion and to prevent property damage, personal injury or death.

Do not store or use gasoline or other flammable vapors, liquids or materials near this or any other appliance.



NOTE: This appliance is NOT designed for installation in manufactured (mobile) homes or in recreational vehicles (RVs).



NOTE:

POLARIZED PLUG (for product manufactured with polarized plug)

This appliance has a polarized plug (one blade is wider than the other). To reduce the risk of electric shock, this plug is designed to fit into a polarized outlet only one way. If the plug does not fit fully into the outlet, flip it over and try again. If it still does not fit, contact a qualified electrician. Do not modify the plug in any way.

GROUNDING PLUG (for product manufactured with a grounded plug)

As a safety feature, this product is equipped with grounded plug, which will only fit into a three-prong outlet. Do not attempt to bypass this safety feature. Improper connection of the grounding conductor may result in the risk of electric shock. Consult a qualified electrician if you have any doubts on whether the outlet is properly grounded.



Important Safeguards

WARNING When using electrical appliances, basic safety precautions should always be followed to reduce the risk of fire, electric shock, and / or injury to person including the following:



Follow all safety precautions to ensure safe use of the appliance.

- Before using the appliance, read this user manual carefully.
- Do not use the appliance outdoors.
- This appliance is for household use only.
- Do not use the appliance for other than its intended use.
- Do not allow children to use the appliance.
- Children should not play with the appliance. Keep the appliance out of the reach of children.
- Keep the packaging material (plastic bags, expanded polystyrene) out of the reach of children.
- Close supervision is necessary when any appliance is used by or near children.
- Turn off the appliance immediately after use.
- Do not leave the appliance unattended while it is running.
- Disconnect the appliance from the wall outlet before assembly, disassembly, cleaning and after each use.
- To disconnect, turn any control to the off position, then remove plug from wall outlet.
- Unplug from outlet when the appliance is not in use, and before cleaning. Allow to cool before putting on or taking off parts, and before cleaning the appliance.
- Do not use appliance for other than intended use.
- To protect against fire, electrical shock and personal injury, do not immerse the appliance, the power cord or plug in water or any other liquid.
- Do not touch the appliance or the plug with wet hands.
- Never try to extinguish a flame/fire with water: turn off the appliance, unplug it from the outlet and cover the flame with a lid or a fire blanket.
- Do not use the appliance if the power cord or plug is damaged or if the appliance has been dropped or damaged in any way.
- Do not let cord hang over edge of table or counter, or touch hot surfaces.
- Do not operate any appliance with a damaged cord or plug or after the appliance malfunctions, or has been damaged in any manner. Return appliance to an authorized service facility for examination, repair or adjustment.
- Make sure the power cord does not come in contact with sharp edges.
- Do not pull on the cord to remove the plug from the socket.
- Do not place the appliance on or near switched-on gas or electric burners, inside an oven, or near heat sources.

SAVE THESE INSTRUCTIONS

Important Safeguards



- Do not touch hot surfaces. Use handles and knobs.
- Do not place the appliance near faucets or sinks.
- Never attempt to repair the appliance yourself or without the help of a qualified technician. Failing to do this will void the warranty.
- In case of malfunction, have the appliance repaired by a qualified technician.
- Do not make any changes to the appliance.
- Make sure that the power outlet used is always freely accessible, because only in this way can it be unplugged when necessary.
- To remove the plug from the power outlet, operate directly on the plug. Never pull the cable, it could be damaged.
- If the appliance should break down, do not attempt to repair it.
- Do not allow the power supply cable to dangle over the edge of the table or other surface or to touch hot surfaces.
- If the plug or power supply cable are damaged, have them replaced exclusively by the Technical After-sales centre, so as to prevent all risks.

For this appliance

- Do not use the appliance for more than 90 seconds consecutively. Leave the appliance to cool down for a few minutes before using it again.
- The appliance shall not be placed in a cabinet when in use.
- Leave a space of 10 cm around the appliance.
- Make sure the lid is firmly closed.
- Do not open the lid during the grinding.
- Do not use the appliance in combination with parts or accessories from other manufacturers.
- Use only original spare parts from the manufacturer. The use of spare parts not recommended by the manufacturer may cause fire, electric shock or injury to persons.
- Place the appliance on a flat, dry surface.
- Avoid wetting or spraying liquid on the appliance. In case of contact with liquid, immediately unplug the cord from the electrical outlet and dry thoroughly: Risk of electric shock!
- Do not use abrasive cleaners or sharp objects to clean the appliance.
- The use of an accessory not evaluated for use with this appliance may cause injuries.
- Do not install the appliance in an environment that is not suitable.
- Do not place the appliance on or in proximity of electric or gas cookers, or in a heated oven.

SAVE THESE INSTRUCTIONS



Important Safeguards

- Verify that there are no foreign objects inside the coffee grinder.
- This appliance is not intended for use by persons (including children) with reduced physical, sensory, or mental capabilities, or lack of experience and knowledge, unless they are closely supervised and instructed concerning use of the appliance by a person responsible for their safety. Children should be supervised to ensure that they do not play with the appliance.
- Avoid contacting moving parts.
- Check hopper for presence of foreign objects before using.
- This appliance has important markings on the plug blade. Contact a qualified technician to replace the plug with a suitable one if damaged.
- Connect the appliance only to a power outlet installed perfectly.
- Do not attempt to defeat any safety interlock mechanisms.

Electrical Cord:

- a) A short power-supply cord (or detachable power-supply cord) is provided to reduce risks resulting from becoming entangled in or tripping over a longer cord.
- b) Longer detachable power-supply cords or extension cords are available and may be used if care is exercised in their use.
- c) If a long detachable power-supply cord or extension cord is used:
 1. The marked electrical rating of the detachable power-supply cord or extension cord should be at least as great as the electrical rating of the appliance;
 2. If the appliance is of the grounded type, the extension cord should be a grounding-type 3-wire cord; and
 3. The longer cord should be arranged so that it will not drape over the counter top or table top where it can be pulled on by children or tripped over.

Connect the appliance

Make sure that the mains voltage corresponds with that indicated on the data plate on the bottom of the appliance.

Connect the appliance only to a power outlet installed perfectly.

If the plug and power outlet are incompatible, have the power outlet replaced with a suitable type by qualified staff.

SAVE THESE INSTRUCTIONS

Important Instructions



This user's manual

This user's manual is an integral part of the appliance and must be kept intact and available to the user throughout its life cycle.

Use compliant with destination

This appliance is intended for domestic use only.

Manufacturer's liability

The manufacturer declines all liability for damage undergone by persons and objects due to:

- use of the appliance different from that envisioned;
- user manual has not been read;
- tampering of individual parts of the appliance;
- use of non-original spare parts;
- failure to comply with safety recommendations.

Identification plate

The identification plate lists the technical data, serial number and brand name. The identification plate must never be removed.

Disposal



Power voltage
Risk of electric shock

- Unplug the appliance.
- Unplug the cord from the wall outlet.

• Old electrical equipment must not be disposed of with household waste!

In accordance with the law in force, electrical appliances at the end of their life should be taken to separate collection facilities for electrical and electronic waste. This is so that valuable materials from old appliances can be recycled and the environment can be protected. For more information, please contact your local authorities or recycling center employees.

Note that non-polluting and recyclable materials are used for packaging the appliance.

- Dispose of the packaging materials at appropriate differentiated waste collection centers.



Plastic packaging
Risk of suffocation

- Do not leave the packaging or any part of it unattended.
- Do not allow children to play with the plastic packaging bags.



Description/Assembly/Commands

Z
U

DESCRIPTION OF THE APPLIANCE (Fig. A)

- 1 Motor base
- 2 Coffee bean container (350 g)
- 3 Coffee bean container lid
- 4 Ground coffee container with lid
- 5 Container support plate
- 6 START/STOP button
- 7 Grinding functions selection knob
- 8 Grinding level adjustment lever
- 9 Grinder
- 10 Cleaning brush
- 11 Portafilter centering device

IDENTIFICATION PLATE

The identification plate states the technical data, serial number, and marking. The identification plate must never be removed.

BEFORE FIRST USE (Fig. A)

- Unpack the appliance carefully and remove all packaging materials and promotional labels.
- Wash all components, except for the motor base (1) and the grinder (9), with hot water and normal dish-washing liquid. Rinse all components thoroughly and dry them before using them.



The grinder must never be washed and must always be kept dry. Clean the grinder with the cleaning brush provided or with a hard-bristle brush.



Before use, check that all components are integral and have no cracks.

ASSEMBLY OF COMPONENTS (Fig. B-C-D)

- Position the container (2) on the motor base (1) making the two reference notches "∨" "∧" correspond, and then turn it clockwise until the two indications "∨" "▲" match.
- Position the lid (3) on the container (2) and press it down.
- Position the plate (5) on the motor base (1) in a way to secure it.
- Open the silicone cap of the ground coffee container (4) and position it on the plate (5).
- Make sure that the rubber dispenser cone is centered in the hole of the container lid (4) as shown in Fig. D.

DESCRIPTION OF CONTROLS (Fig. E-F)

Grinding adjustment lever (8)

The appliance has a lever (8), which allows to adjust the level of grinding appropriate to your use:

FINE	Fine grinding
MEDIUM	Medium grinding
COARSE	Coarse grinding

Move the lever to make the indicator (12) correspond with the desired grinding level.



Grinding quantity selection knob (7)

The appliance has 8 pre-set functions and a manual function, which can be selected using the knob (7).

Each function corresponds to a set amount of ground coffee.

Knob icon	Quantity
	1 Grinding for single espresso
	2 Grinding for double espresso
2	Grinding for 2 cups
4	Grinding for 4 cups
6	Grinding for 6 cups
8	Grinding for 8 cups
10	Grinding for 10 cups
12	Grinding for 12 cups
M	Manual function

In relation to the quantity selected, we recommend adjusting coffee grain by moving the indicator (12) as indicated in the following table.

Use	Level of Grinding indicator (12)	Functions knob (7)
Espresso coffee machine	FINE	1 - 2 
Moka		
Filter coffee machine	MEDIUM	2
		4
		6
French Press	COARSE	8
		10
		12

The Manual function (M) can be used at will with any level of grinding.



USE (Fig. A-E-F-H-H)



Make sure the upper grinder (9A) is inserted and secured in its seat.

- Insert the plug into the power outlet.
- Lift the lid (3) and introduce the coffee beans into the container (2).



A flashing LED on the knob means that the appliance is reporting an error: missing or incorrectly inserted bean container.

Grinding the coffee into the container (4)

- Position the powder container (4) on the plate (5), making sure the silicone cap is open.
- Select the desired level of grinding by positioning the indicator (12) on the gradation desired.
- Select the desired program by turning the knob (7) and making the red lock-nut indicator correspond with the desired program from "2" to "12".
- Press the START/STOP button (6) to start grinding. For all pre-set programs, grinding will end automatically (excluding the manual function (M)).
- When grinding has been completed, remove the container (4) from the appliance.
- To withdraw the ground coffee from the container (4), open it by turning the lid (13) counter-clockwise and remove it.



Grind an adequate amount of coffee, make sure that the coffee powder is less than the maximum level mark on the powder container.



During manual operation mode (M) stay near the coffee grinder: press START/STOP again to finish grinding. Stop grinding before the coffee powder passes the maximum level mark on the powder container.



Once ground, the coffee can quickly lose its aroma. For best results, use the coffee powder immediately after grinding. Store the powder container in a dark, cool and dry place. Make sure that the level of the coffee powder is lower than the maximum marking of the container and make sure that the lid of the container is tightly closed and screwed.

Grinding the coffee into the espresso coffee portafilter

- Use the relevant accessory (11) supplied and fix it as indicated in Figure 7 to facilitate centering of the portafilter. Position any portafilter under the dispensing cone.
- Select the FINE grinding level
- Select the "1" or "2" program according to the capacity of its portafilter.
- Press the START/STOP button (6) to start grinding. For all pre-set programs, the grinding will end automatically.
- When grinding has been completed, remove the portafilter.



Portafilter not supplied.



If the manual grinding operating time exceeds the safety time set (90 seconds), the motor stops automatically.



During the grinding phase, do not rotate the knob (7) from one program to another and do not move the grain selection lever (8).



If a finer level of grinding than that currently used is to be set, it is highly recommended to remove the grinder and clean it, removing any residual beans, before proceeding with a new grinding operation. See the **CLEANING AND MAINTENANCE** section to remove the grinder.



A bean blocking system allows the container (2) to be lifted from the motor base (1) in a safe manner, preventing the beans from escaping.



The coffee grinder has an auto-switch-off button (stand-by) if it is not used after 90 seconds. Press the **START/STOP** button to re-activate the product.

GRINDING TIMES (Fig. E-F)

The functions envision pre-set supply settings of ground coffee. However, depending on personal taste, the pre-set amount of ground coffee can be increased or decreased, thus customizing the different functions.

Customize the amount of grinding for espresso coffee.

- Make sure that the grinding indicator (12) is positioned at an adequate grinding level for espresso coffee (FINE).
- Turn the knob (7) to "1 .
- Press the **START/STOP** button (6) to start grinding and hold it down for the desired time; the lock nut (14) flashes during the programming phase.
- On releasing the button, grinding stops, the lock-nut stops flashing and the new setting is memorized.



By modifying the amount of single espresso coffee ground, the amount of double espresso coffee is also modified automatically.

Customizing the amount of ground coffee for American/French press coffee.

- Make sure that the grinding indicator (12) is positioned at an adequate grinding level for Americano/French Press coffee (MEDIUM/COARSE).
- Turn the knob (7) to "2".
- Press the **START/STOP** button (6) to start grinding and hold it down for the desired time; the lock nut (14) flashes during the programming phase.
- On releasing the button, grinding stops, the lock-nut stops flashing and the new setting is saved.



Cleaning and maintenance



By modifying the amount of American/French press coffee ground, for the 2-cup selection, the amount of espresso coffee for the other pre-set functions present on the knob is modified automatically (from 2 to 12).

Resetting factory values

To reset the factory values:

- Turn the knob (7) onto program "12".
- Press the START/STOP button (6) and hold it down for 5 seconds. The lock-nut (14) flashes 5 times indicating that all factory-set values have been reset (for Espresso functions and Filter Coffee/French Press functions).

CLEANING AND MAINTENANCE (Fig. A-H-I-L)

Z
U

- Make sure the coffee bean container (2) is empty and then run in manual mode (M) to remove any coffee residue from the grinder.



Before carrying out any cleaning operation, ALWAYS disconnect the plug from the power outlet. Never immerse the motor base (1) in water or other liquids.

- Remove the container (2) by turning it counter-clockwise.
- Remove any coffee beans present in the machine using the cleaning brush (10) supplied.
- Lift the handle (15) and turn the upper grinder (9a) counter-clockwise to release it and then remove it.
- Clean the upper grinder (9a) and the lower grinder (9b) and the coffee outlet cavity using a hard bristle brush or the supplied cleaning brush (10).
- Re-mount the upper grinder (9a) making the two notches "∨" "∧" correspond and rotating clockwise to fix it "∨" "▲".
- The ground coffee bean container (2,4), the lid (3), and the plate (5) can be washed using warm water and neutral detergent.
- The motor base (1) can be cleaned using a damp cloth, avoiding the use of detergents or abrasive materials.

Cleaning and maintenance



What To Do If.....

Problem	Possible causes	Solution
The appliance does not work	Plug not connected	Connect the plug
	The coffee bean container is not inserted correctly	Check that the coffee bean container is inserted in the relative plate (5).
The LED on the knob flashes	The motor thermal protection is activated automatically after 90 seconds of continuous operation.	Wait (approx. 15 minutes) for the thermal protection to reset.
	The coffee bean container is not inserted correctly	Check that the coffee bean container is inserted on the motor base. See the section "Assembly of Components" for directions on how to mount the bean container.
The appliance stops during operation	The motor thermal protection is activated automatically after 90 seconds of continuous operation	Wait (approx. 15 minutes) for the thermal protection to reset.
The appliance works but ground coffee does not escape.	No coffee beans in the relative container.	Load the coffee beans.
	Grinder blocked.	Remove the grinder and check there are no objects blocking rotation.
It is difficult to set the grinding level of the coffee or there is a low amount of coffee.	The upper part of the grinder (9a) is missing	Insert and secure the upper grinder (9a) in its seat
	Grinders worn.	Replace the grinders by taking the appliance to an authorized after-sales center.



Contact local technical support if the problem is not solved or in case of other types of faults.