

ASSEMBLY INSTRUCTIONS
COASTER FINE FURNITURE



Fine Furniture for every stage of life

305878KE (B1&B2)
Eastern King Bed

ITEM: 305878KE (B1&B2)



ASSEMBLY INSTRUCTIONS

ASSEMBLY TIPS:

1. Remove hardware from box and sort by size.
2. Please check to see that all hardware and parts are present prior to start of assembly.
3. Please follow attached instructions in the same sequence as numbered to assure fast & easy assembly.



WARNING!

1. Don't attempt to repair or modify parts that are broken or defective. Please contact the store immediately.
2. This product is for home use only and not intended for commercial establishments.













ASSEMBLY TIME

30 MINUTES



PARTS IDENTIFICATION

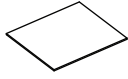

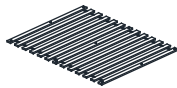

B1 (BOX 1)

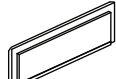
A	HAEDBOARD PANEL		1PC
B	LEFT HEADBOARD LEG (WITH "L" LABEL)		1PC
C	RIGHT HEADBOARD LEG (WITH "R" LABEL)		1PC
D	BED RAIL DRAWER BACK PANEL (WITH "D" LABEL)		2PCS
E	DRAWER LEFT SIDE PANEL (WITH "E" LABEL)		4PCS
F	DRAWER RIGHT SIDE PANEL (WITH "F" LABEL)		4PCS
G	BED RAIL DRAWER BOTTOM PANEL		2PCS

H	BED RAIL DRAWER SUPPORT		4PCS
I	FOOTBOARD DRAWER BACK PANEL (WITH "I" LABEL)		2PCS
J	FOOTBOARD DRAWER BOTTOM PANEL		2PCS
K	FOOTBOARD DRAWER SUPPORT		4PCS
L	CASTER WITH SCREW		16SETS
M	ROLL SLAT (13pcs)		1SET

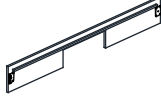
B2 (BOX 2)

N	BED RAIL DRAWER FRONT PANEL		2PCS
O	FOOTBOARD DRAWER FRONT PANEL		2PCS
P	FOOTBOARD FRAME		1PC
Q	FOOTBOARD LEG		2PCS

R	BED RAIL		2PCS
S	BED RAIL SUPPORT LEG		4PCS
T	CENTER RAIL		1PC
U	CENTER RAIL SUPPORT WITH LEVELER		3PCS

NOTE:

Phillips head screw driver is required in the assembly process; however, manufacturer does not provided this item.

ITEM: 305878KE (B1&B2)



ASSEMBLY INSTRUCTIONS

ASSEMBLY TIPS:

1. Remove hardware from box and sort by size.
2. Please check to see that all hardware and parts are present prior to start of assembly.
3. Please follow attached instructions in the same sequence as numbered to assure fast & easy assembly.







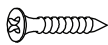

WARNING!

1. Don't attempt to repair or modify parts that are broken or defective. Please contact the store immediately.
2. This product is for home use only and not intended for commercial establishments.

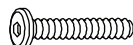
HARDWARE IDENTIFICATION

Z-B2 (BOX 2) - HARDWARE PACK IS LOCATED IN 305878KE (B2)

1	SHORT BOLT (M8 x 20MM - RBW)		8PCS	6	FLAT HEAD SCREW (M4 x 32MM - RBW)		38PCS
2	MEDIUM BOLT (M6 x 35MM - RBW)		16PCS	7	WOOD DOWEL (M8 x 30MM)		64PCS
3	LONG BOLT (M6 x 50MM - RBW)		11PCS	8	SMALL ALLEN WRENCH (M4 x 65MM - BLK)		1PC
4	LOCK WASHER (15/64" X 13 Ø - RBW)		14PCS	9	BIG ALLEN WRENCH (M5 x 65MM - BLK)		1PC
5	FLAT WASHER (15/64" X 19 Ø - RBW)		14PCS				

NOTE:

Phillips head screw driver is required in the assembly process; however, manufacturer does not provided this item.

ITEM: **305878KE (B1&B2)**

ASSEMBLY INSTRUCTIONS

STEP 1

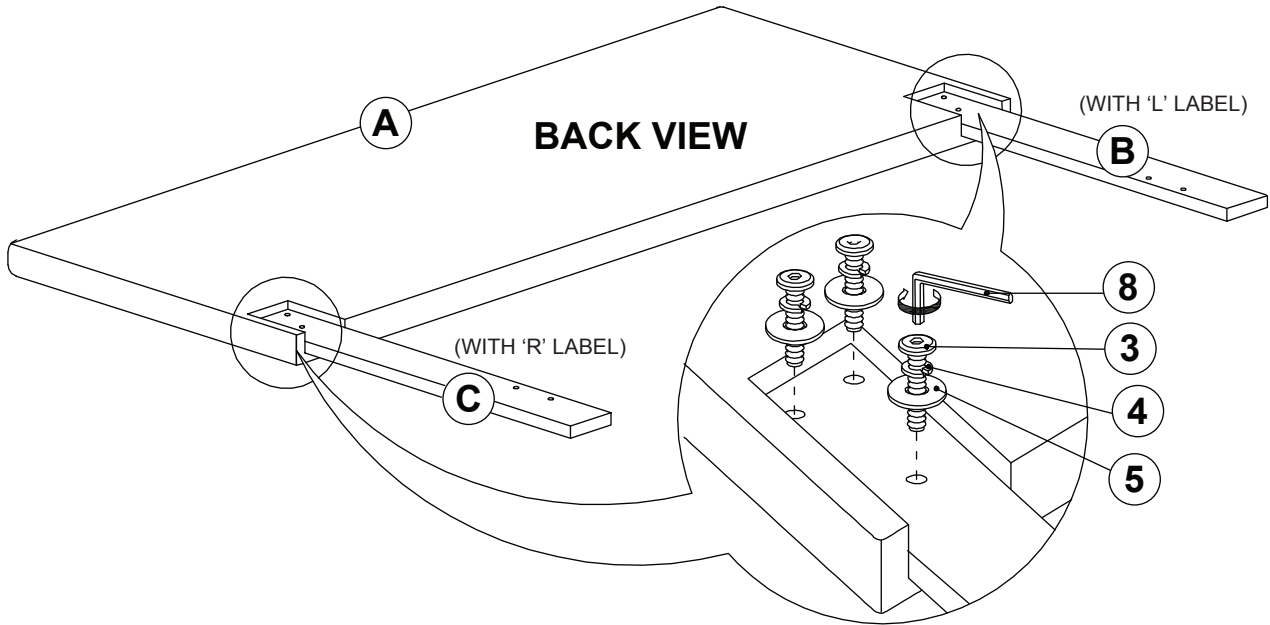

STEP 2

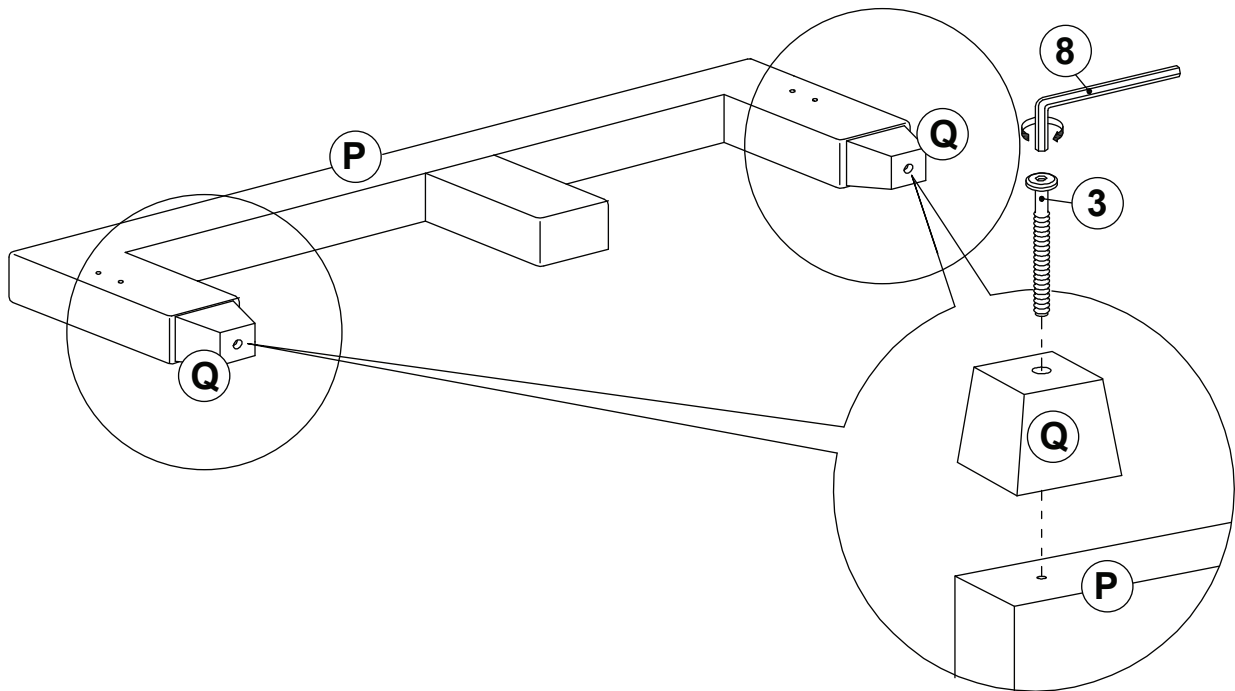

ITEM: **305878KE (B1&B2)**

ASSEMBLY INSTRUCTIONS

STEP 3

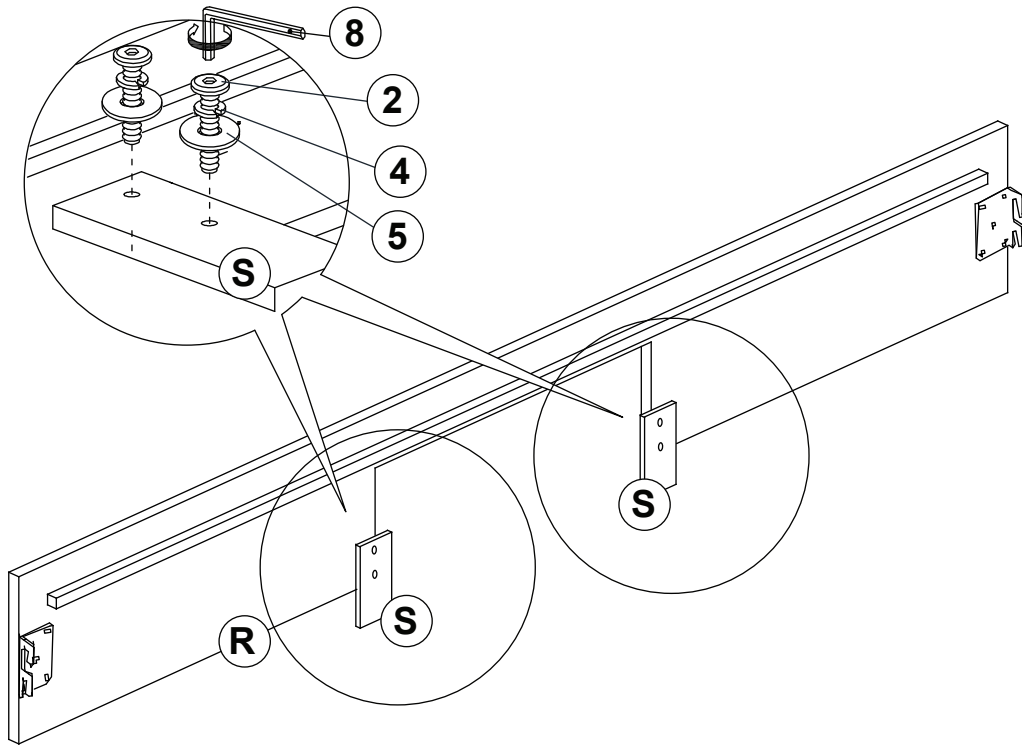

STEP 4

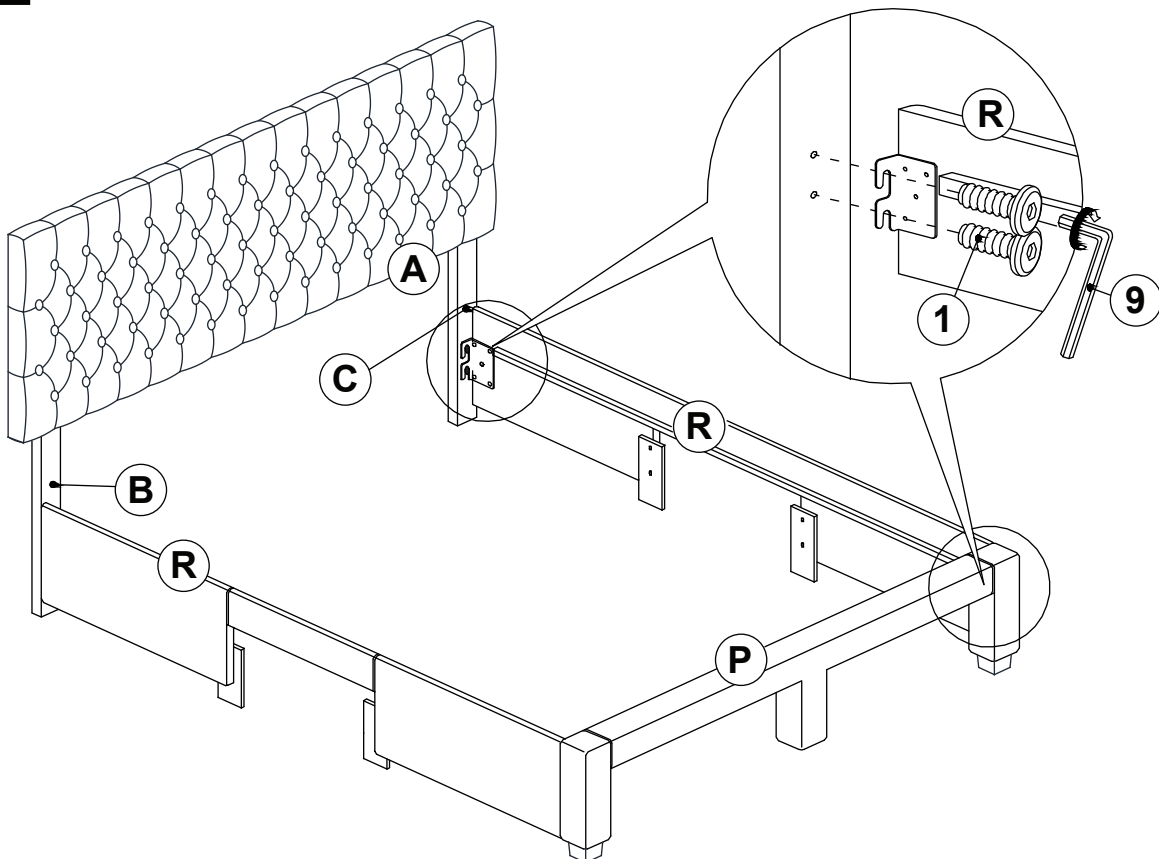

ITEM: **305878KE (B1&B2)**



ASSEMBLY INSTRUCTIONS

STEP 5

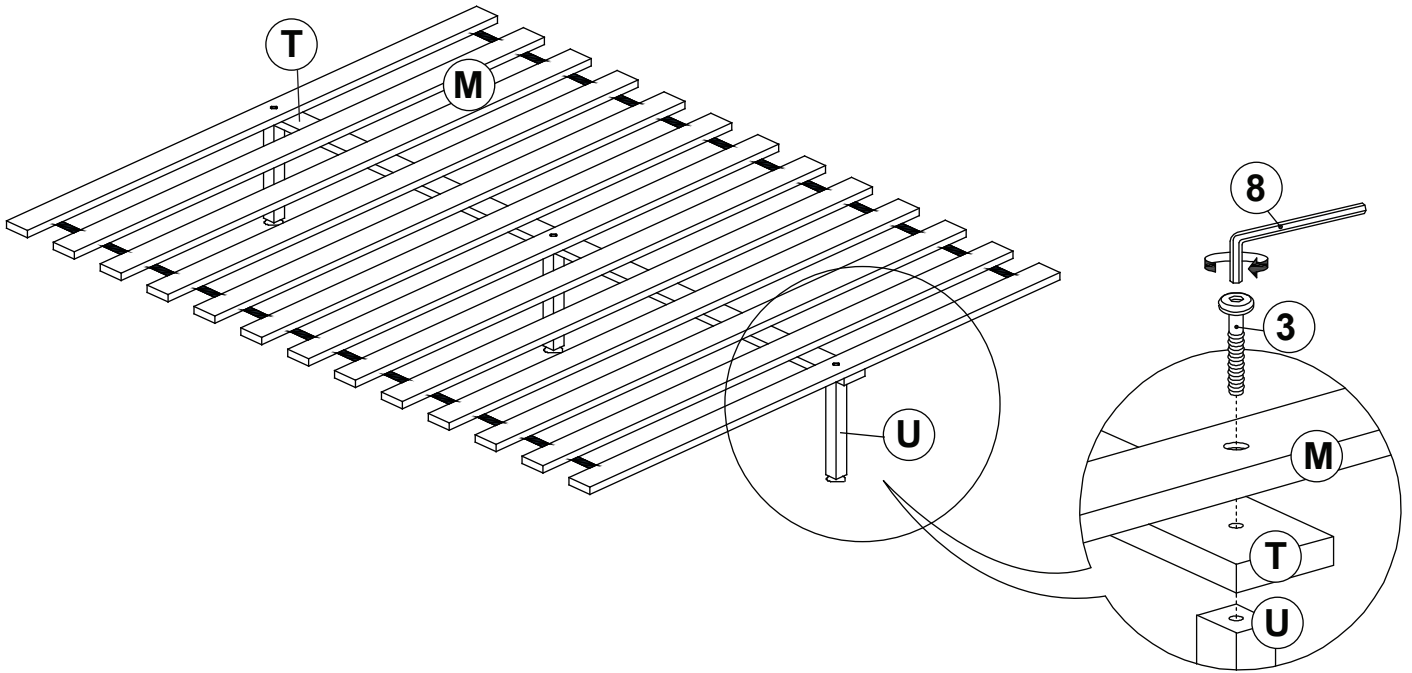

STEP 6

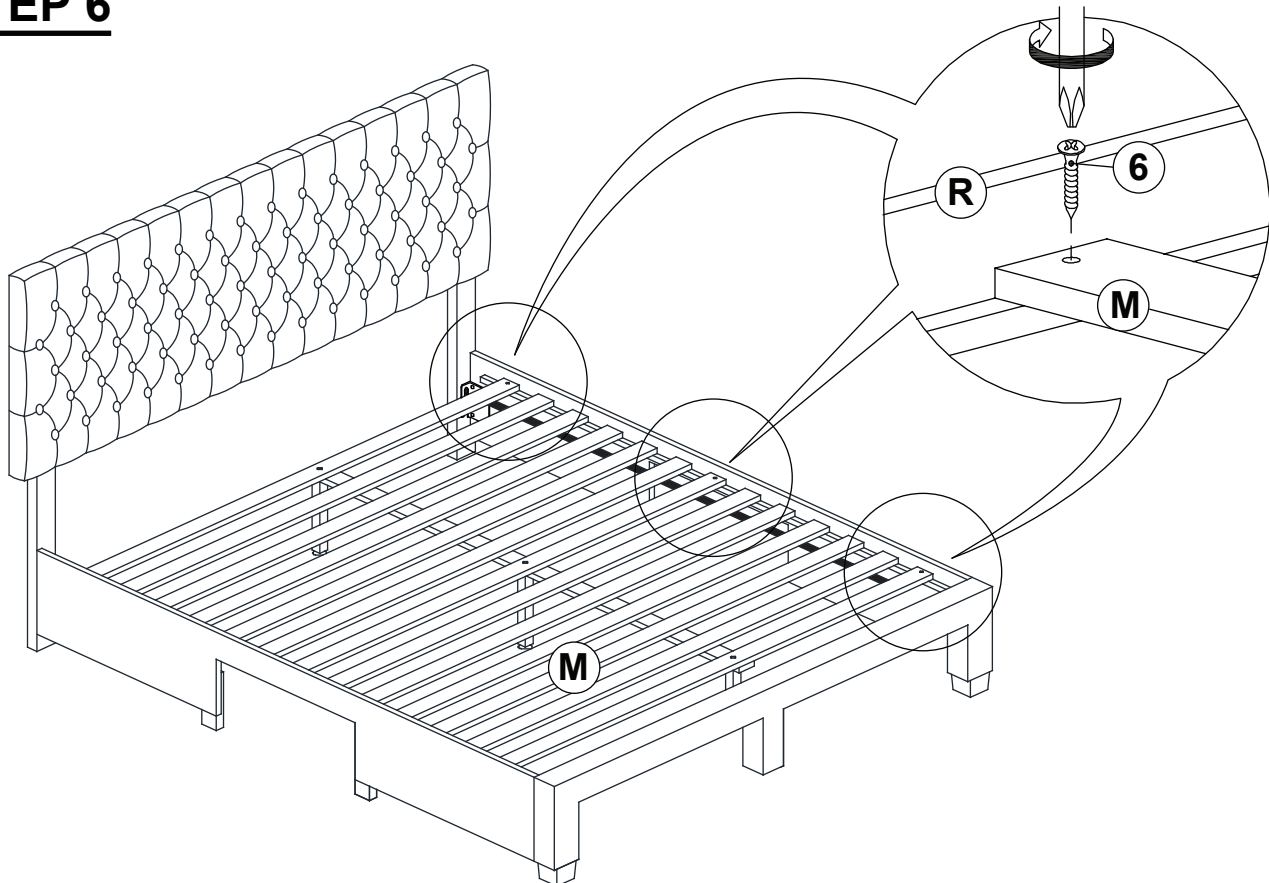

ITEM: **305878KE (B1&B2)**

ASSEMBLY INSTRUCTIONS

STEP 7

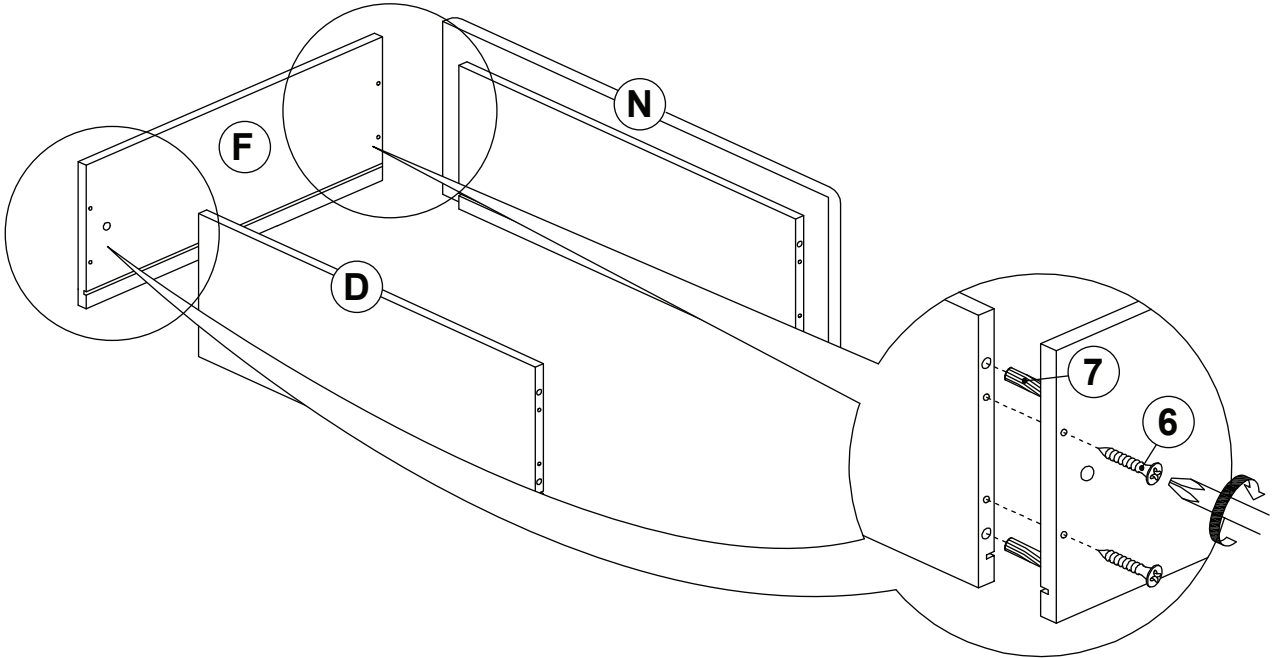

STEP 8

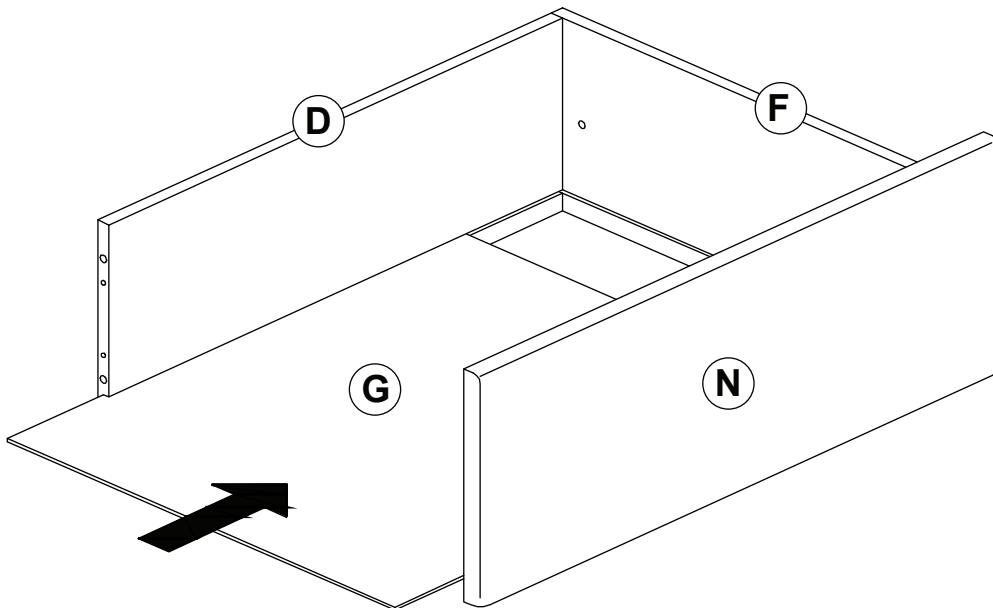

ITEM: **305878KE (B1&B2)**

ASSEMBLY INSTRUCTIONS

STEP 9

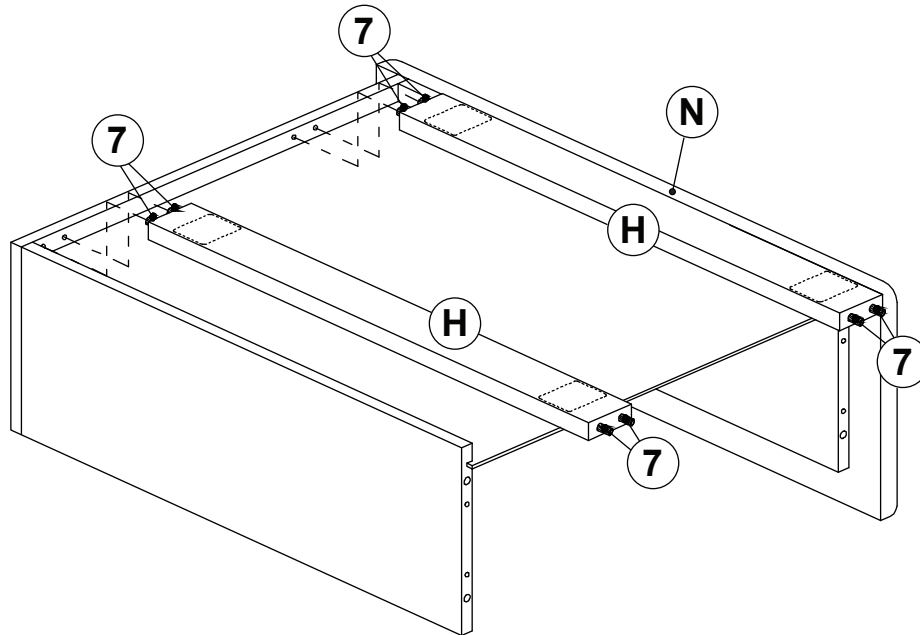

STEP 10

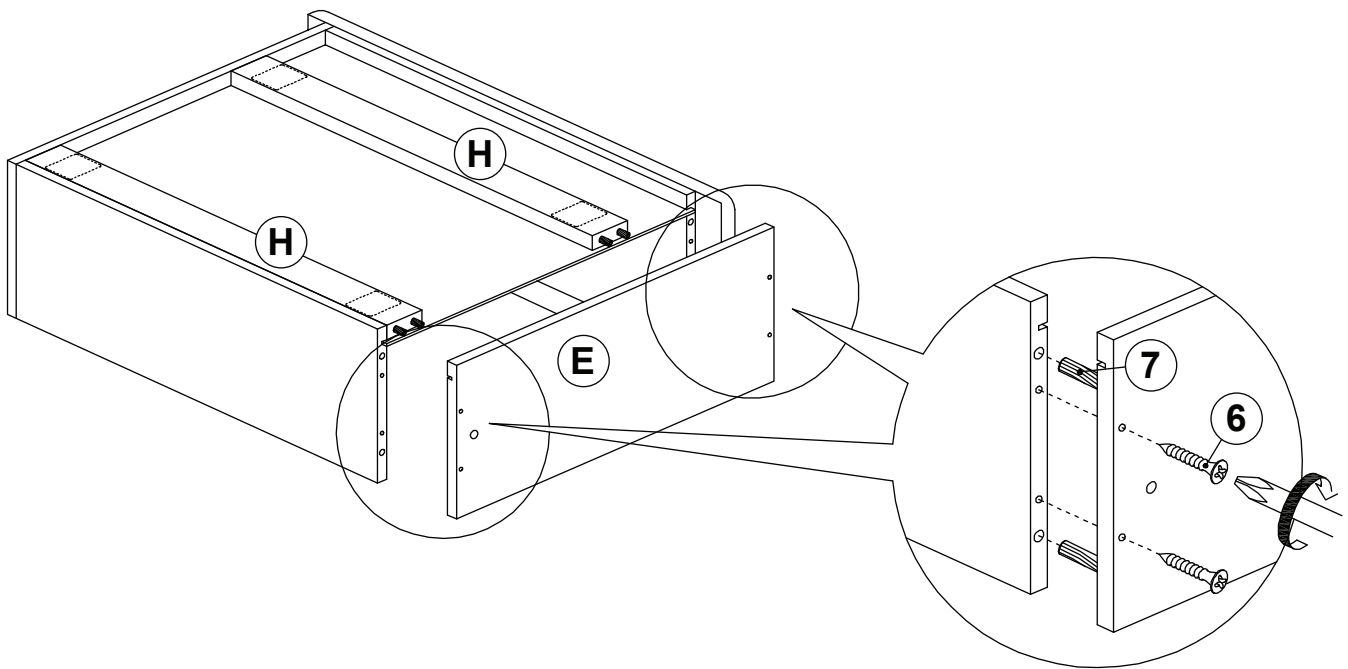

ITEM: **305878KE (B1&B2)**

ASSEMBLY INSTRUCTIONS

STEP 11

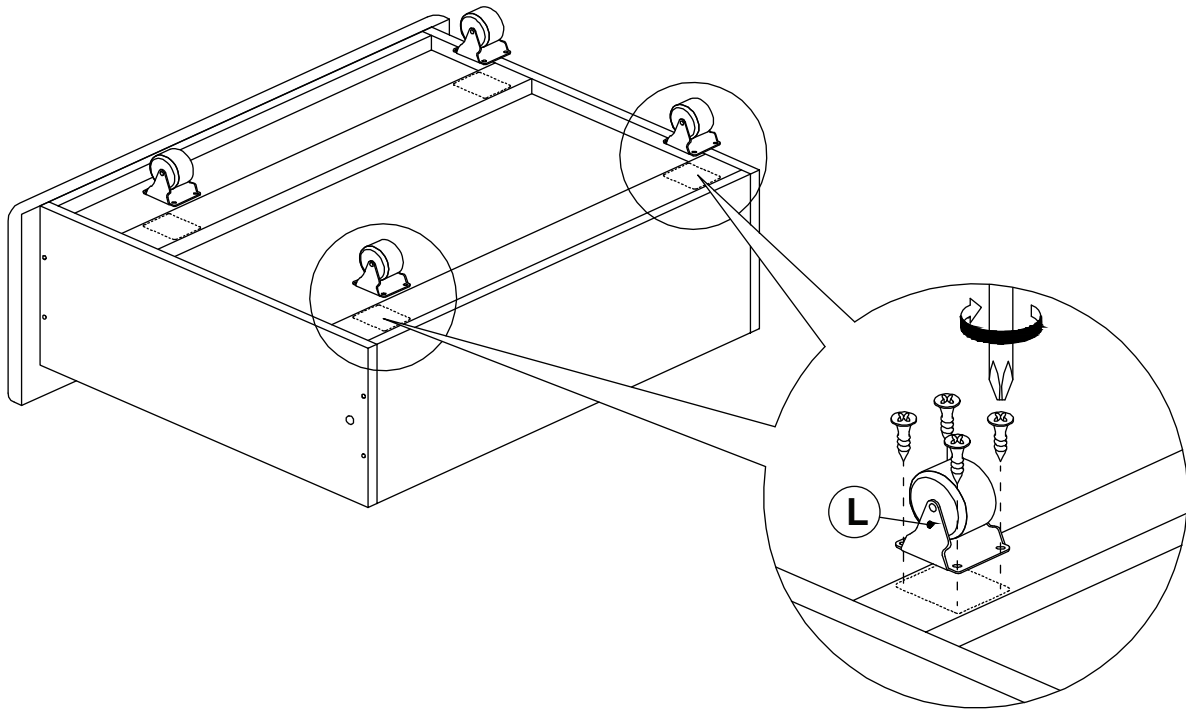

STEP 12

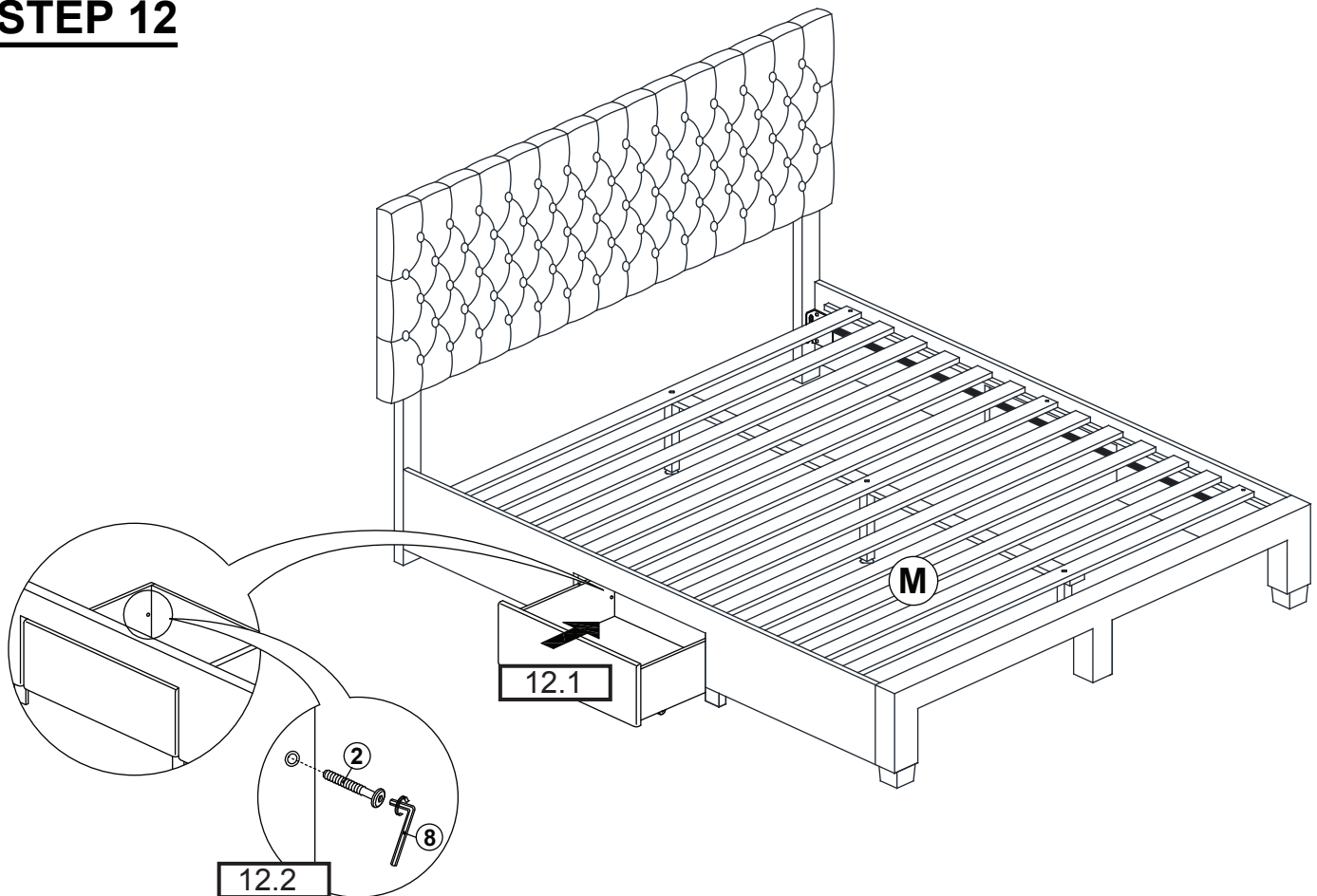

ITEM: **305878KE (B1&B2)**

ASSEMBLY INSTRUCTIONS

STEP 13

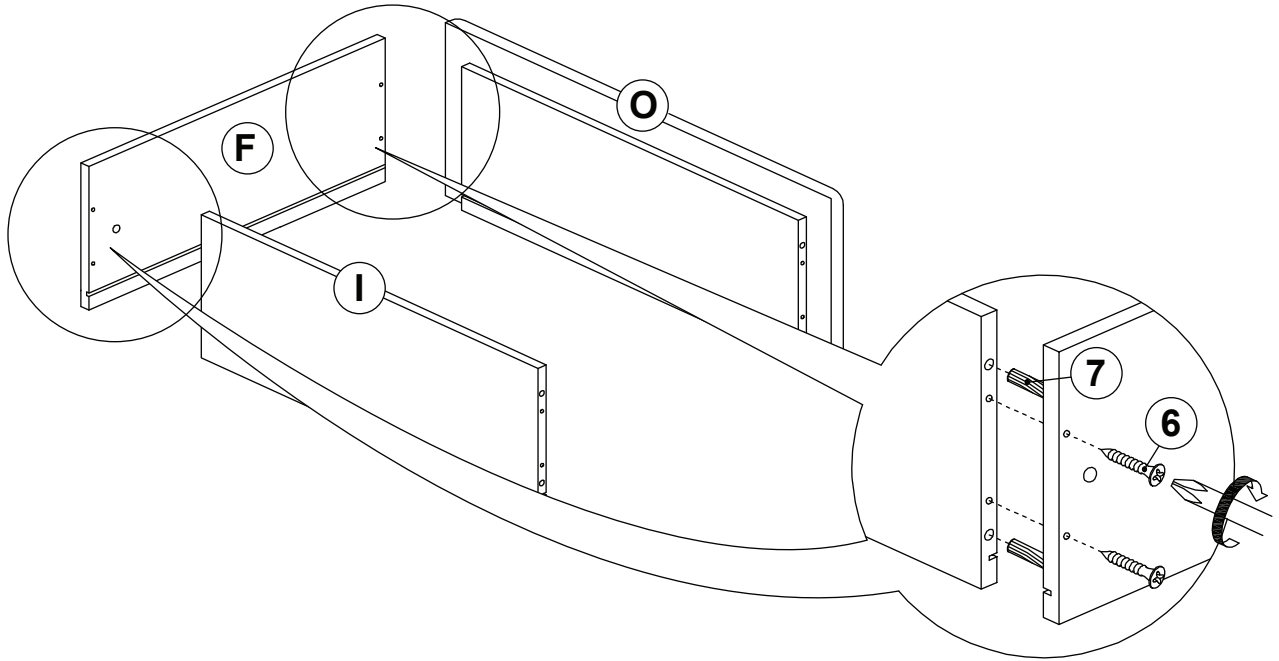

STEP 14

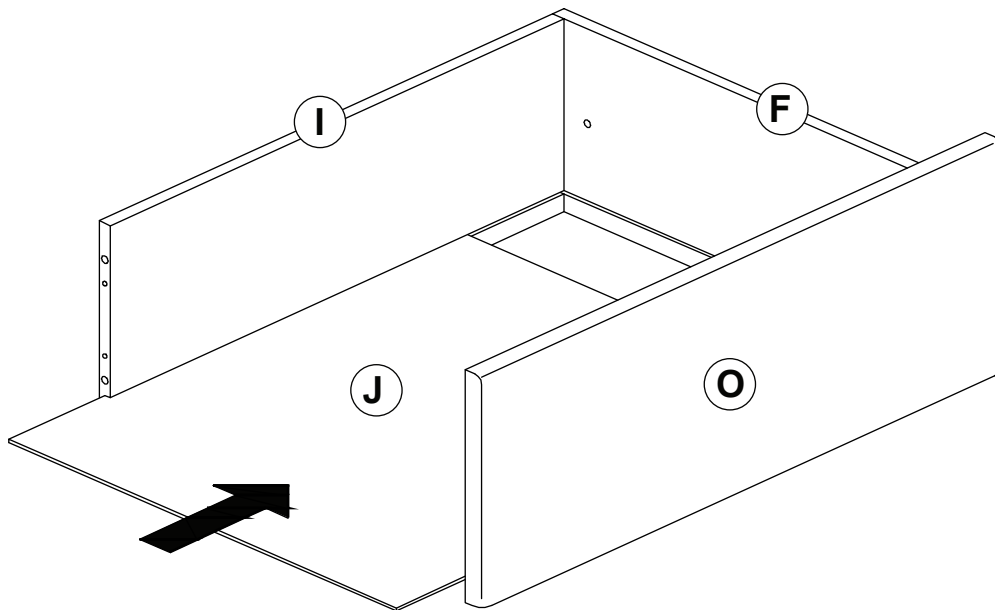

ITEM: **305878KE (B1&B2)**

ASSEMBLY INSTRUCTIONS

STEP 15

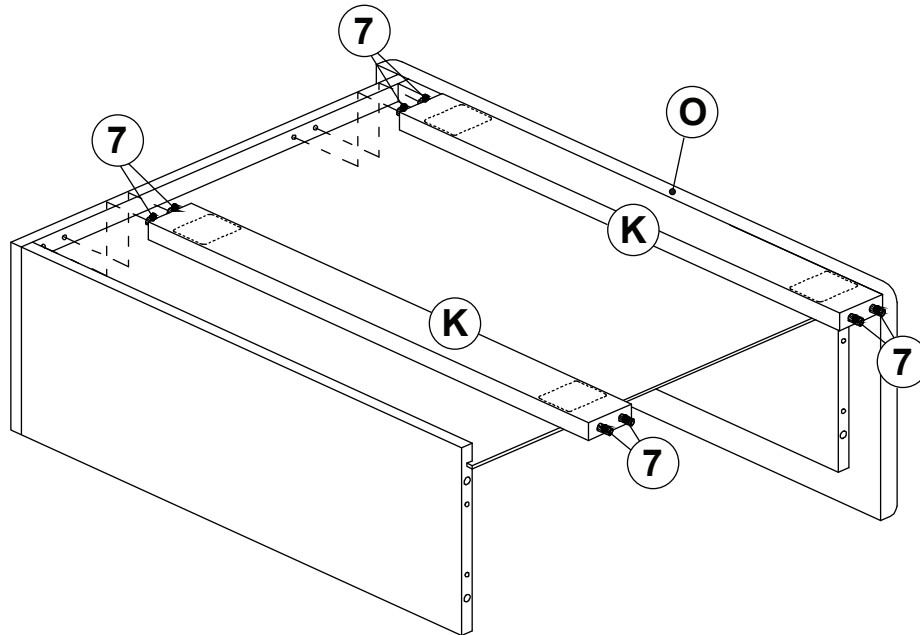

STEP 16

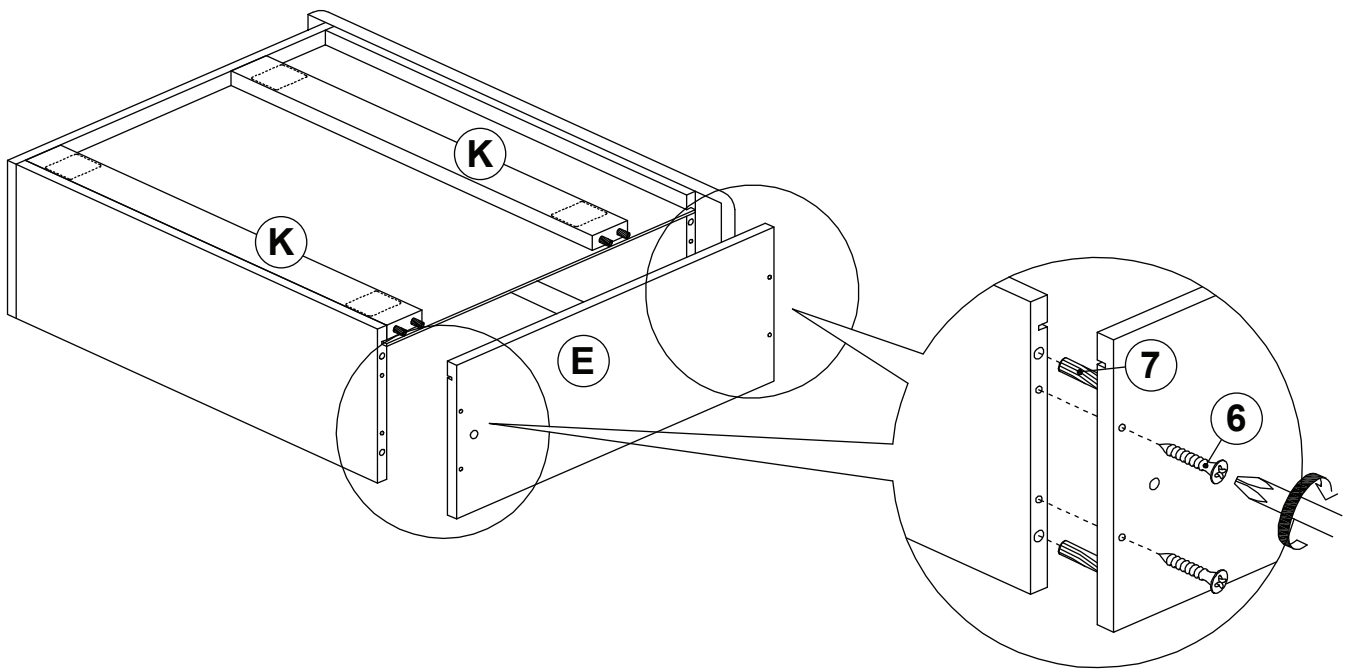

ITEM: **305878KE (B1&B2)**

ASSEMBLY INSTRUCTIONS

STEP 17

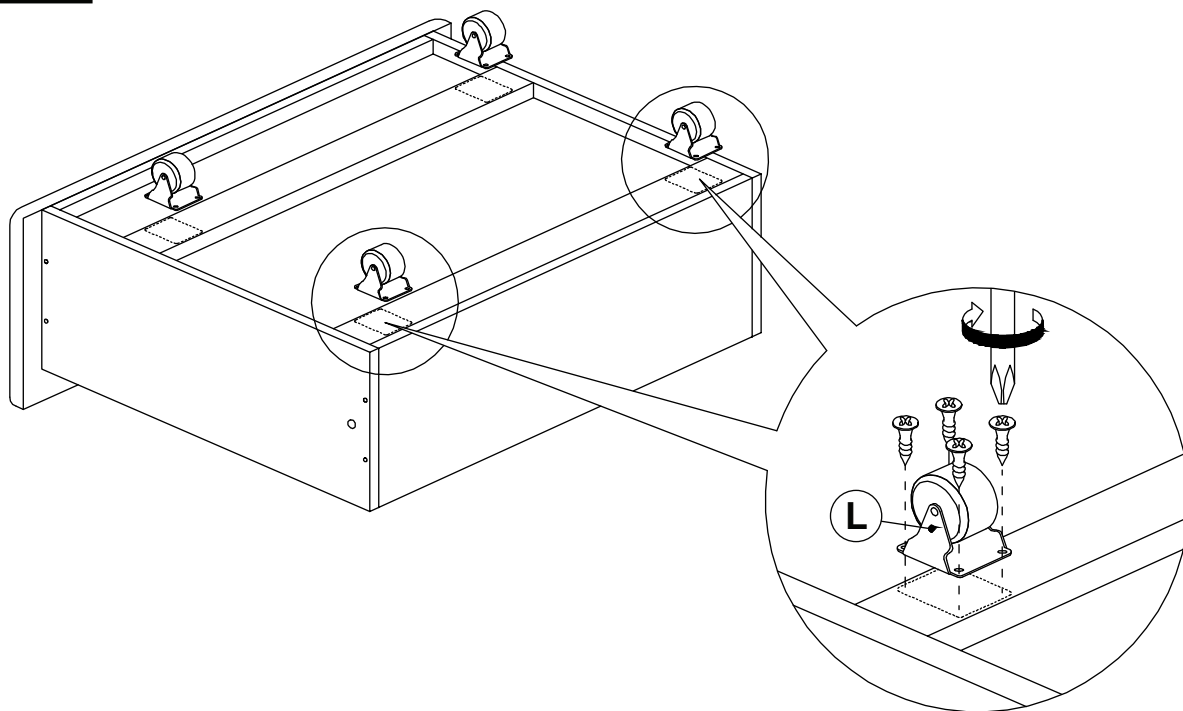

STEP 18

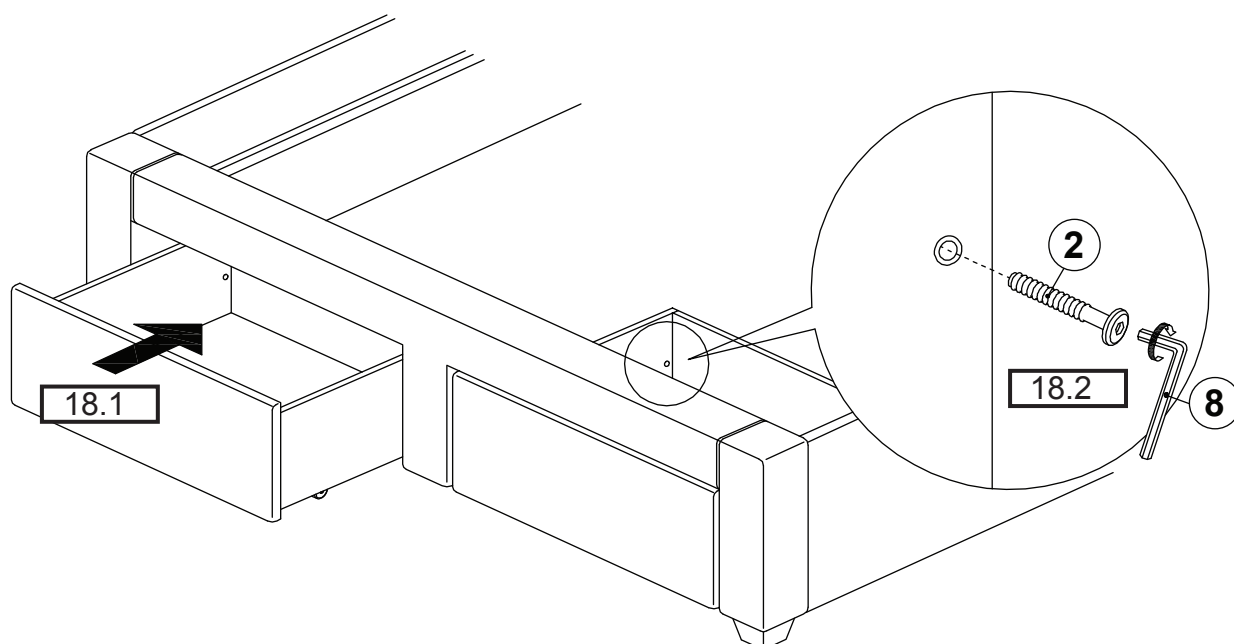

ITEM: **305878KE (B1&B2)**



ASSEMBLY INSTRUCTIONS

STEP 19

COMPLETE

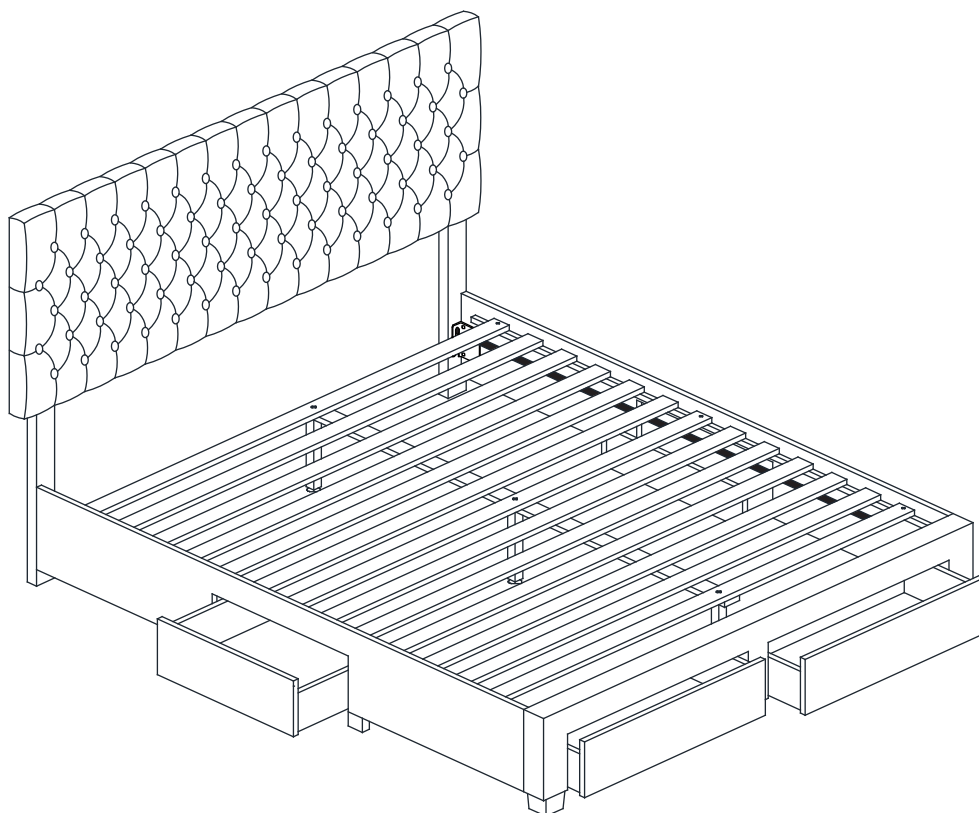

ITEM: 305878KE (B1&B2)

INNER SIZE : 76.57" x 81.1"

INNER SIZE OF DRAWER BOX (FRONT) : 30.63" x 17.72" x 5.91"

INNER SIZE OF DRAWER BOX (SIDE) : 22.76" x 17.72" x 5.91"

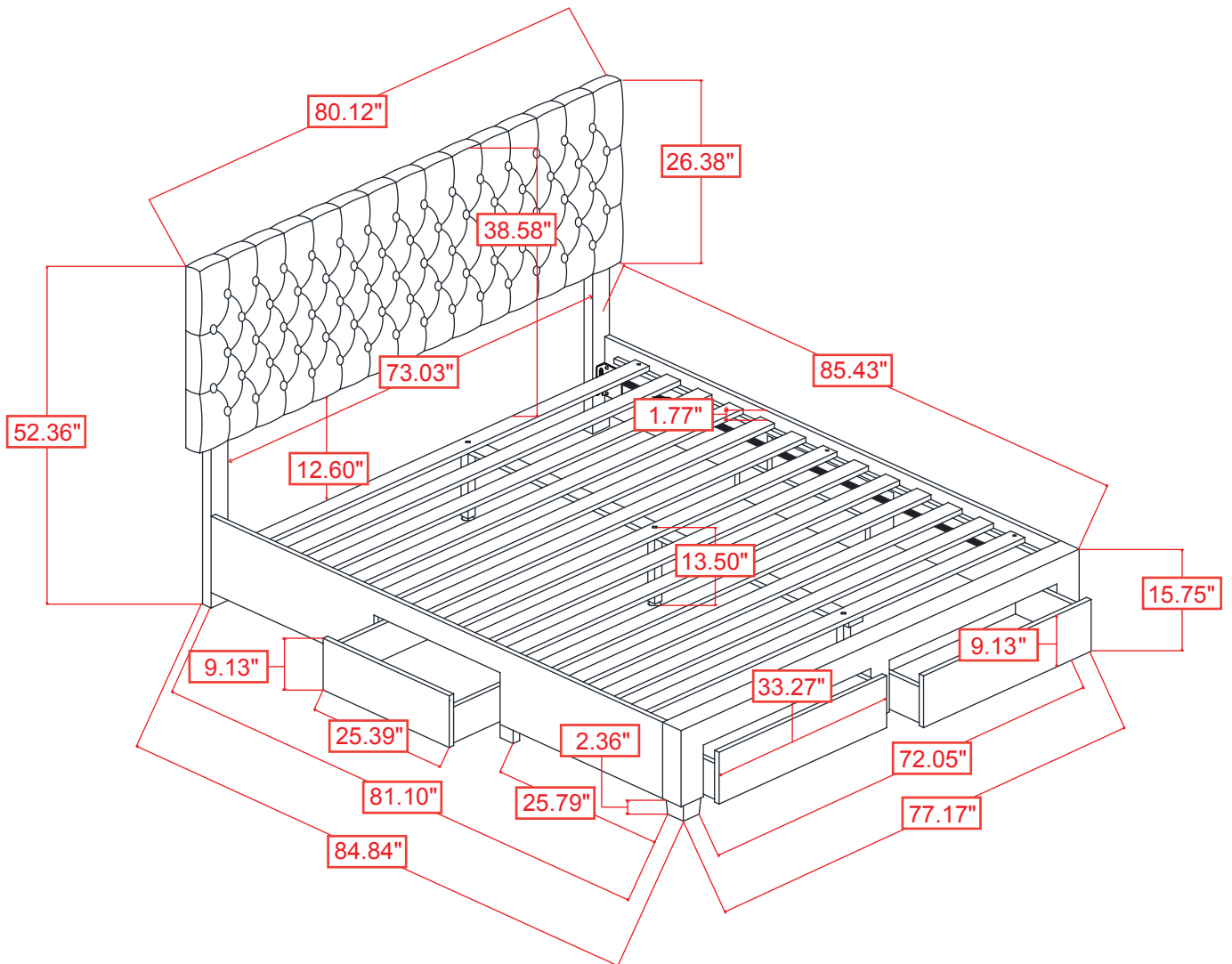

Note : Dimension tolerance $\pm 5\%$