

**29R • 21" ADA Solid Door Refrigerator • ADA Series**

**FEATURES & BENEFITS**



BLACK SOLID



BLACK SOLID (LOCK)



WHITE SOLID



WHITE SOLID (LOCK)

<b>PERFORMANCE</b>	<ul style="list-style-type: none"> <li>• Volume of 3.3 cu ft holds up to 35 bottles (12 oz) or 48 cans (12 oz)</li> <li>• Mechanical Dial Control is conveniently located on the grille</li> <li>• Temperature range: 34°F - 45°F</li> <li>• Mechanical passive cooling system</li> </ul>
<b>INTERIOR/EXTERIOR</b>	<ul style="list-style-type: none"> <li>• Three removable tempered glass shelves</li> <li>• Three fixed shelves in door</li> <li>• Door swing is field reversible for non-lock models</li> <li>• Door lock models are available, and must be ordered hinge specific</li> </ul>
<b>INTEGRATION</b>	<ul style="list-style-type: none"> <li>• Unit is designed to be built-in or can be freestanding</li> <li>• Accepts a 1/4" custom insert panel</li> <li>• Available in the following finishes: Black or White</li> </ul>

**MODEL DETAILS**

Model	Voltage/Hz	Door Swing	Finish	Shipping Weight
U-29RB-00A	115 / 60	Field Reversible	Black Solid	89 lbs
U-29RB-13A	115 / 60	Right-Hand Hinge	Black Solid (Lock)	89 lbs
U-29RB-15A	115 / 60	Left-Hand Hinge	Black Solid (Lock)	89 lbs
U-29RW-00A	115 / 60	Field Reversible	White Solid	89 lbs
U-29RW-13A	115 / 60	Right-Hand Hinge	White Solid (Lock)	89 lbs
U-29RW-15A	115 / 60	Left-Hand Hinge	White Solid (Lock)	89 lbs

ADA Series • 21" ADA Solid Door Refrigerator • 29R

**DIMENSIONS**

Dimensions shown apply to all finishes, including Integrated (INT) models with 3/4" integrated panel/frame installed.

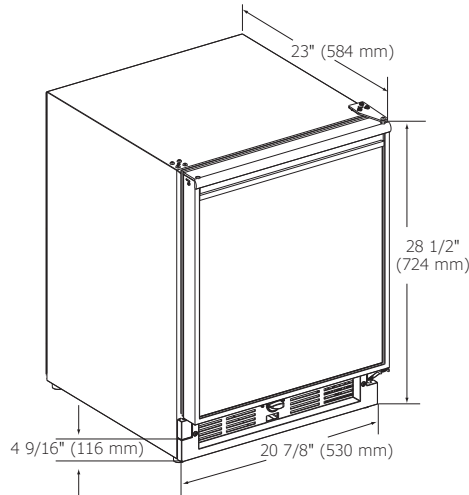

**CABINET CUT-OUT**

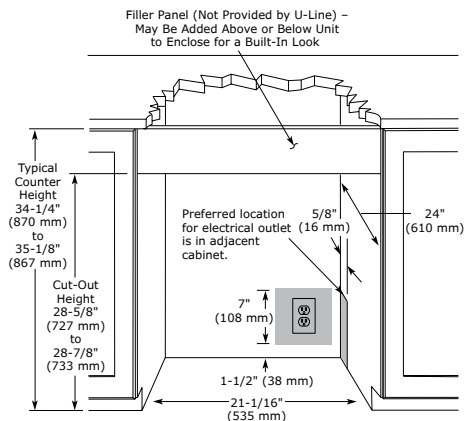

**SPECIFICATIONS**

Model	29R
Amps: Running	1.2
Capacity: Bottle (12 oz)	35
Capacity: Can (12 oz)	48
Capacity: Volume (cu ft)	3.3
Control Type	Mechanical Dial
Dimensions: Product Depth	23" / 584 mm
Dimensions: Product Height	28 1/2" / 724 mm
Dimensions: Product Width	20 7/8" / 530 mm
Energy Consumption: Avg. Per Year	230 kWh
ENERGY STAR / CEE RATING	ENERGY STAR / Tier 1
Product Weight: Max	80 lbs
Refrigerant Type	R600a
Sabbath (Star K Certified)	No
Temperature Range	34°F - 45°F

**INSTALLATION NOTES**

- Cutout includes the additional 1/4" width overall to ensure proper installation.
- No additional clearance around sides, top or rear of unit is needed for ventilation.
- Do not obstruct front grille air flow.

**COOLING SYSTEM**



**ELECTRICAL REQUIREMENTS**

This unit requires a grounded a polarized 115 VAC, 60 Hz, 15 A power supply (normal household current).

Please visit [u-line.com](http://u-line.com) to view this model's User Guide. All specifications are subject to change without notice.



Residential & Commercial