

*ASSEMBLY INSTRUCTIONS
COASTER FINE FURNITURE*



Fine Furniture for every stage of life

182303
CORNER BAR CABINET

ITEM: 182303



ASSEMBLY INSTRUCTIONS

ASSEMBLY TIPS:

1. Remove hardware from box and sort by size.
2. Please check to see that all hardware and parts are present prior to start of assembly.
3. Please follow attached instructions in the same sequence as numbered to assure fast & easy assembly.



WARNING!

1. Don't attempt to repair or modify parts that are broken or defective. Please contact the store immediately.
2. This product is for home use only and not intended for commercial establishments.

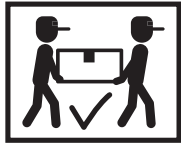

ASSEMBLY TIME

90 MINUTES

PARTS IDENTIFICATION

AN	UPPER LEFT SIDE PANEL		1 PC	HN	UPPER CROSS PANEL		2 PCS
BN	UPPER RIGHT SIDE PANEL		1 PC	IN	BOTTOM PANEL		1 PC
CN	LOWER LEFT SIDE PANEL		1 PC	JN	LOWER SHELF PANEL		1 PC
DN	LOWER RIGHT SIDE PANEL		1 PC	KN	MIDDLE SHELF PANEL		1 PC
EN	SMALL LEFT DIVIDER PANEL		1 PC	LN	UPPER SHELF PANEL		1 PC
FN	SMALL RIGHT DIVIDER PANEL		1 PC	MN	TOP PANEL		1 PC
GN	DIVIDER PANEL		2 PCS	NN	LEFT LOWER BACK PANEL		1 PC

NOTE:

Phillips head screw driver is required in the assembly process; however, manufacturer does not provide this item.

ITEM: 182303

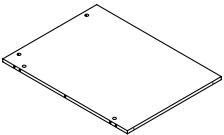
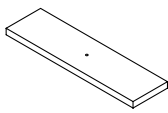
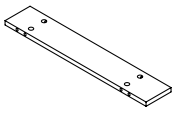
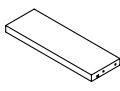
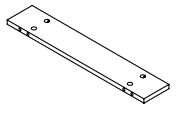
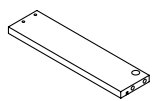
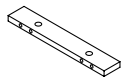
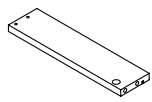
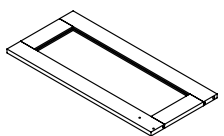
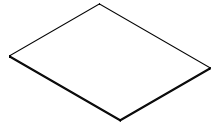
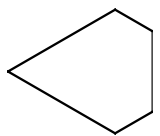
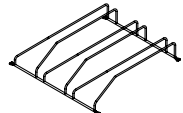









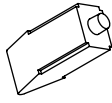

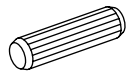

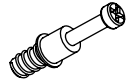

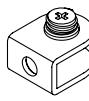
ON	RIGHT LOWER BACK PANEL		1 PC	UN	DRAWER FRONT PANEL		1 PC
PN	LEFT UPPER BACK PANEL		1 PC	VN	DRAWER BACK PANEL		1 PC
QN	RIGHT UPPER BACK PANEL		1 PC	A1N	DRAWER LEFT SIDE PANEL		1 PC
RN	LOWER CROSS PANEL		1 PC	B1N	DRAWER RIGHT SIDE PANEL		1 PC
SN	GLASS DOOR		1 PC	C1N	DRAWER BOTTOM PANEL		1 PC
TN	GLASS		1 PC	D1N	GLASS HOLDER		1 PC

NOTE:

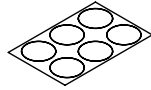
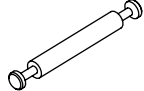
Phillips head screw driver is required in the assembly process; however, manufacturer does not provide this item.

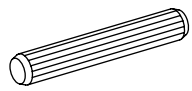
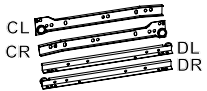
HARDWARE IDENTIFICATION

ZN

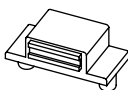
NO	DESCRIPTION	FIGURE	Q'TY	NO	DESCRIPTION	FIGURE	Q'TY
1	GLUE 40g		2 PCS	12	SCREW FOR DOOR Ø6.5x10mm RBW		1 PC
2	WOODEN DOWEL Ø8x30mm		70 PCS	13	FIXED DOOR DAMPER		1 PC
3	CAM BOLT Ø7x35.5mm SR		40 PCS	14	FLEXIBLE DOOR DAMPER		1 PC
4	CAM LOCK Ø15x12mm SR		48 PCS	15	GLASS CLAMP SR		3 PCS
5	SCREW Ø4.5x42mm SR		14 PCS	16	SCREW Ø4x15mm SR FOR GLASS CLAMP		3 PCS
6	PLASTIC FEET Ø15mm		8 PCS	17	STICKER Ø 20mm		10 PCS
7	CAM BOLT Ø7x63mm SR		4 PCS	18	SCREW Ø4x17mm SR		4 PCS
8	WOODEN DOWEL Ø8x50mm		4 PCS	19	GLIDES L = 300mm BLK		1 SET
9	HANDLE		2 PCS	20	GLIDES SCREW Ø3x12mm BLK		12 PCS
10	HANDLE BOLT Ø4x25mm BLK		2 PCS	21	SCREW Ø4.3x35mm SR		4 PCS
11	MAGNETIC CATCH		1 PC				

ZN19 not included in blister packaging.

NOTE:

Phillips head screw driver is required in the assembly process; however, manufacturer does not provide this item.

ITEM: 182303

STEP 1

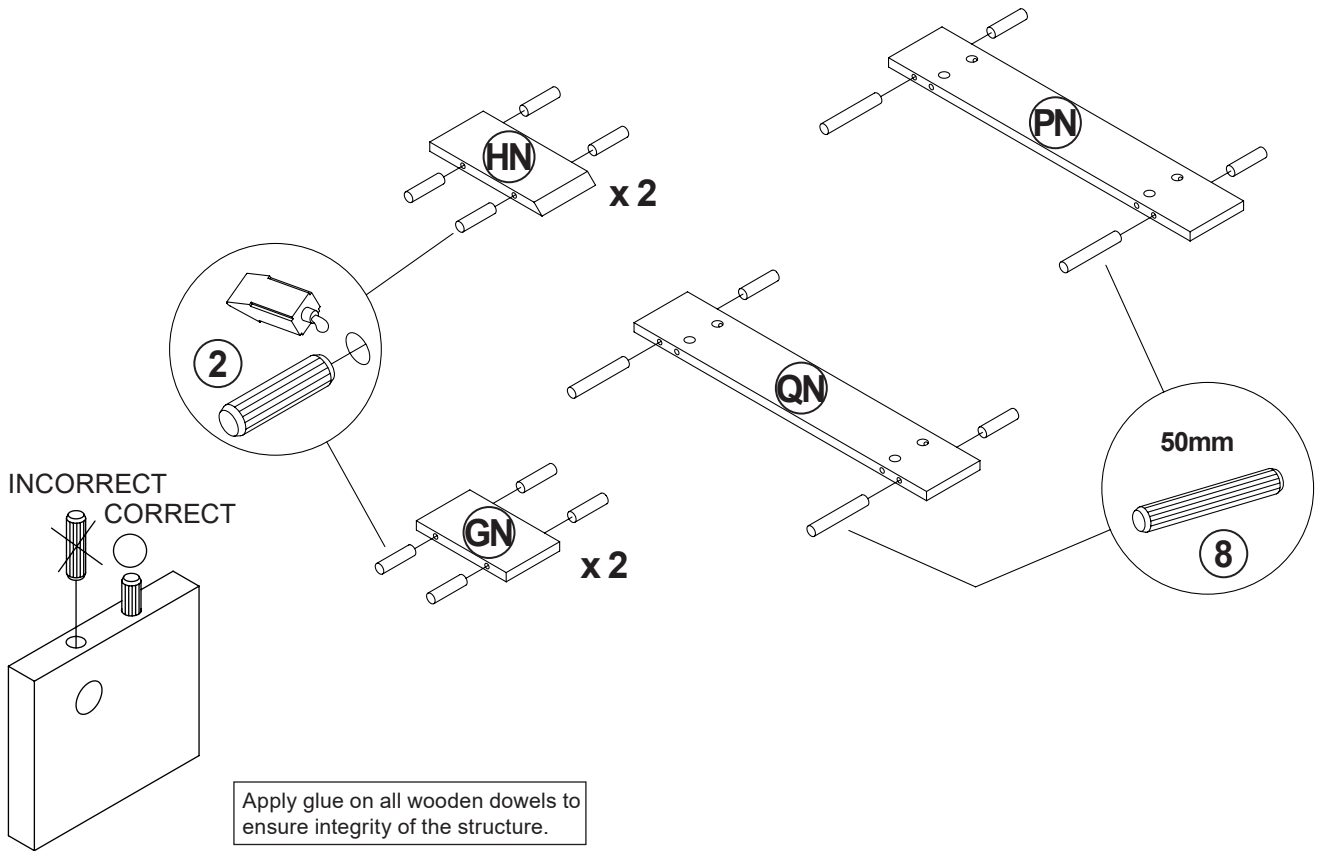
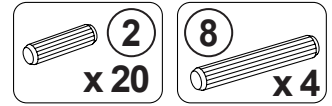

STEP 2

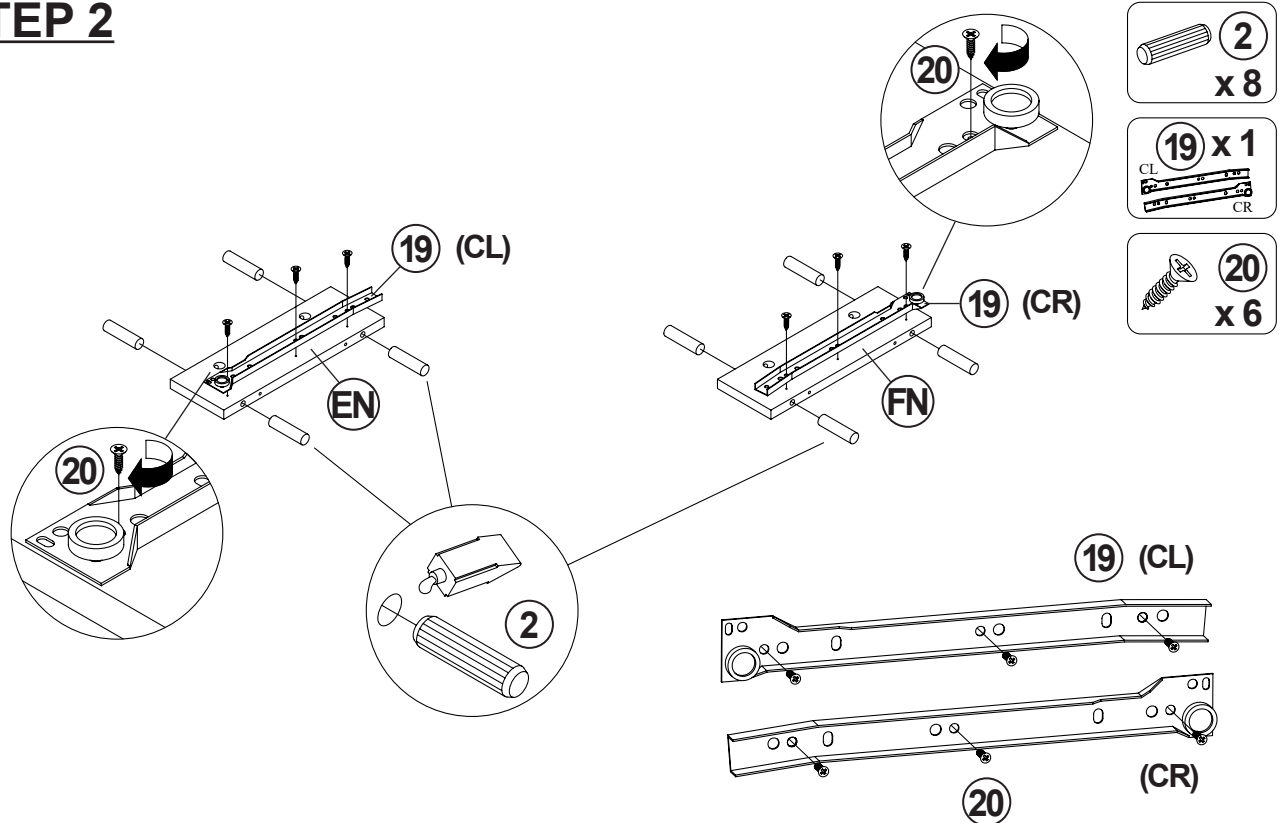

ITEM: 182303

STEP 3

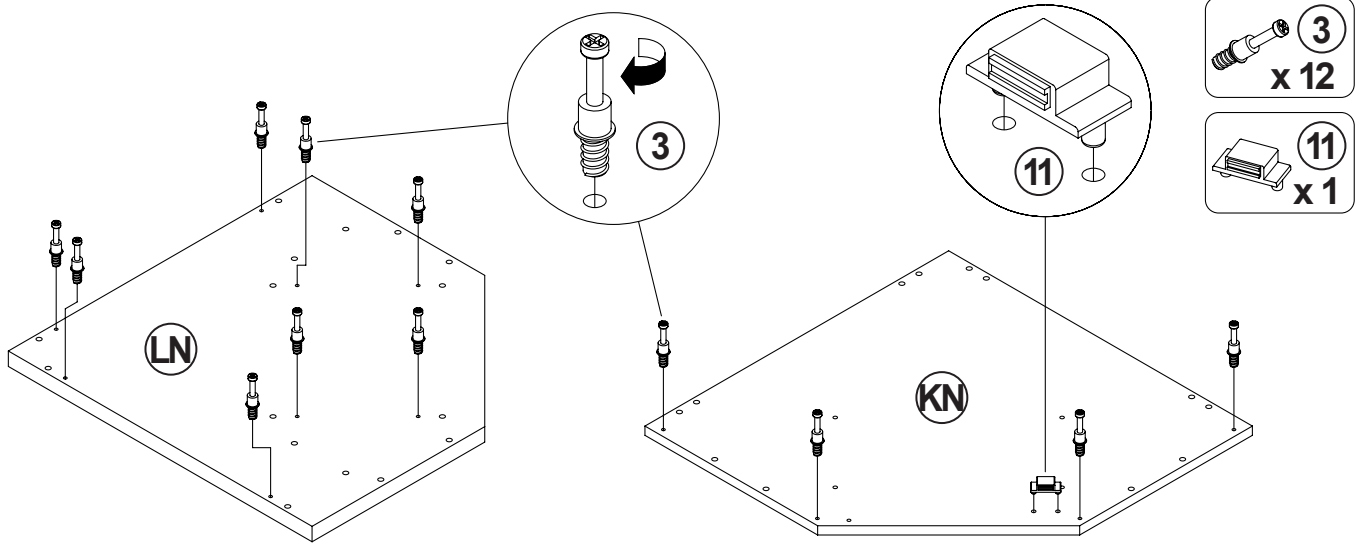

STEP 4

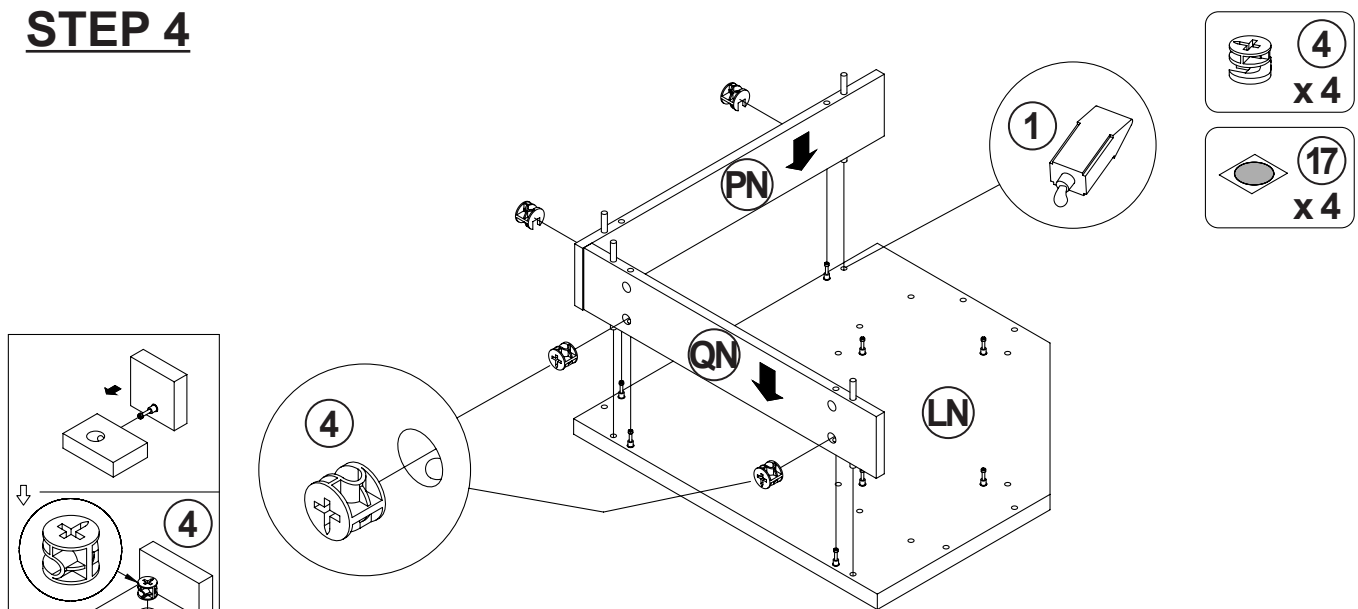

STEP 5

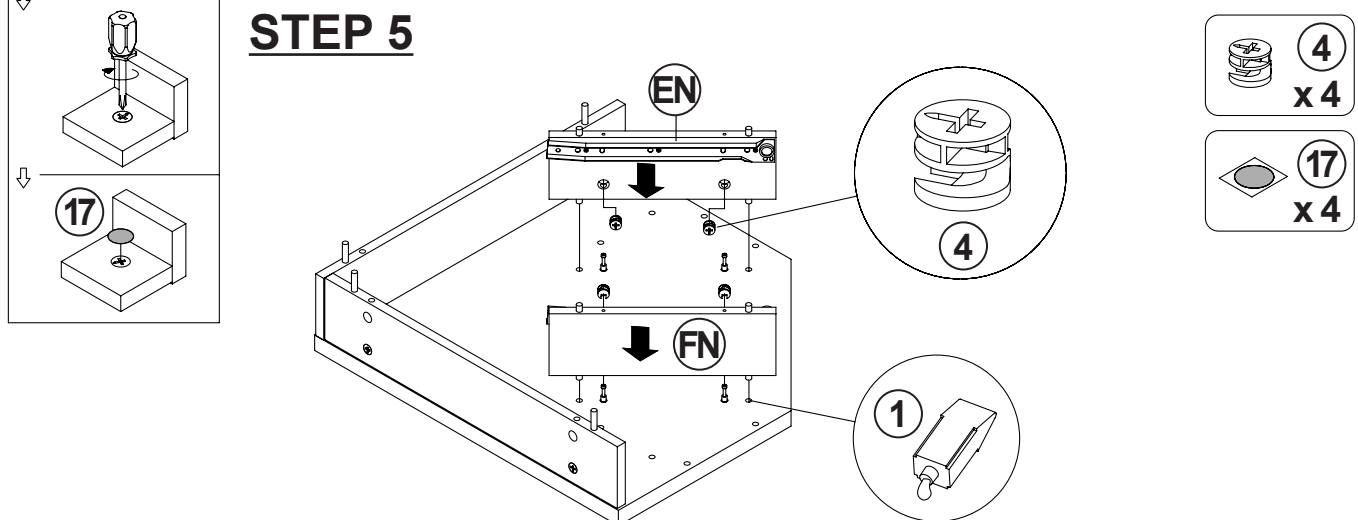

Apply glue on all wooden dowels to ensure integrity of the structure.

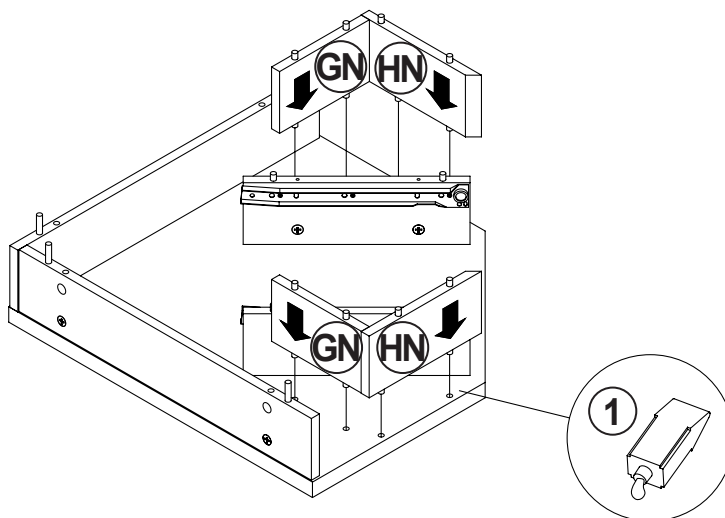

Apply glue on all wooden dowels to ensure integrity of the structure.



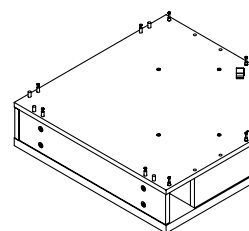
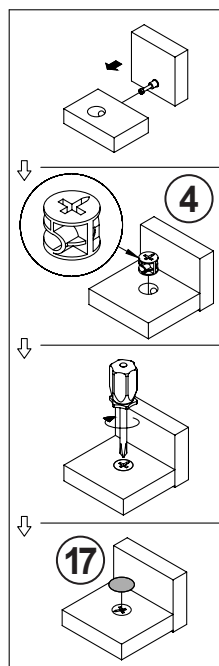
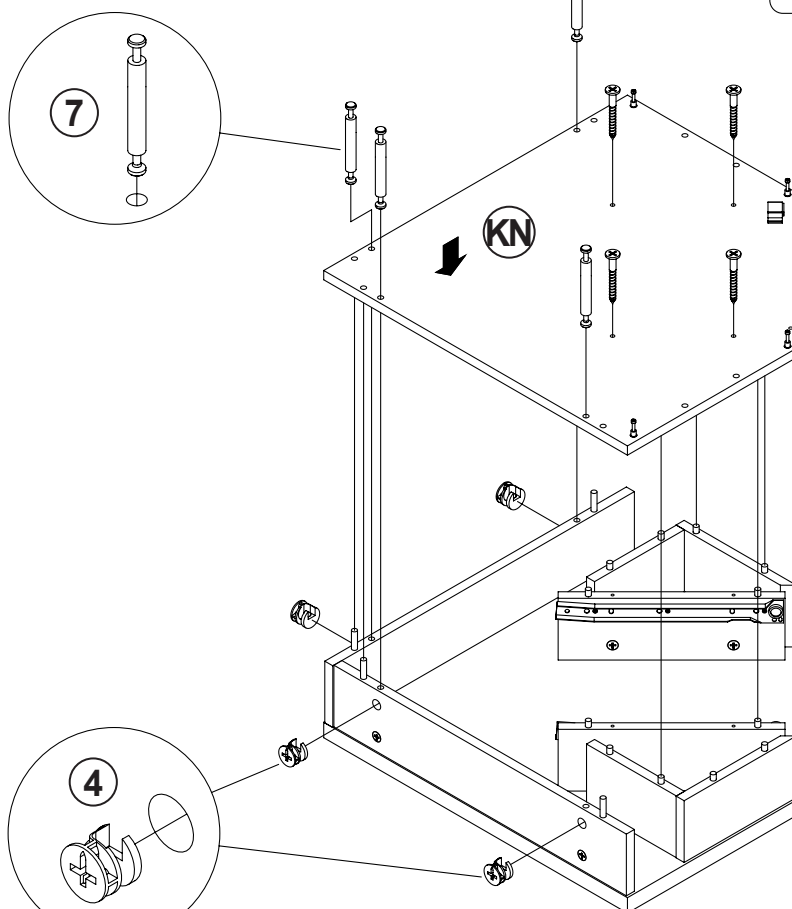

STEP 7

- 4**
x 4
- 5**
x 4
- 7**
x 4
- 17**
x 4





ITEM: **182303**

STEP 8

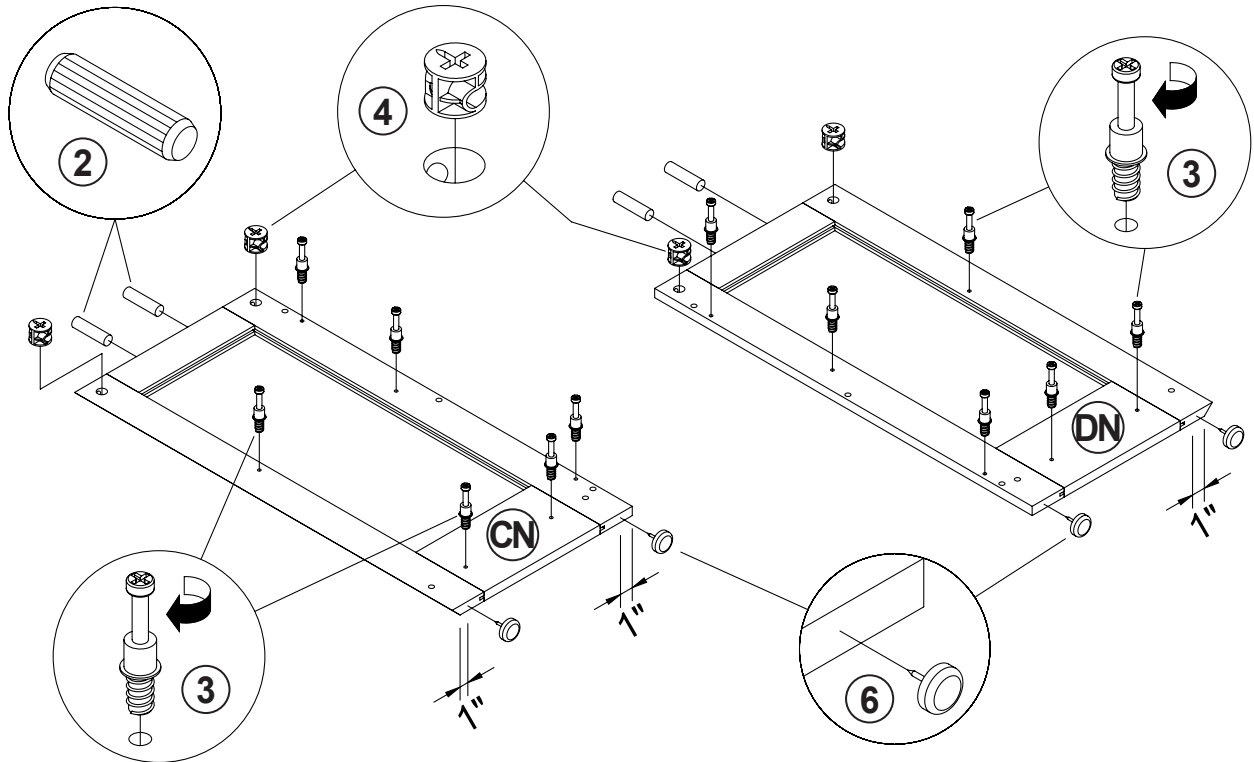
-  **2**
x 4
-  **3**
x 12
-  **4**
x 4
-  **6**
x 4



STEP 9

-  **2**
x 8
-  **3**
x 8
-  **6**
x 4

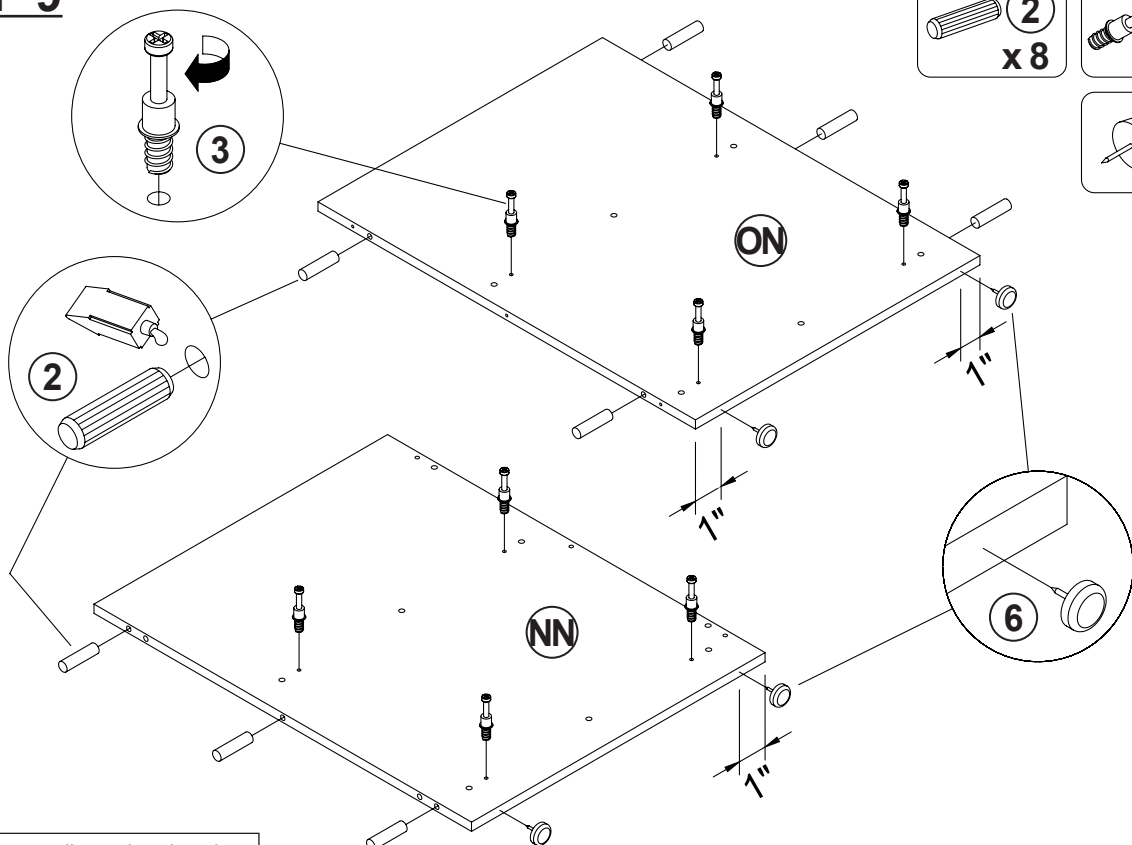

Apply glue on all wooden dowels to ensure integrity of the structure.

ITEM: **182303**

STEP 10

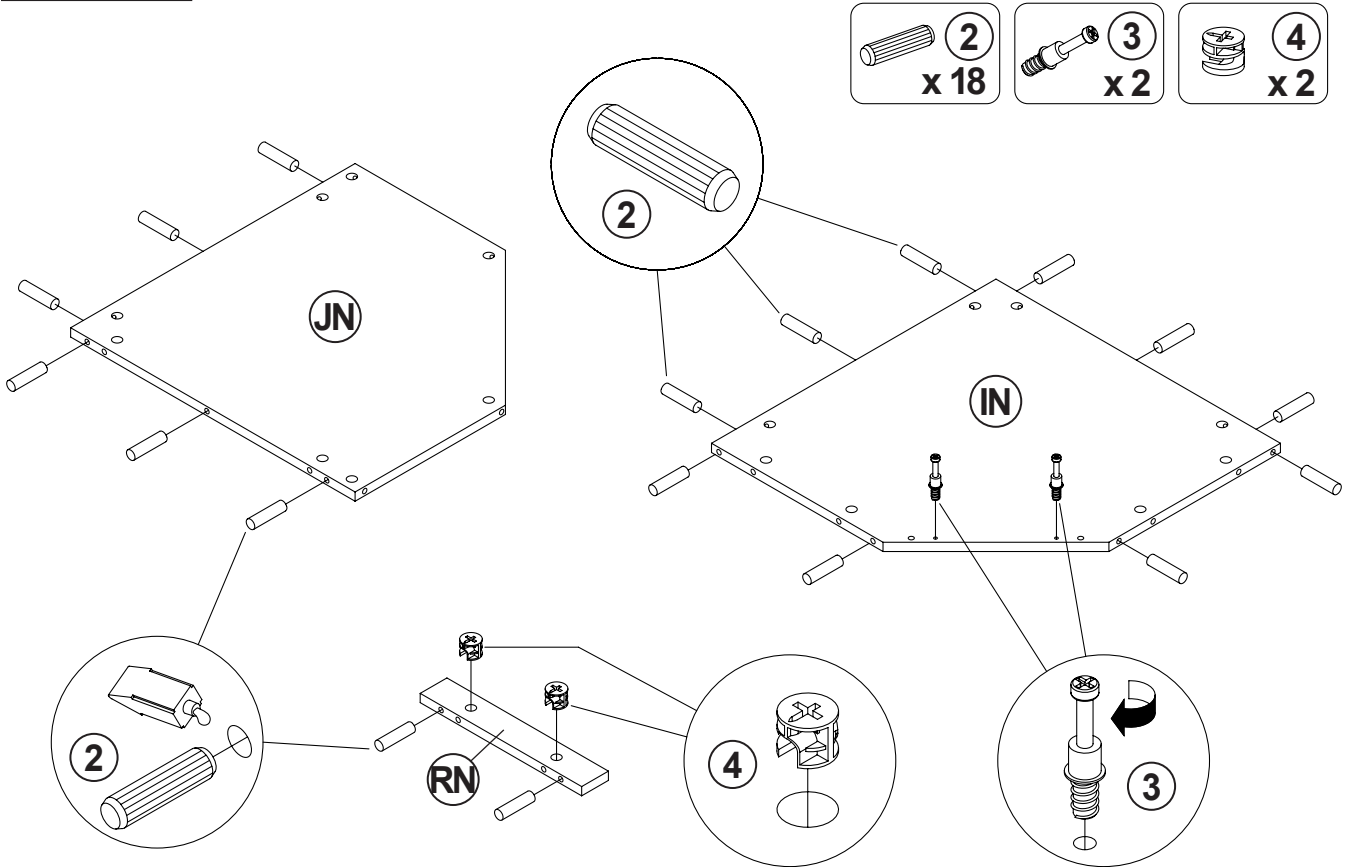

STEP 11

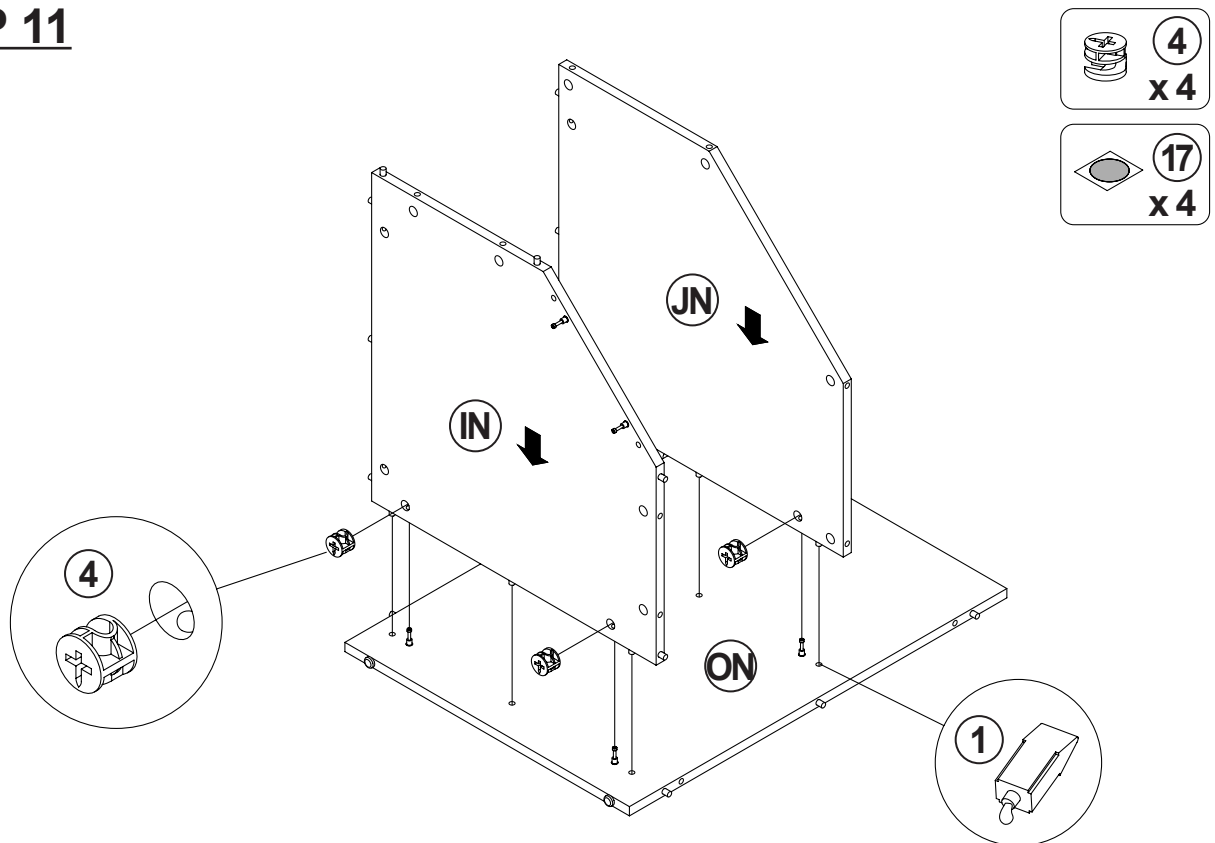

Apply glue on all wooden dowels to ensure integrity of the structure.

ITEM: **182303**

STEP 12

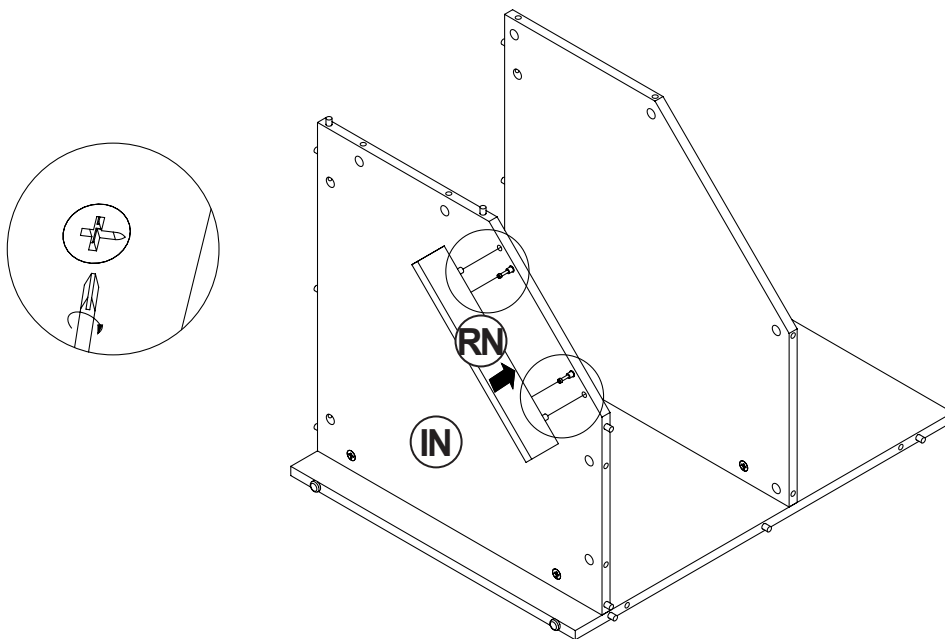
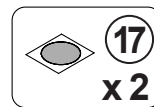

STEP 13

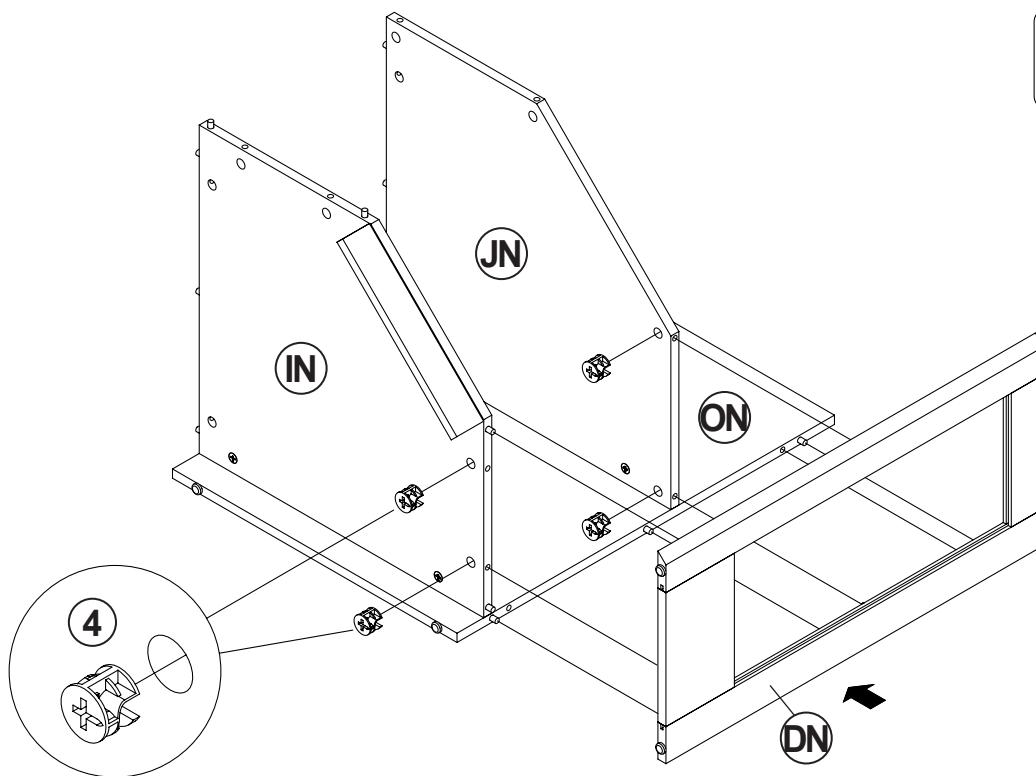
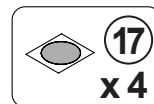

ITEM: **182303**

STEP 16

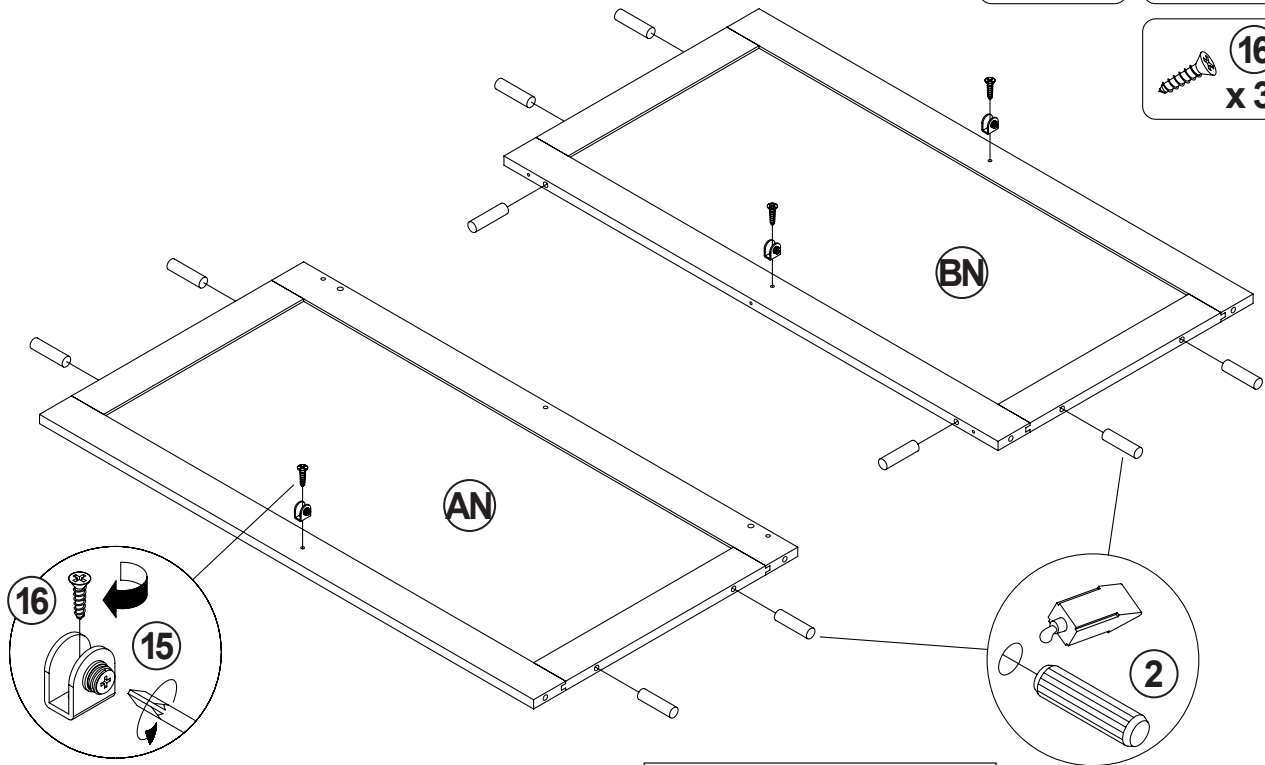
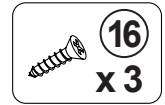
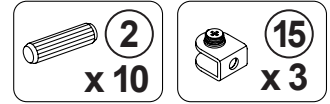

Apply glue on all wooden dowels to ensure integrity of the structure.

STEP 17

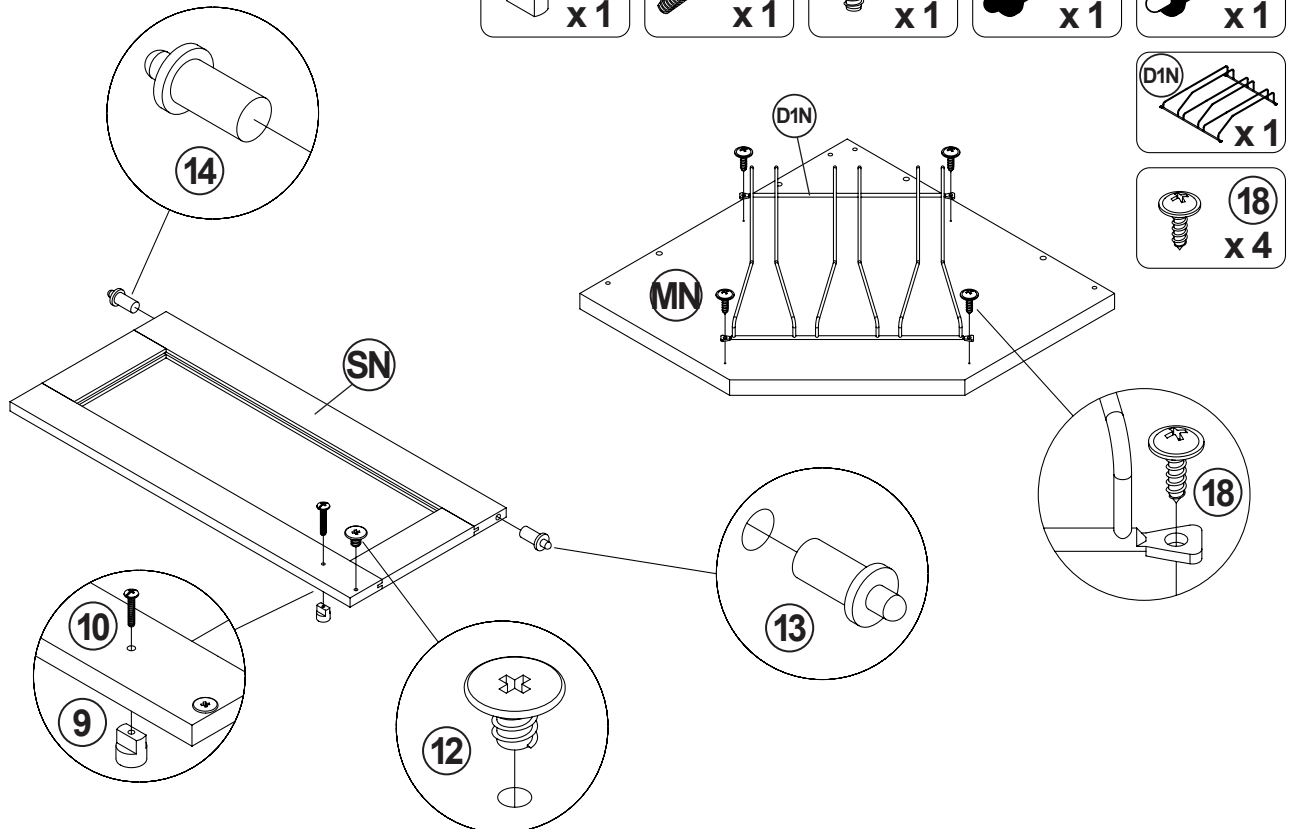
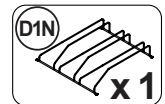
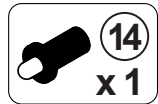
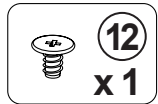
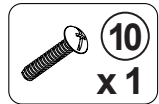
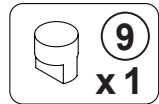

ITEM: **182303**

STEP 18

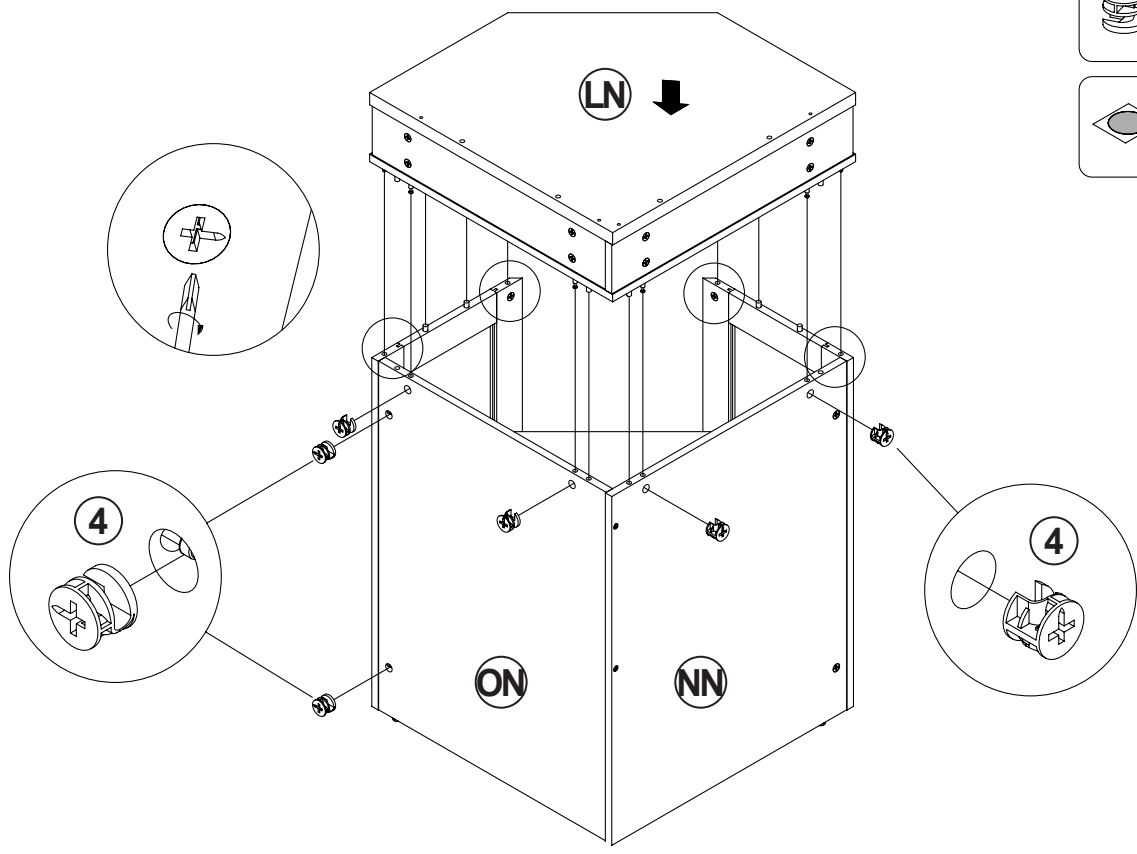

STEP 19

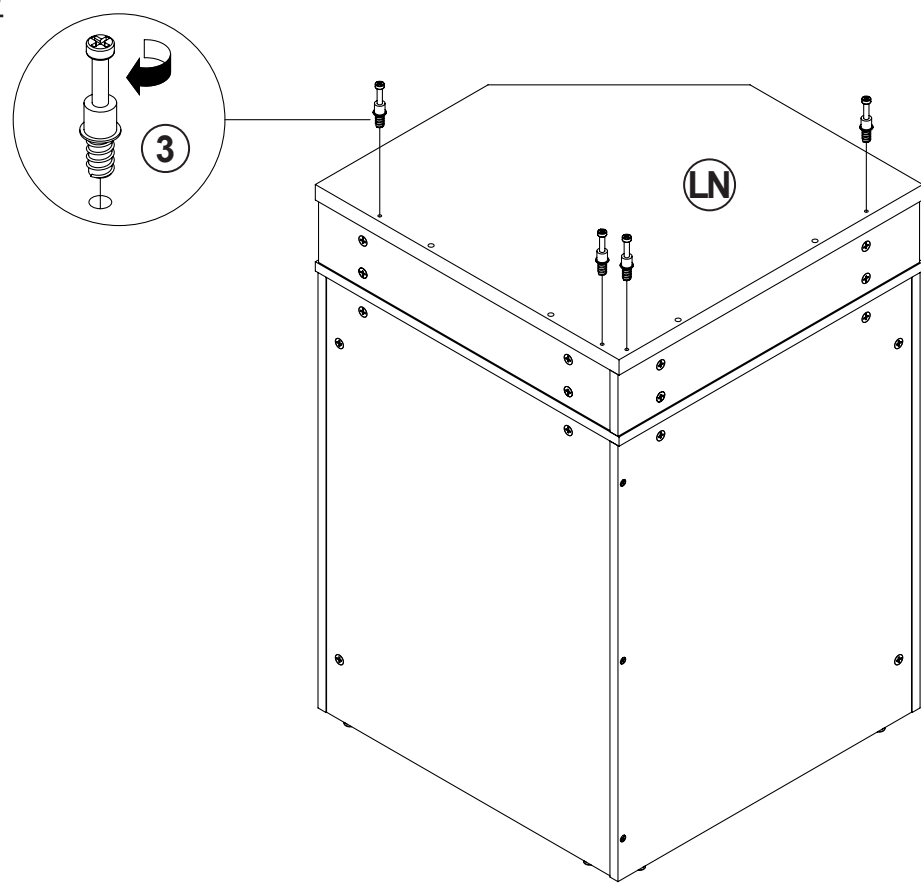

ITEM: **182303**

STEP 22

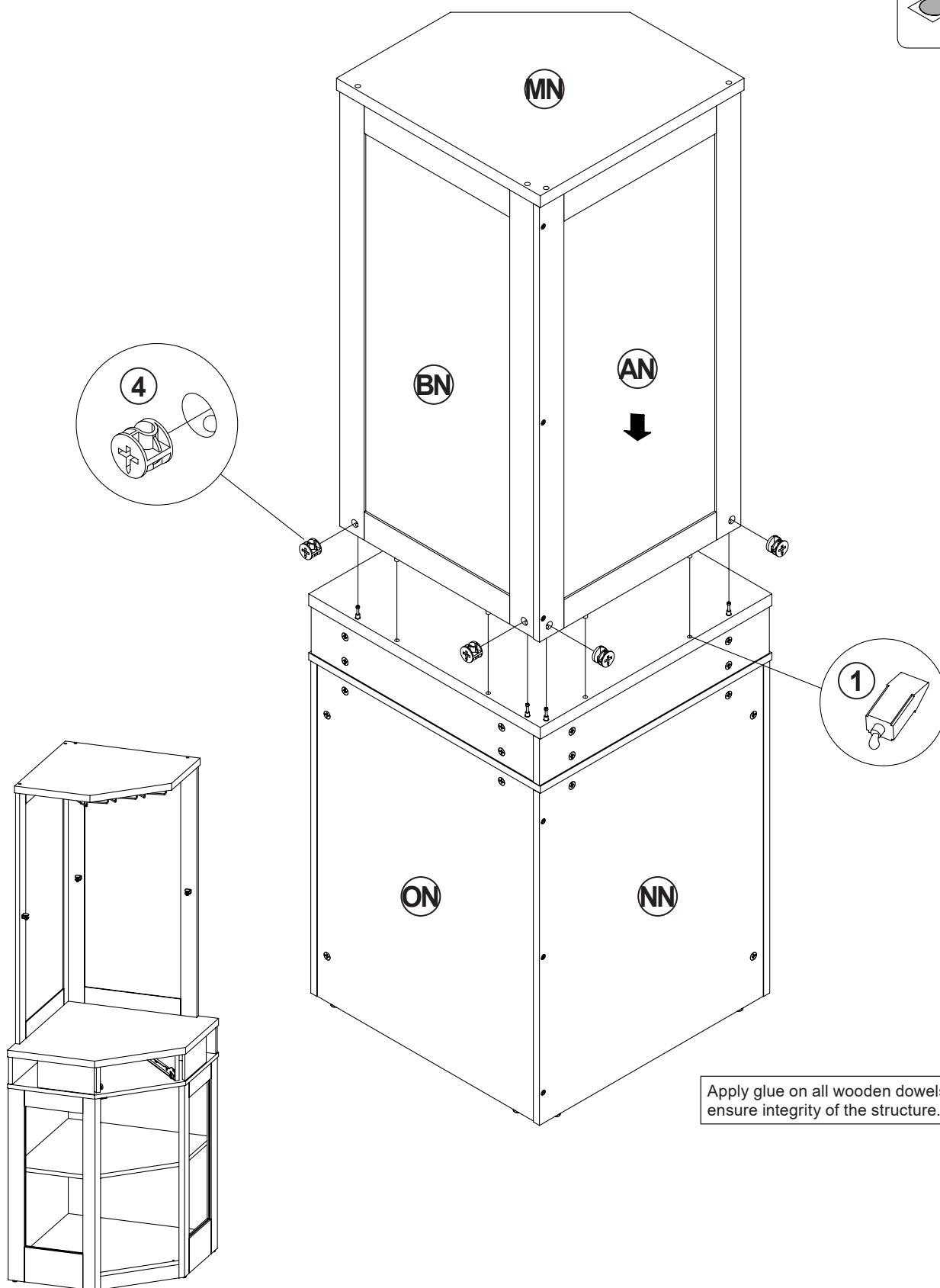
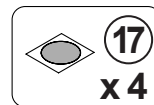

Apply glue on all wooden dowels to ensure integrity of the structure.

ITEM: 182303

STEP 23-1

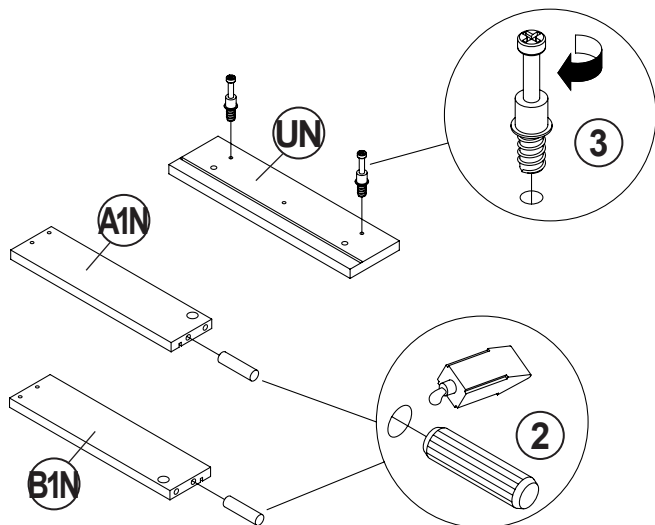

STEP 23-2

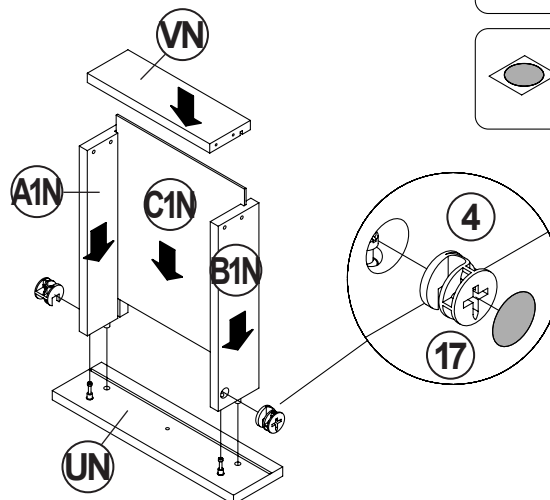

STEP 23-3

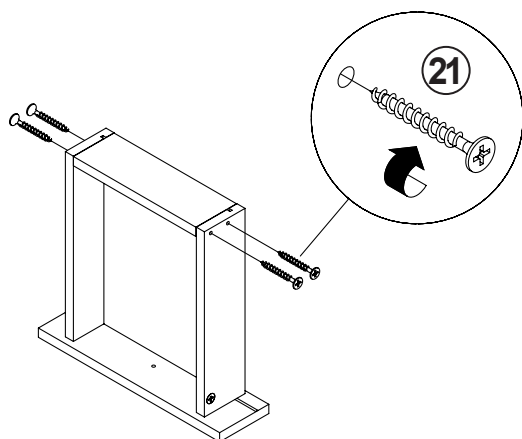
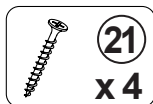

STEP 23-4

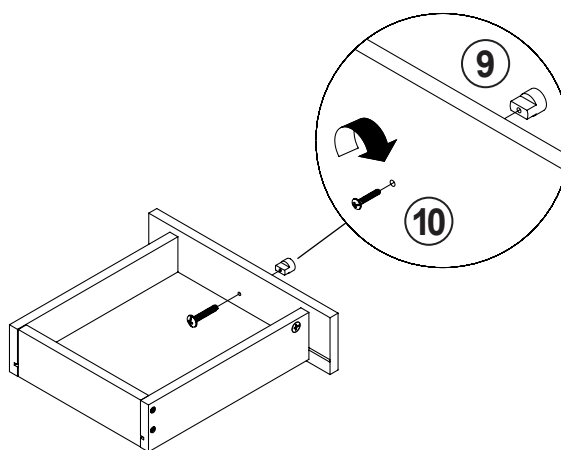
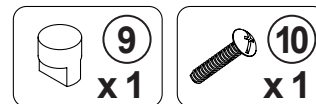

STEP 23-5

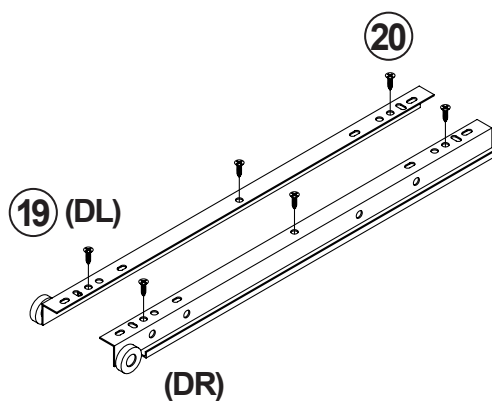
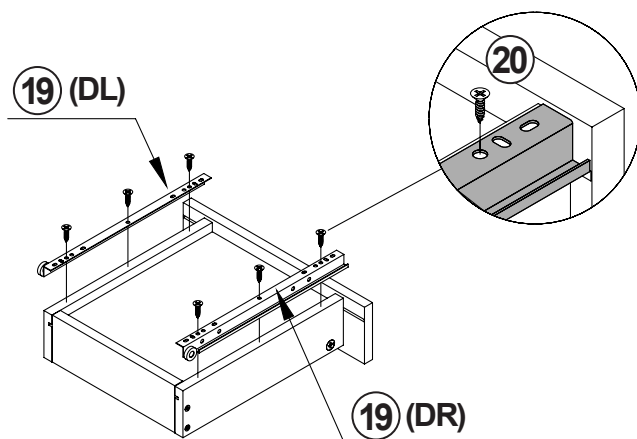
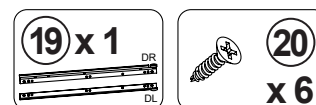

ITEM: **182303**

STEP 24

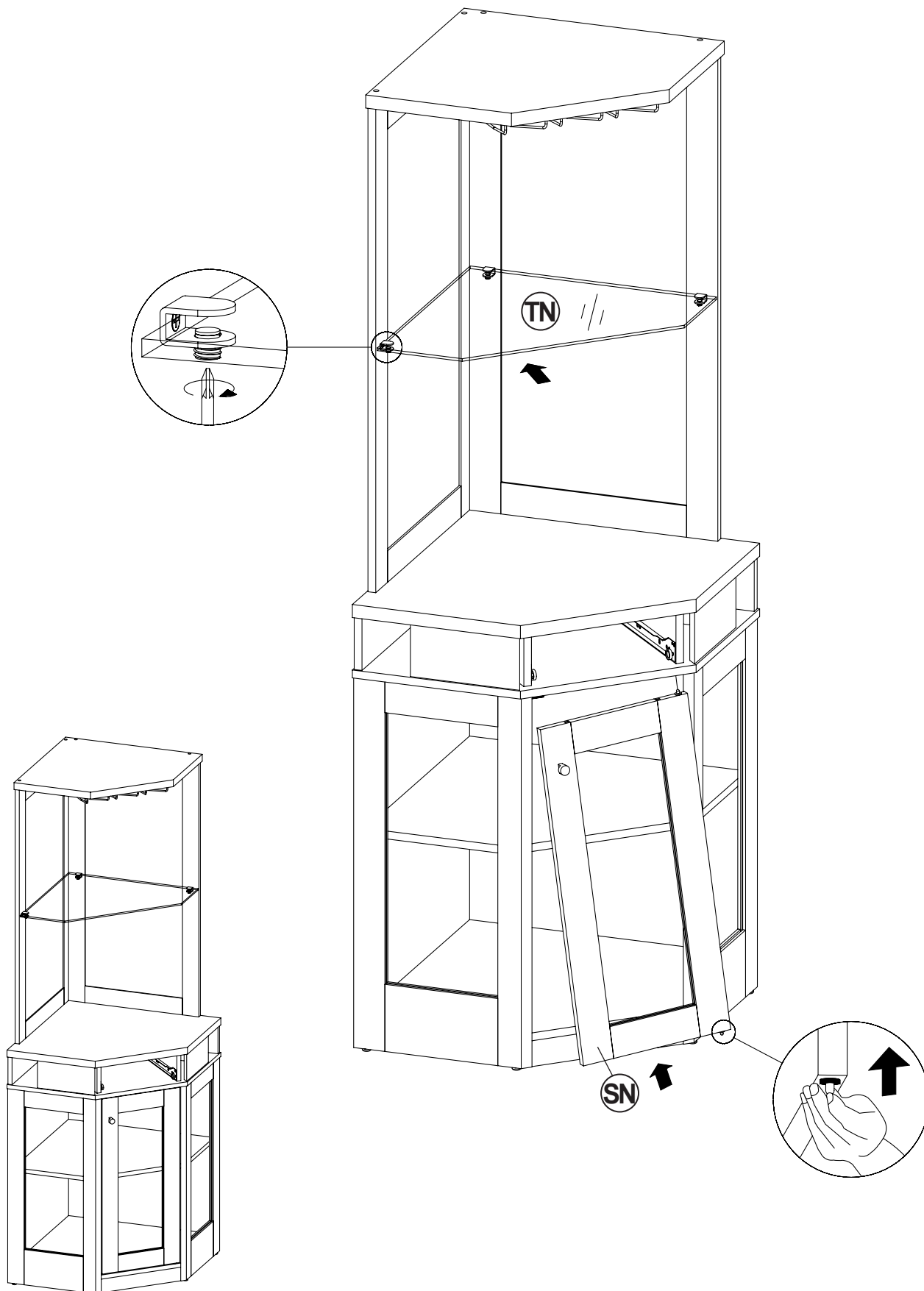

ITEM: **182303**

STEP 25

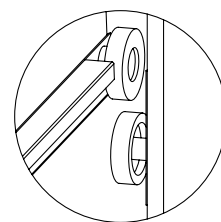
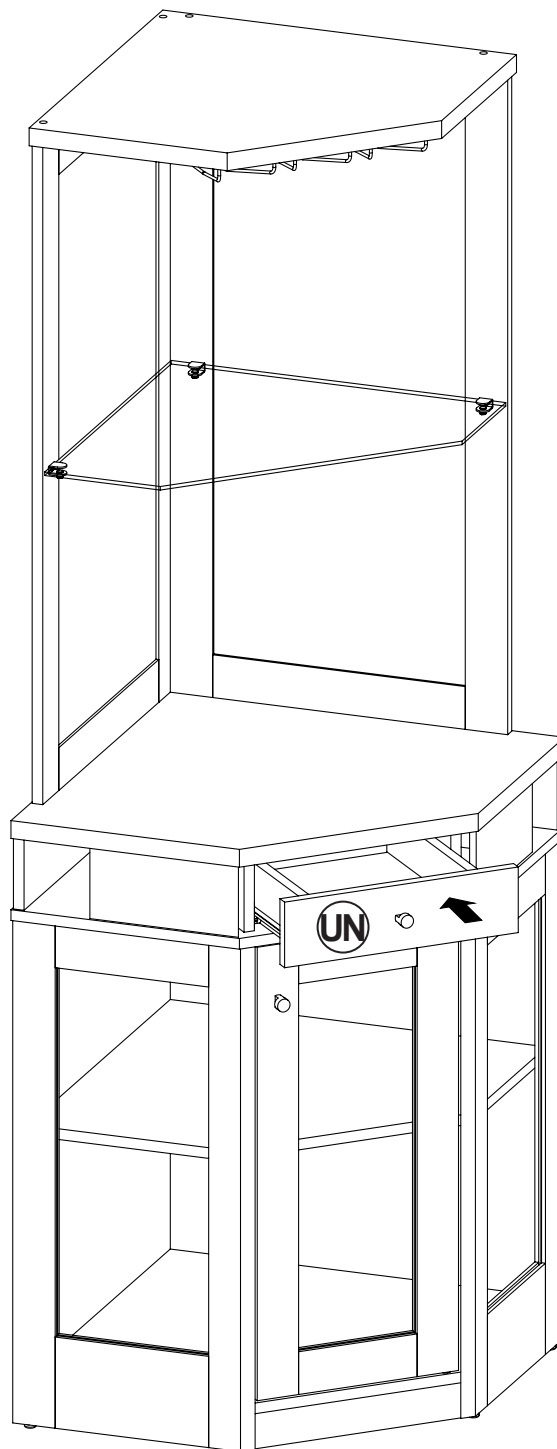

COMPLETE

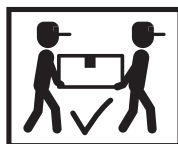
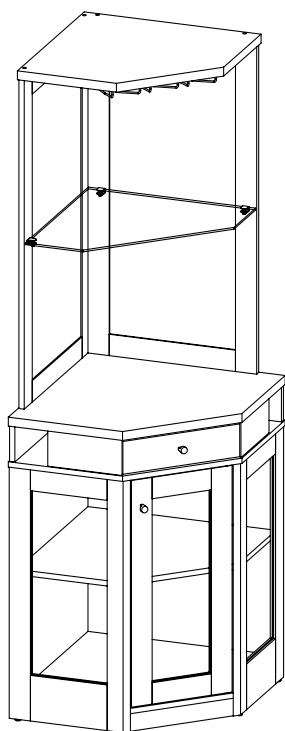

ITEM: 182303

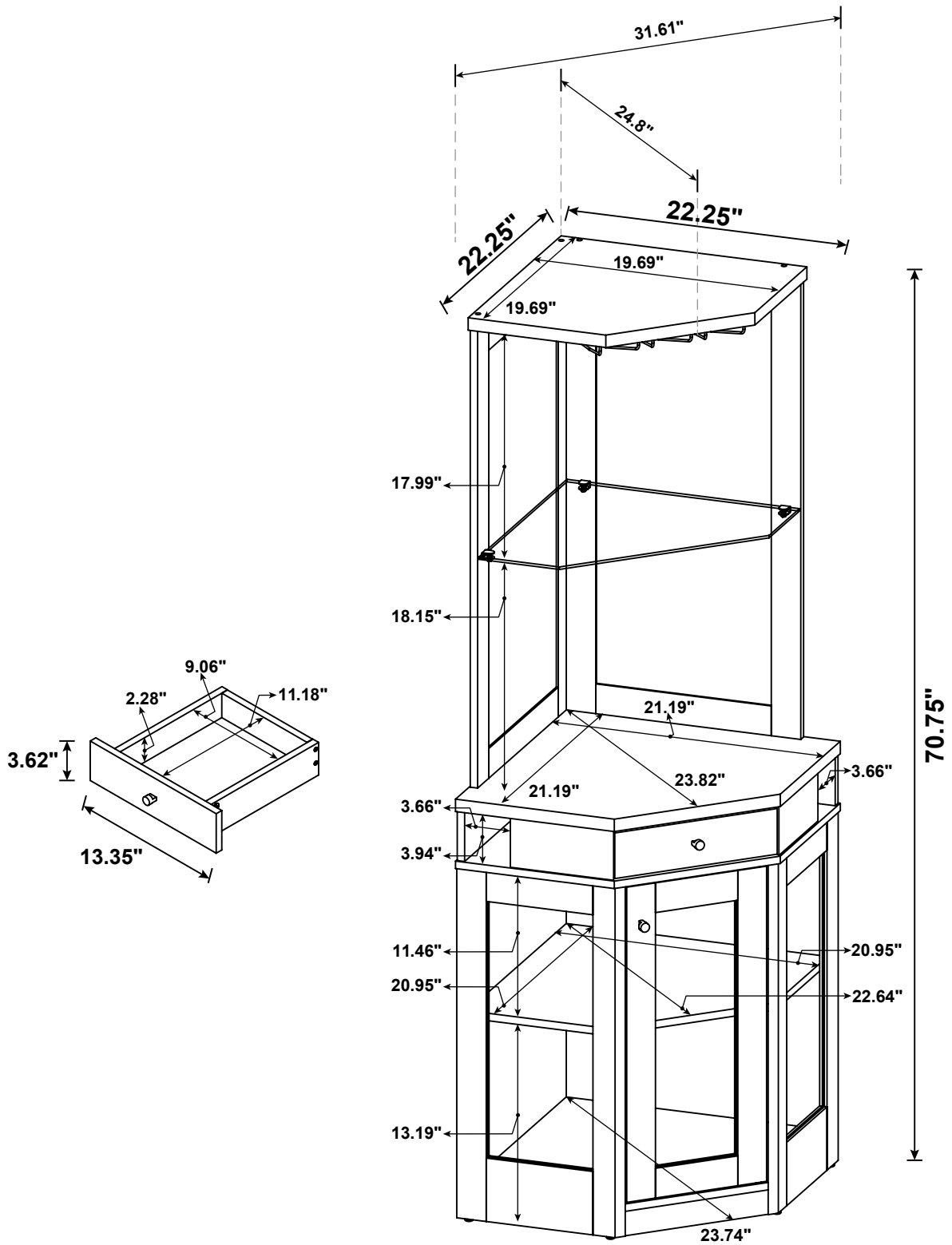

Note : Dimension tolerance $\pm 5\%$

ANTI-TIPPING INSTALLMENT INSTRUCTIONS

FURNITURE TIPPING RESTRAINT

WARNING

Injury may result from tipping furniture.
This restraint may protect against tipping furniture.
Do not allow children to climb on furniture.
This restraint is not a substitute for proper adult supervision.
Failure to detach this restraint before moving the furniture
may result in injury and damage.

1. To attach the anti-tip strap, securely mount one end to the top of the case piece with the 5/8" screw.
2. Position the case piece against the wall in the desired location.
3. Pull the anti-tip strap taut and mark the position of where you will secure the other end on the wall.
4. Drill a 1-1/4" hole in the spot you marked.
5. Tap in plastic wall plug.
6. Fasten anti-tip strap with wall screw provided.

(Please install the anti-tipping kit in the middle of the case piece if only have one set of anti-tipping kit.)

