

LINQ™ 6821

DESK

INSTRUCTION MANUAL

LET'S GET STARTED.

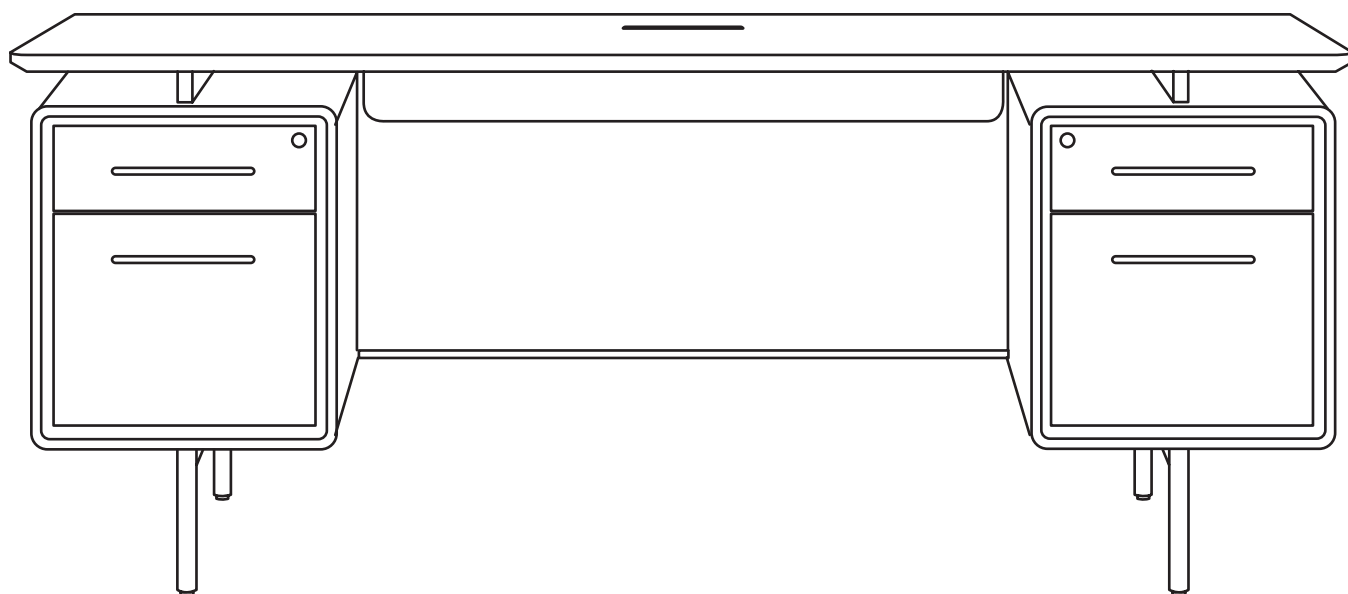

DESIGN MATTHEW WEATHERLY

BDi

BDIUSA.COM

Congratulations on the purchase of your LINQ desk from BDI. Your desk has been designed to provide a lifetime of enjoyment. This manual will provide assembly instructions and other helpful information to ensure you get the most out of your product. Please save it for future reference.

Your LINQ has been engineered for simple assembly. Please follow these directions carefully to prevent any damage.

Should you need further assistance, contact BDI at customerservice@bdiusa.com.

ENJOY!



HARDWARE AND COMPONENTS

Unpack and identify the parts listed below. The assembly workspace should be a non-marring surface, such as carpet. For missing hardware pieces, please contact BDI Customer Service at customerservice@bdiusa.com. For all other concerns, please contact your BDI retailer.

Do not use power tools for the assembly of this product.

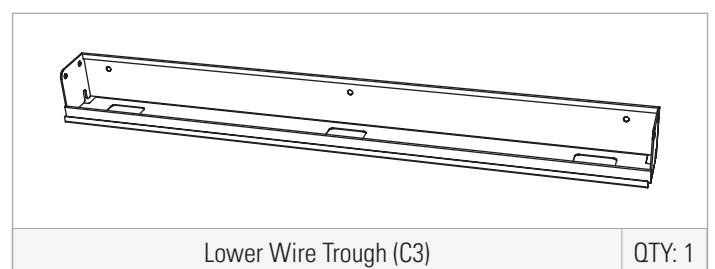
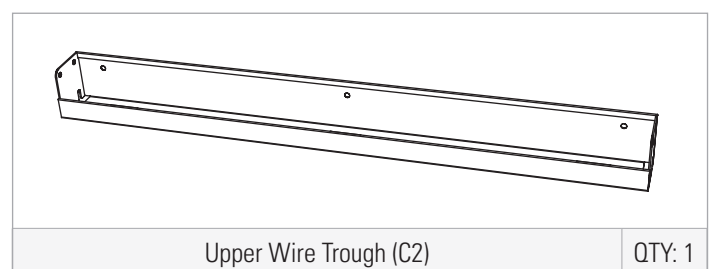
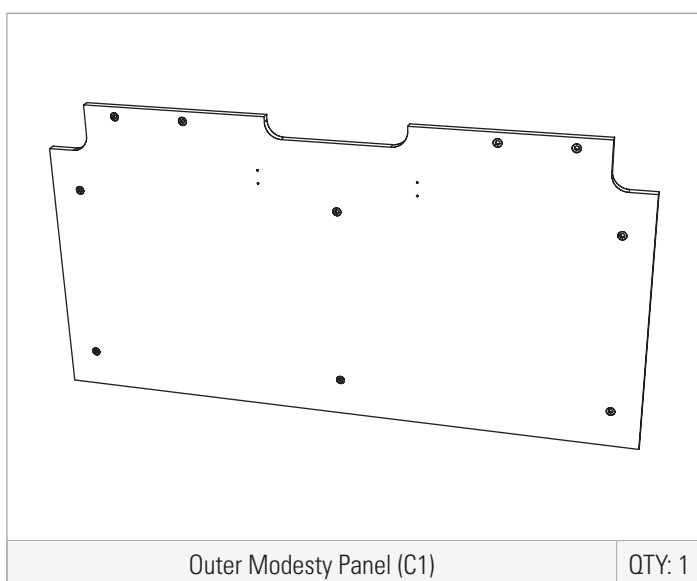
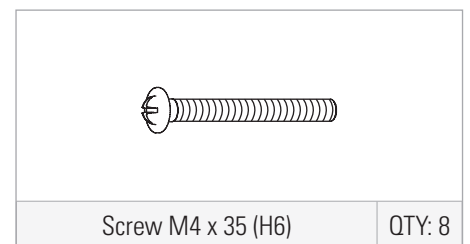
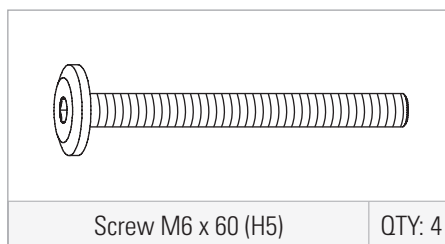
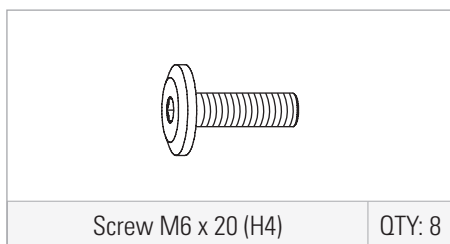
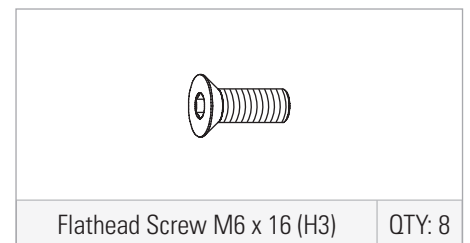
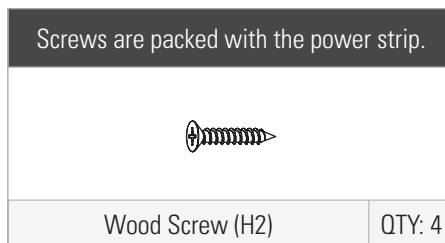
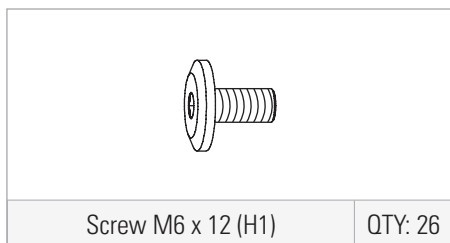
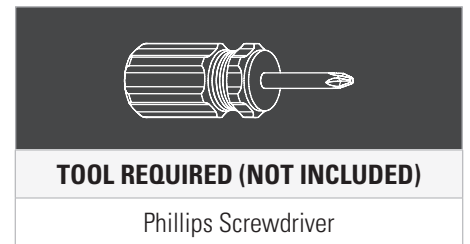
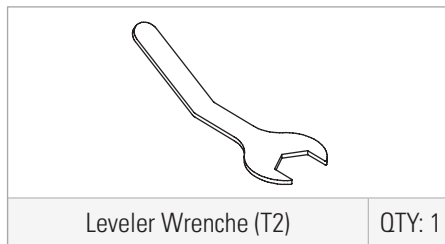
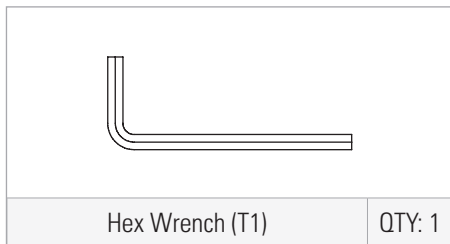

HARDWARE AND COMPONENTS



Modesty Panel Bracket (C4)

QTY: 2

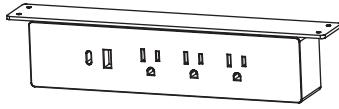

Power Strip (C5)

QTY: 1



Standoff (C6)

QTY: 4

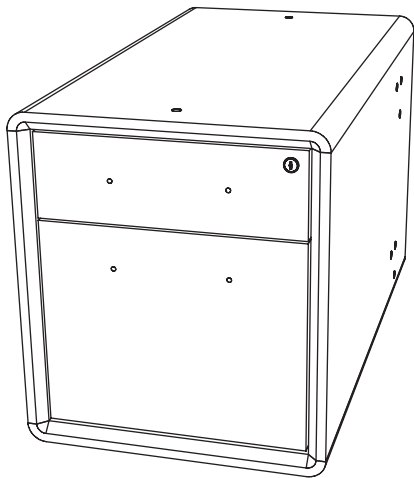

Left Cabinet (C7)

QTY: 1

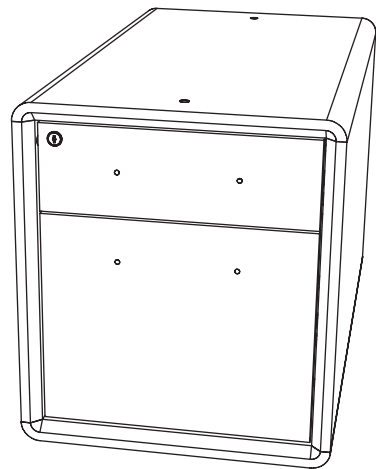

Right Cabinet (C8)

QTY: 1

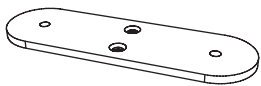

Leg Plate (C9)

QTY: 4

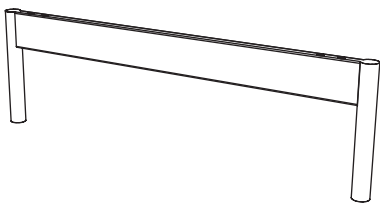

Leg (C10)

QTY: 2

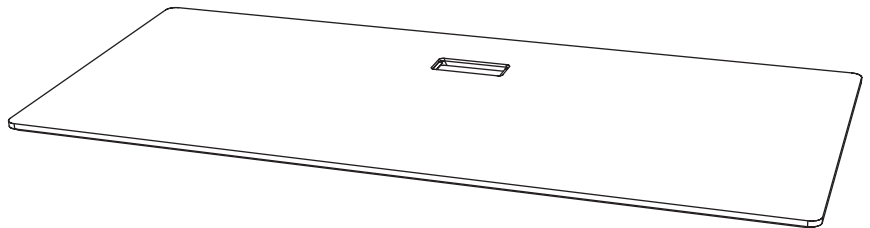

Top Panel (C11)

QTY: 1

HARDWARE AND COMPONENTS

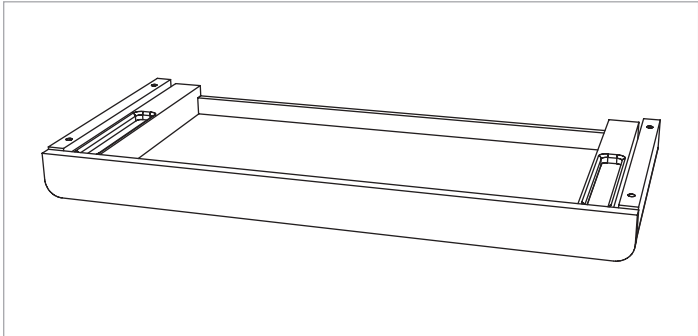

Keyboard Drawer (C12) QTY: 1

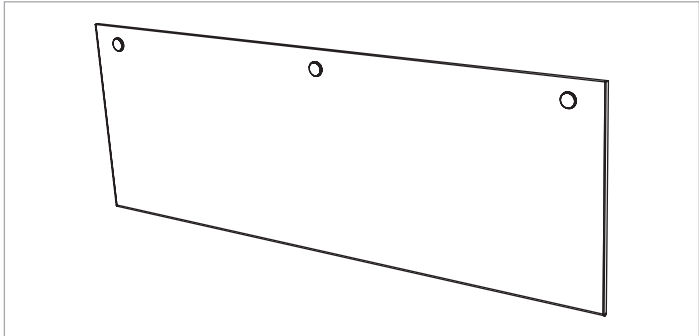

Inner Modesty Panel (C13) QTY: 1

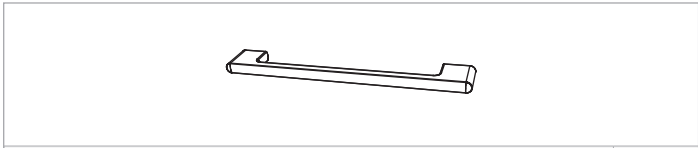

Drawer Pull (C14) QTY: 4

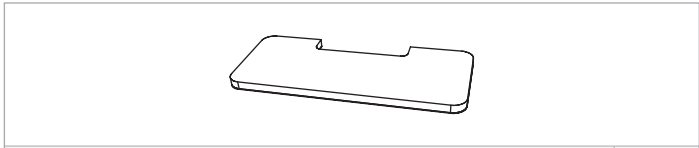

Grommet Lid (C15) QTY: 1

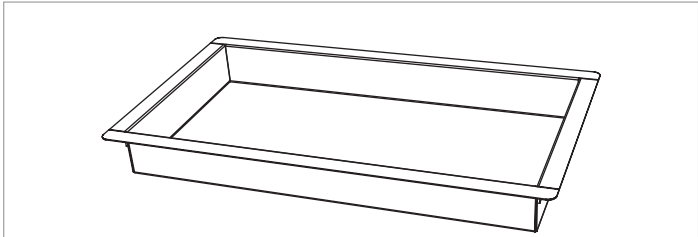

Drawer Tray (C16) QTY: 1

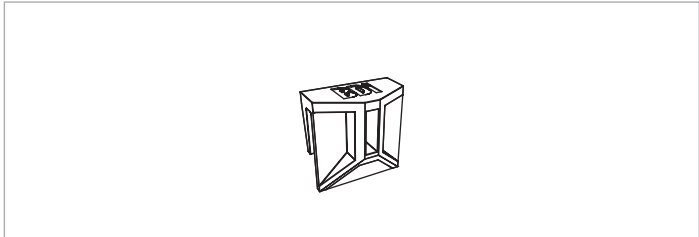



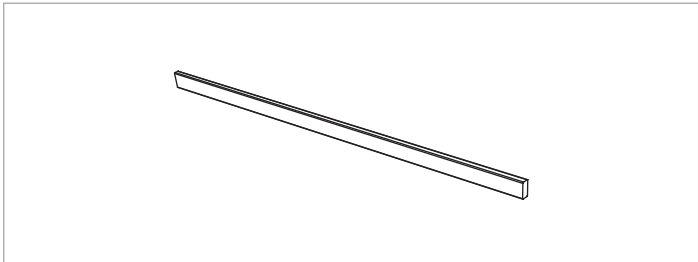

File Clip (C17) QTY: 4



File Hanging Bar (C18) QTY: 2

Attach the **Upper Trough (C2)** and **Lower Trough (C3)** to the **Outer Modesty Panel (C1)** using **6 Screws (H1)**. Attach the **2 Modesty Panel Brackets (C4)** to the **Outer Modesty Panel** using **2 Screws (H1)** per bracket. **Do not fully tighten these screws.**

Tighten **Trough Screws (H1)** with **Hex Wrench (T1)**. Attach the **Power Strip (C5)** using **4 Wood Screws (H2)**. Tighten with **Phillips Screwdriver (not included)**.

	HEX WRENCH – T1	QTY 1
	NOT INCLUDED PHILLIPS SCREWDRIVER	QTY 1
	SCREW – H1	QTY 10
	SCREW – H2 <i>(Packed with Power Strip)</i>	QTY 4

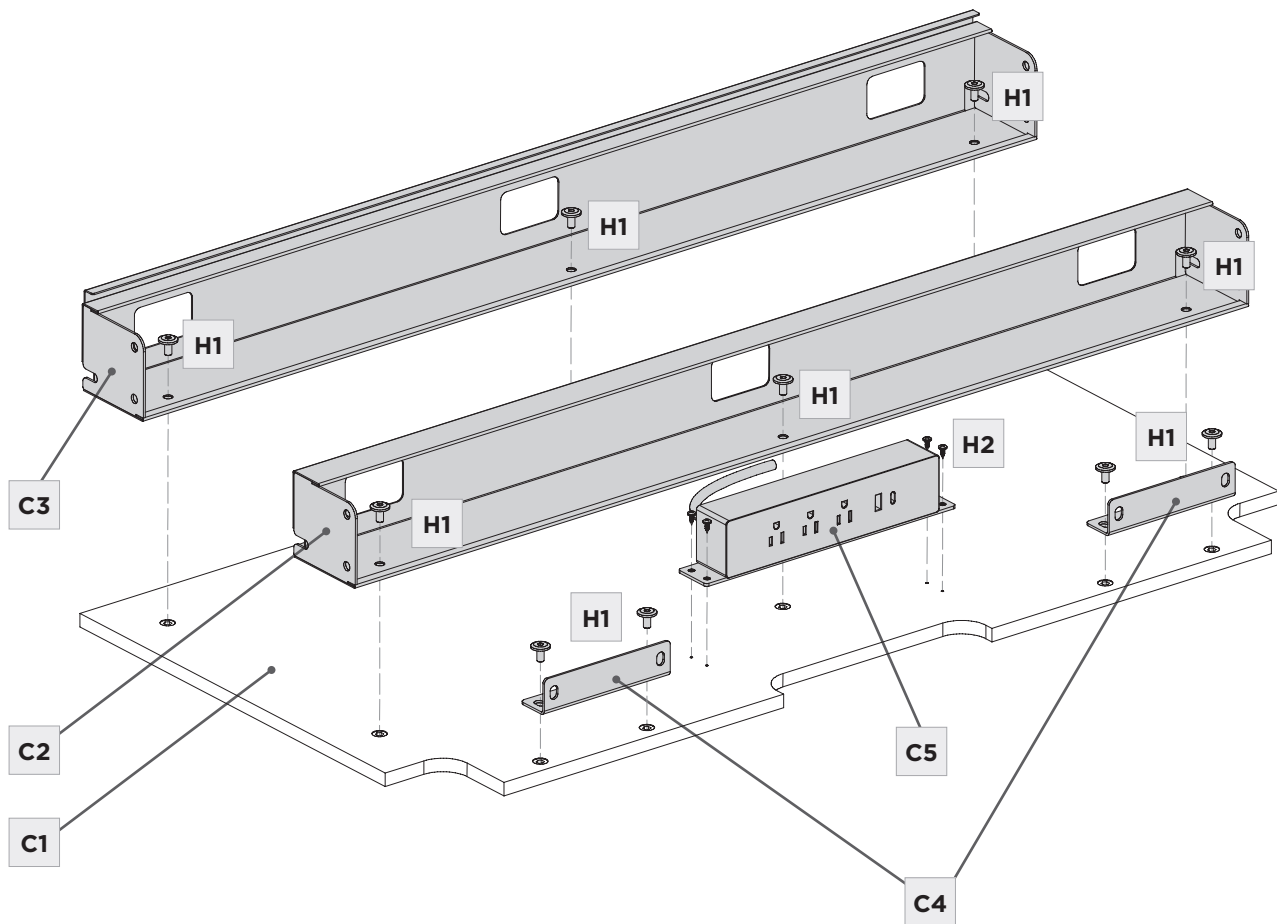

STEP 2. PREPARE CABINETS



ASSEMBLY

Partially thread **4 Screws (H1)** into the lower threaded inserts in each set of 3 threaded inserts of both the **Left Cabinet (C7 and C8)**. Leave about **1/4" (6mm) gap** between the screw head and the cabinet. Install **4 Standoffs (C6)**, threading **2 Standoffs** into the top of each **Cabinet**. Fully Tighten.

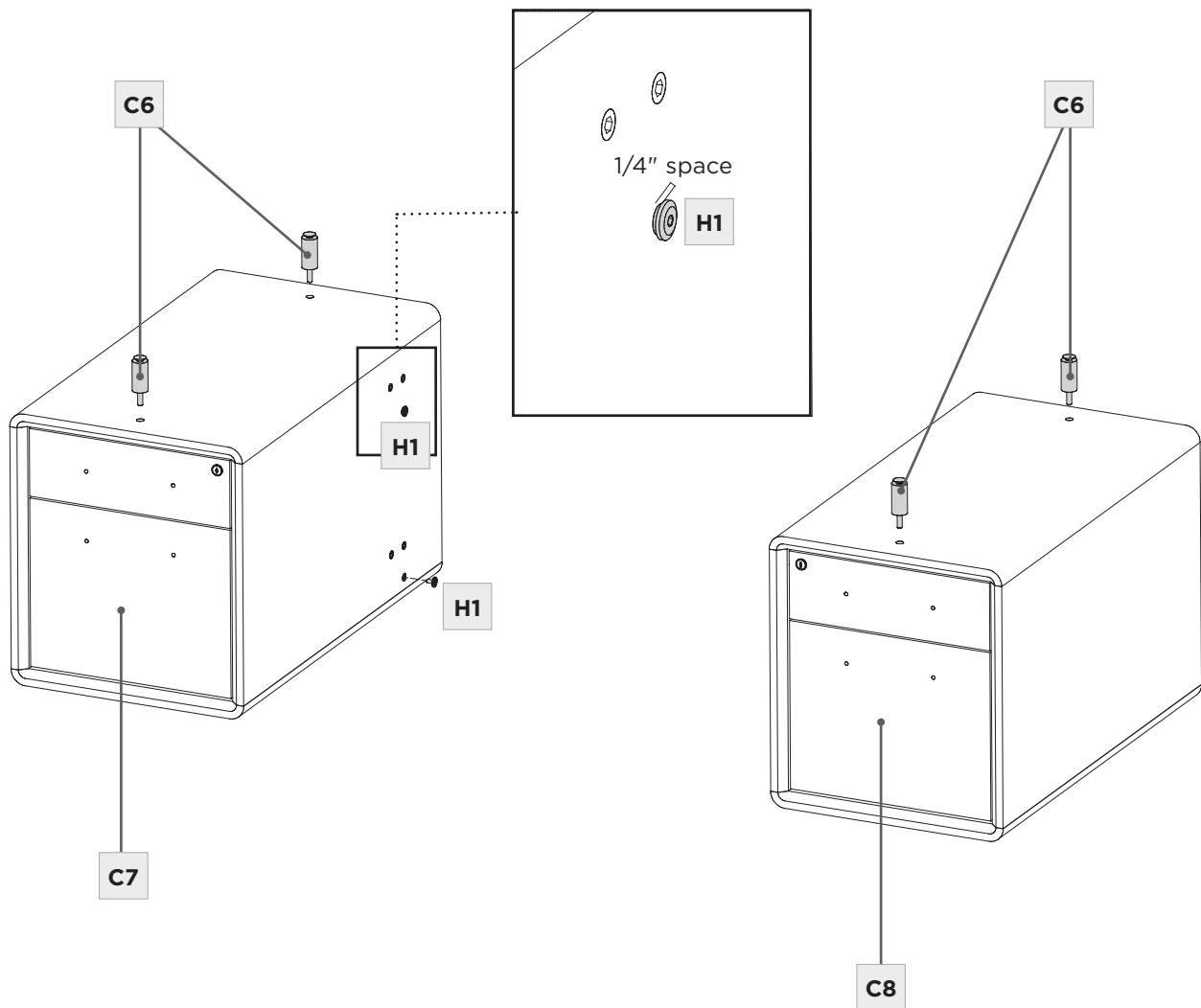
	SCREW – H1	QTY 4
---	------------	----------



Space the **Left Cabinet and Right Cabinet (C7 and C8)** apart, using the **Outer Modesty Panel Assembly** as a guide for spacing. Attach the **Outer Modesty Panel Assembly** by hooking the slotted holes of each **Wire Trough** onto the pre-threaded **Screws (H1)**.

	HEX WRENCH – T1	QTY 1
	SCREW – H1	QTY 8

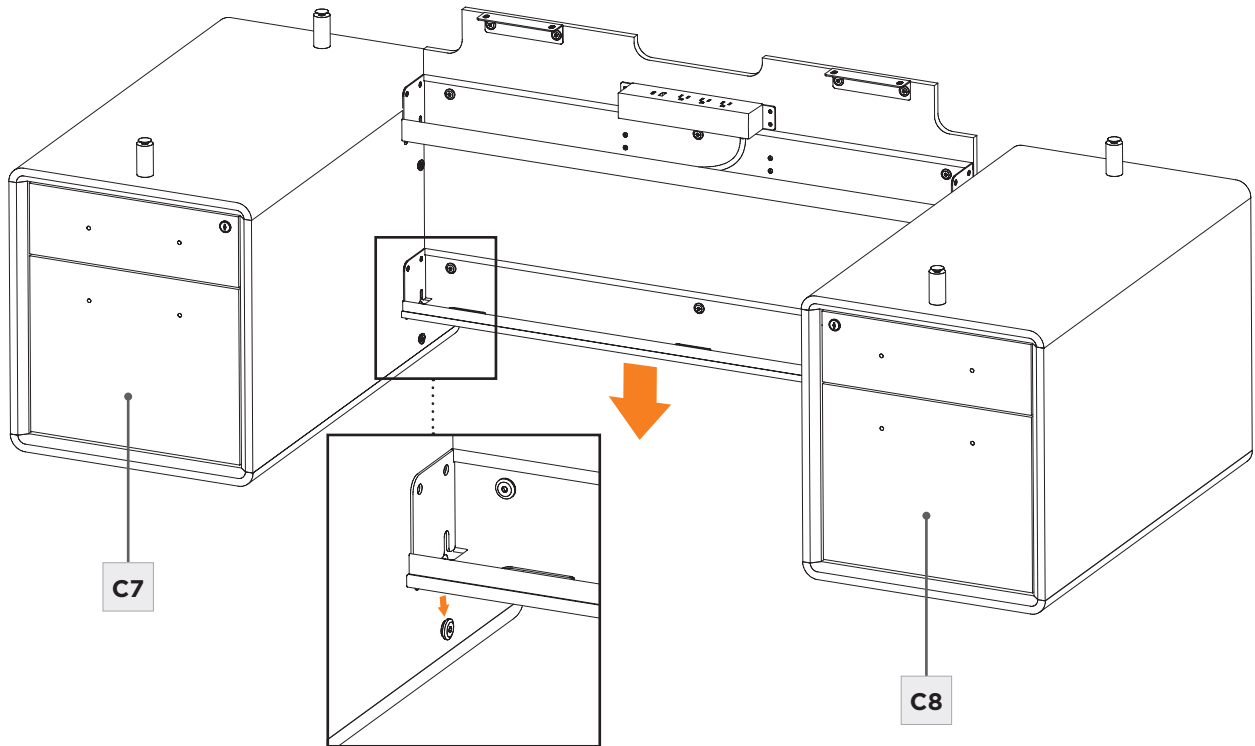

Insert **8 Screws (H1)** to fully secure each **Wire Trough**. Fully tighten all screws with the **Hex Wrench (T1)**.

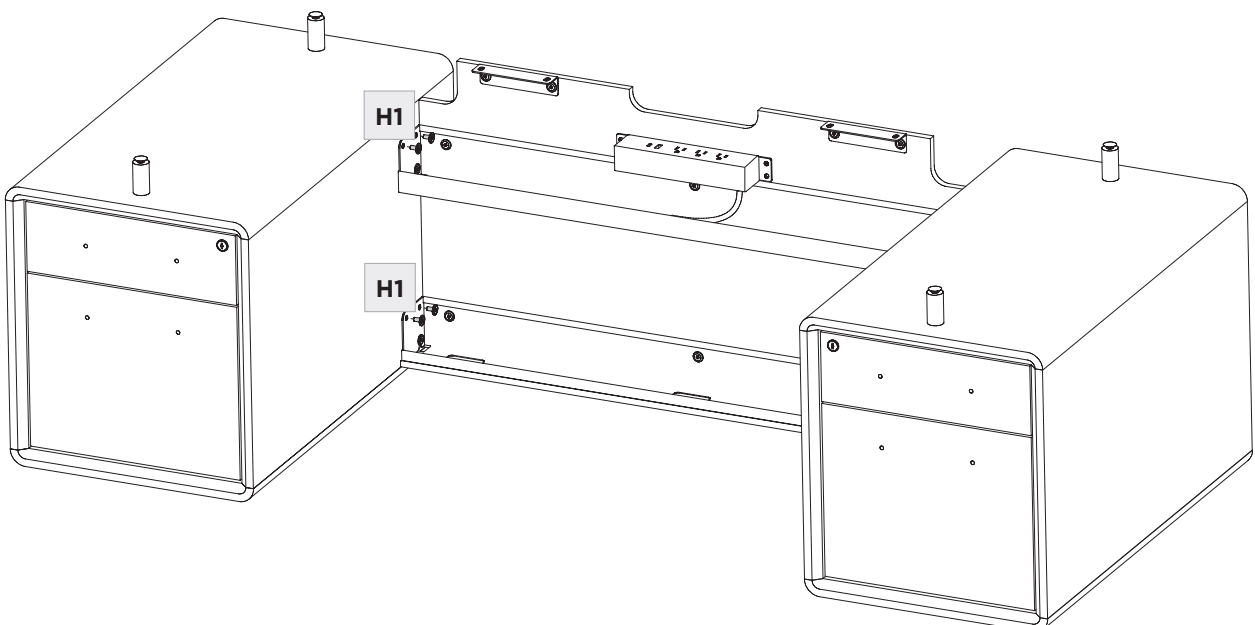

STEP 4. PREPARE LEGS

ASSEMBLY

Attach the **4 Leg Plates (C9)** to the **2 Legs (C10)** using **8 Screws (H3)**. Tighten with **Hex Wrench (T1)**.

	HEX WRENCH – T1	QTY 1
	SCREW – H3	QTY 8

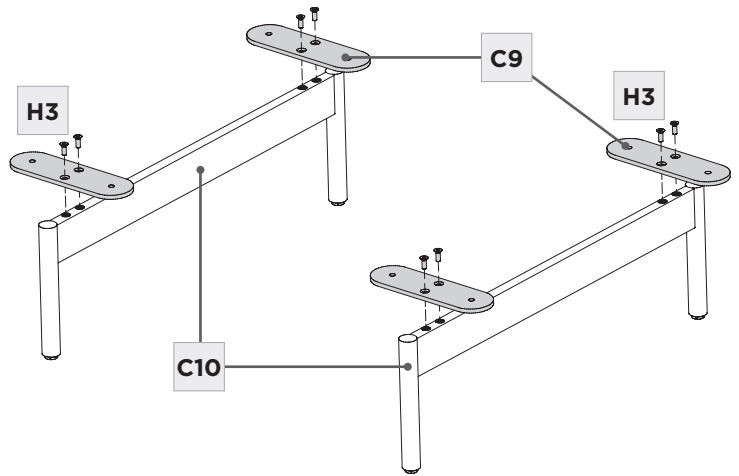

STEP 5. ATTACH LEGS TO CABINETS

ASSEMBLY

With the help of another person, carefully rotate the desk assembly onto its back.

IMPORTANT: Place at least 2" (50mm) of material under each Cabinet. Leftover honeycomb from the packaging works well for this.

Attach each **Leg Assembly** to the underside of each **Cabinet** using **Screws (H4)**. Tighten with the **Hex Wrench (T1)**.

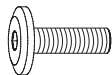
	HEX WRENCH – T1	QTY 1
	SCREW – H4	QTY 8

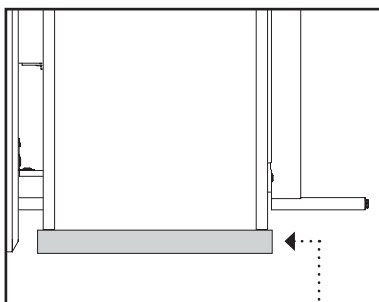

Minimum of 2" (50mm) material under each cabinet

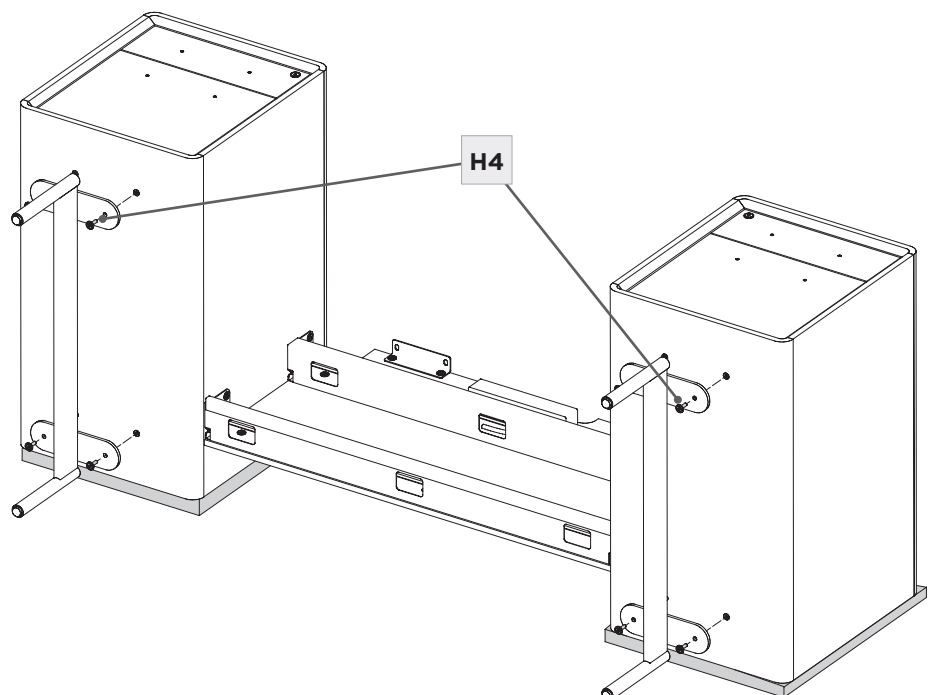

On a non-marring surface, such as carpet, arrange the **Top Panel (C11)**, as shown, so the side with the **Wire Grommet is closer** to the Desk Assembly.

Attach the **Keyboard Drawer (C12)** to the **Top Panel (C11)** with **4 Screws (H5)**. Tighten with **Hex Wrench (T1)**. The **Keyboard Drawer** should be **facing away from the desk**.

	HEX WRENCH – T1	QTY 1
	SCREW – H5	QTY 4

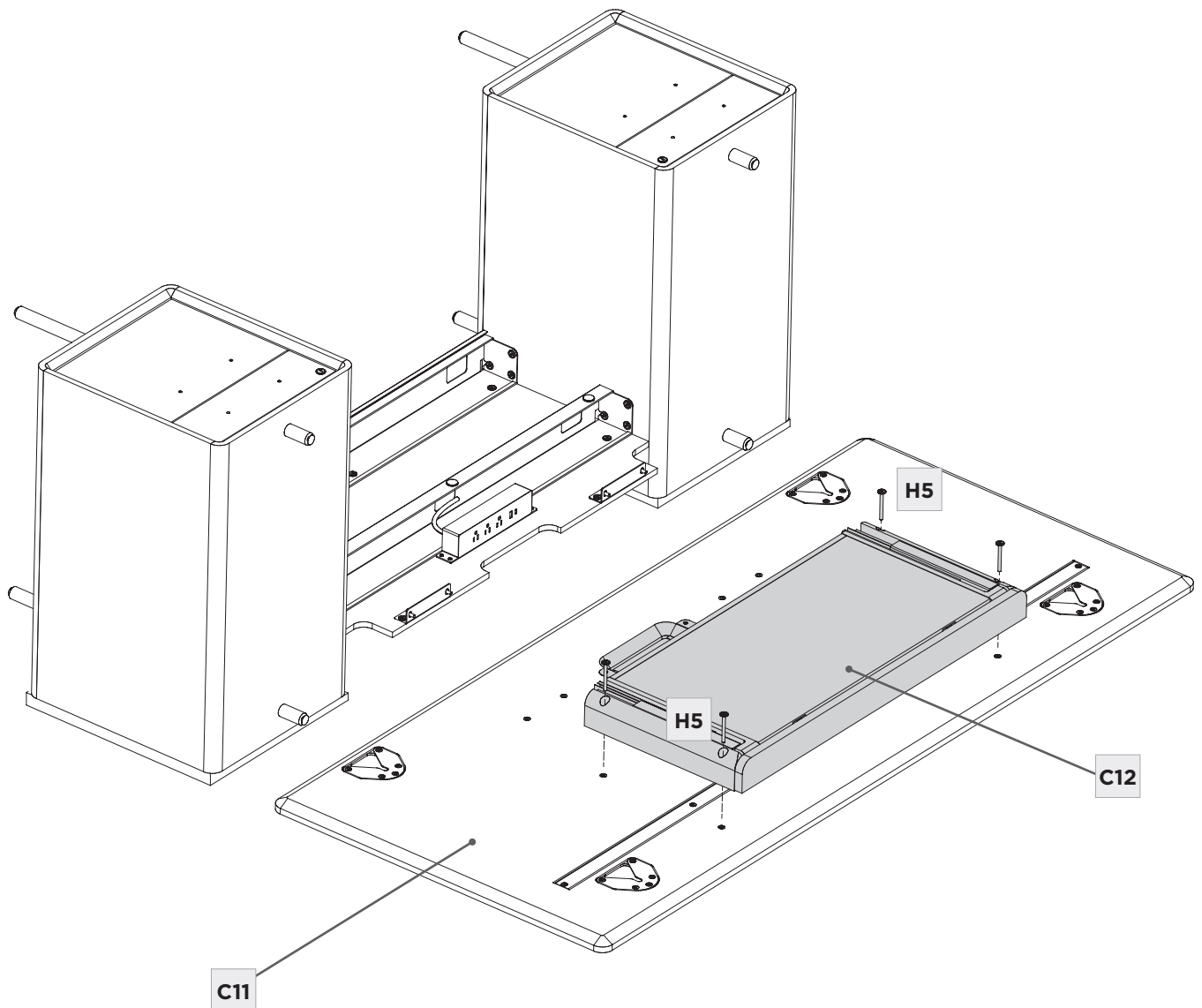



STEP 7. ATTACH TOP PANEL TO CABINET

ASSEMBLY

With the help of another person, carefully lift the **Top Panel (C11)** and hook the Connection Plates onto the **Standoffs (C6)**. Ensure each Standoff is properly seated in each Connection Plate.

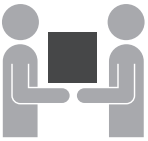
Insert **4 Screws (H1)** into each **Modesty Panel Bracket (C4)**. Tighten with **Hex Wrench (T1)**.



	HEX WRENCH – T1	QTY 1
	SCREW – H1	QTY 4

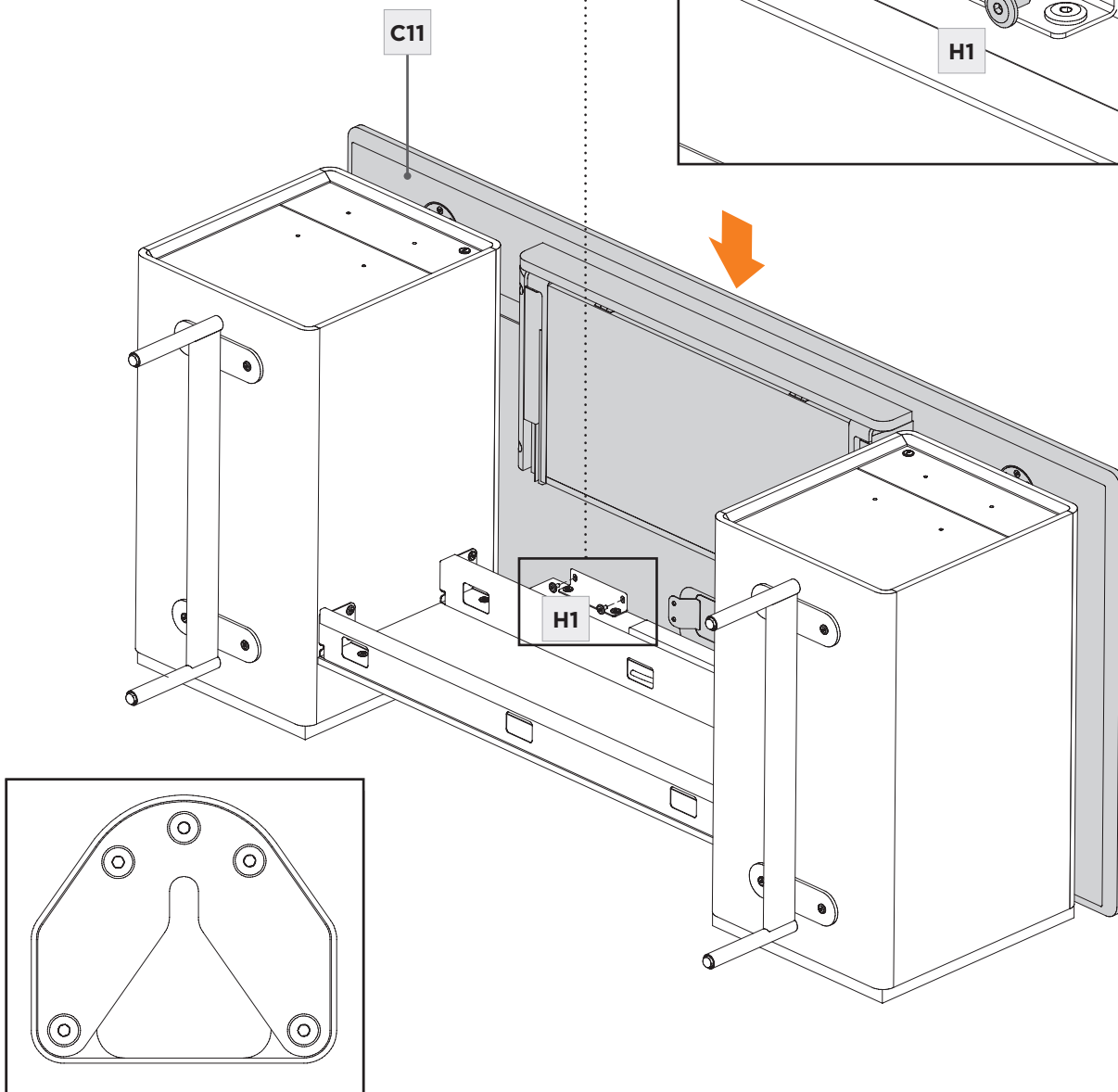
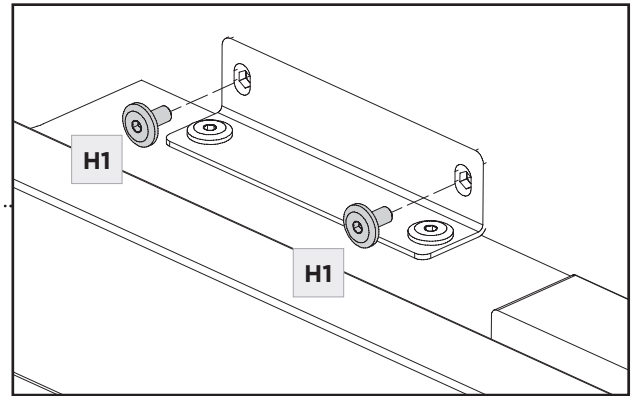

Detail of Connection Plate

ASSEMBLY

STEP 8. ATTACH DRAWER PULLS, TRAY, & FILE HANGING BARS

With the help of another person, carefully flip the desk onto its feet. Open each drawer and install the **4 Drawer Pulls (C14)** using **8 Screws (H6)**. Tighten with **Phillips Screwdriver (not included)**.

Place the **Grommet Lid (C15)** in the Grommet Hole.

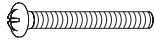
	NOT INCLUDED PHILLIPS SCREWDRIVER	QTY 1
	SCREW – H6	QTY 8

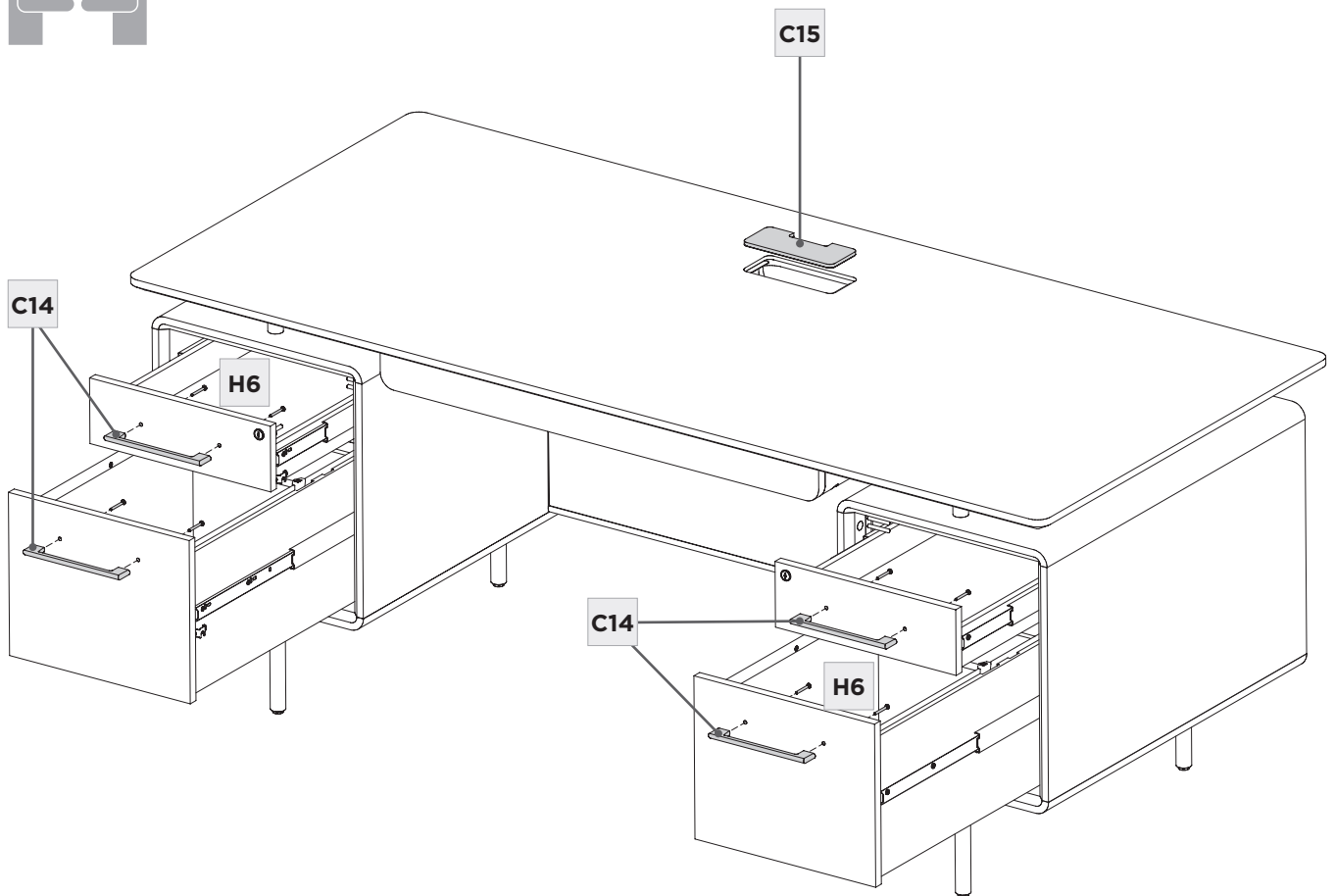

STEP 9. INSTALL MODESTY PANEL

ASSEMBLY

After arranging any wires to your liking, install the **Inner Modesty Panel (C13)**.

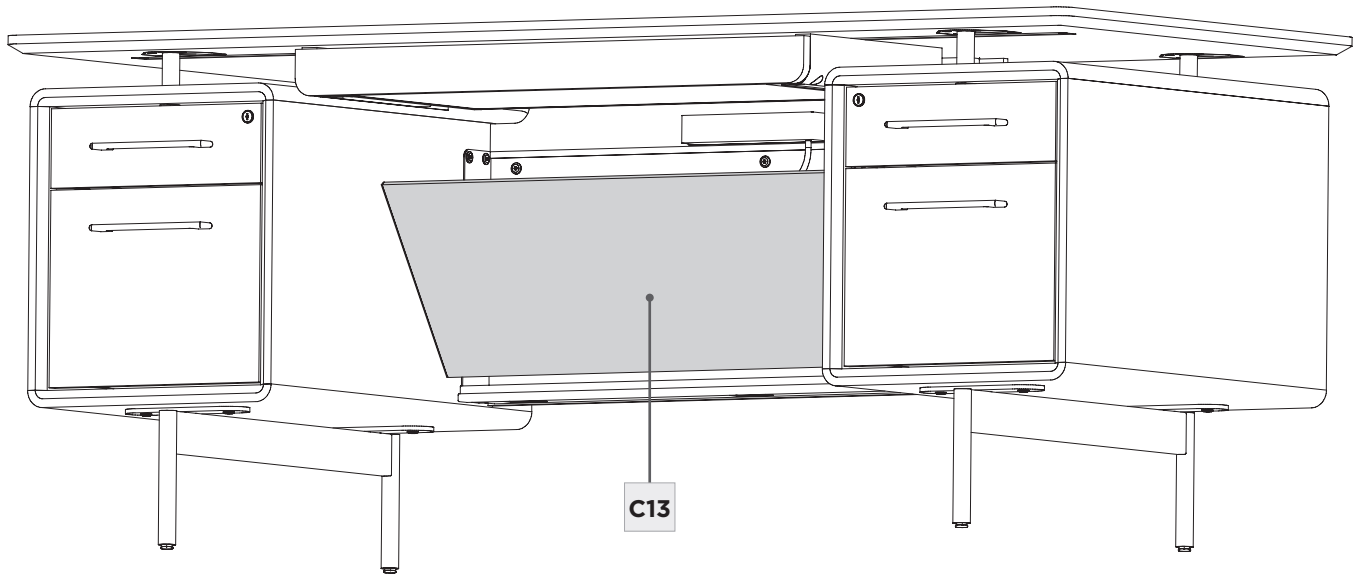

STEP 9. INSTALL MODESTY PANEL

ASSEMBLY

Press the **File Clips (C18)** onto the ends of the **File Hanging Bars (C17)**. Place the **Drawer Tray (C16)** and **File Hanging Bars** in the drawers where desired.

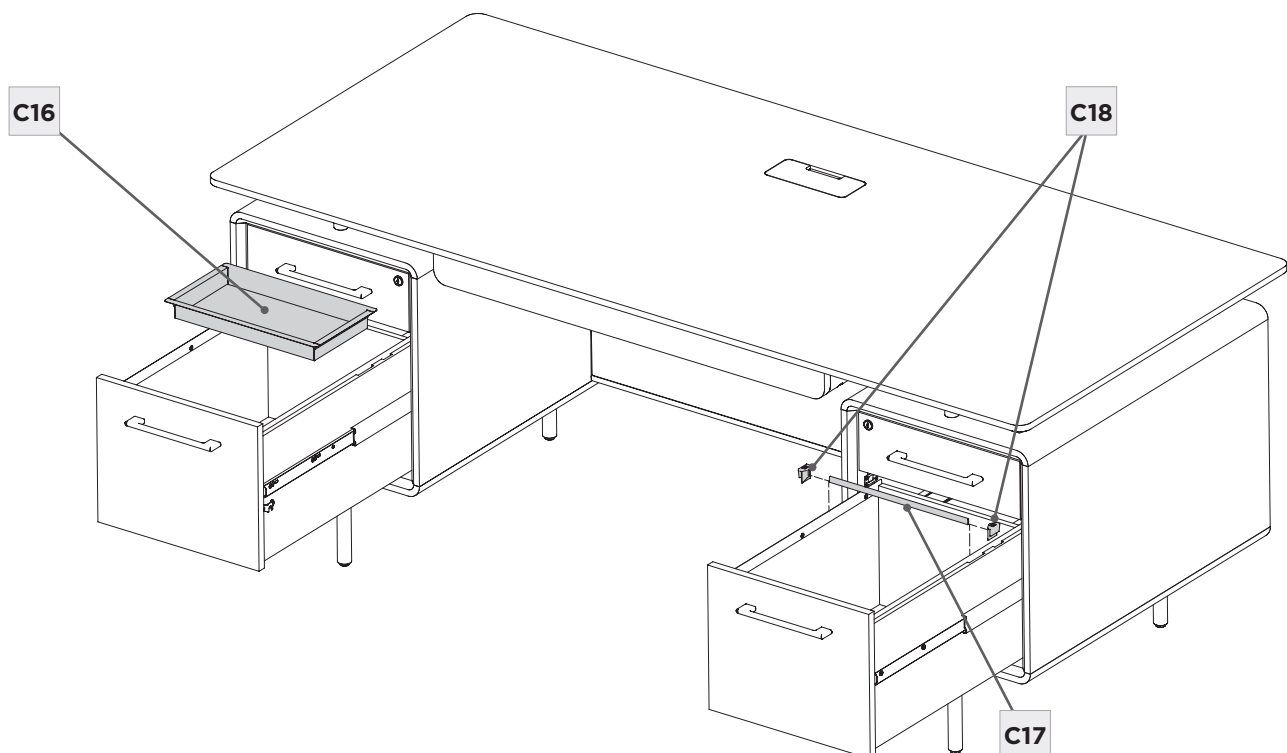

Once the unit is completely assembled and in its final position, adjust the levelers using **Leveler Wrench (T2)**. Using a level (not provided), level your cabinet first side to side and then front to back. If your cabinet is on carpeting, check your front to back level after loading the cabinet and opening the heaviest drawers. This will ensure the cabinet remains level during operation and reduce the risk of tip-over.

	PART/DESCRIPTION	QTY
	LEVELER WRENCH – T2	1

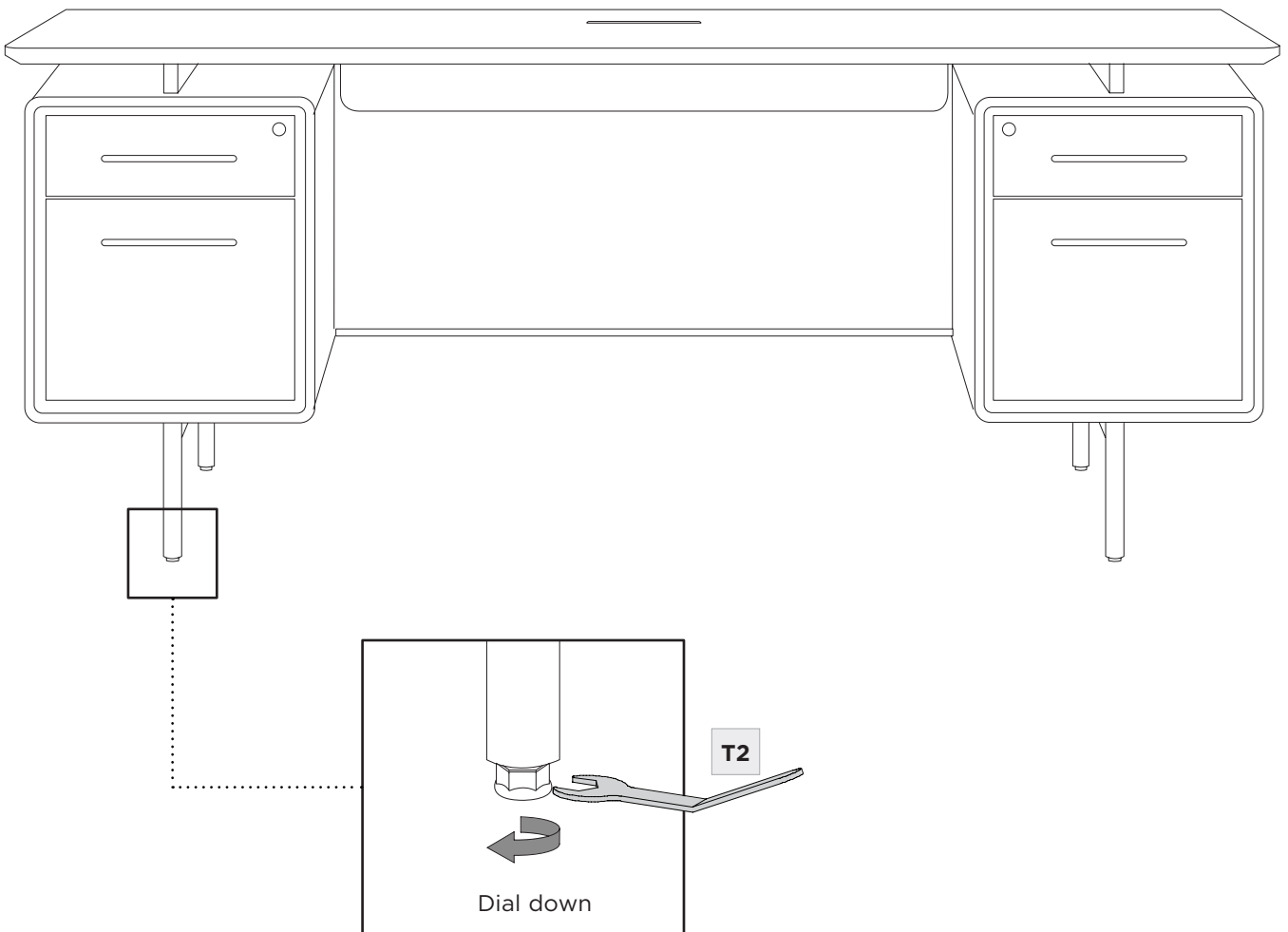

Your BDI furniture has been constructed with the finest materials, carefully manufactured, and designed to last a lifetime. Regular furniture care will prolong your enjoyment and keep it looking its best. Here are some general tips for taking care of BDI furniture. Your surfaces may vary.

GLASS

Glass surfaces are maintained using household glass cleaner and a paper towel or cloth.

SATIN-ETCHED GLASS

This uniquely smooth-to-the-touch glass surface can be regularly maintained using household glass cleaner and a paper towel or cloth.

A 'Magic Eraser' removes minor scratches or scuffs not eliminated using a paper towel or cloth. 'Magic Eraser' is a melamine foam product available at any grocery store or home improvement center. Dampen the entire glass surface and the Magic Eraser, then rub the whole surface in broad, even strokes using moderate pressure. Clean and dry the surface with a paper towel. Check for results and repeat as necessary. Any scratches or scuffing not eliminated by one of the above methods can often be addressed by 'refreshing' the glass. This process should not be required more than once per 6-12 months. See this brief video for the simple method: www.bdiusa.com/glass

WOOD

Wood surfaces should be cleaned with a slightly damp (not saturated) cloth or paper towel. Do not use glass cleaner on wood. If moisture remains, dry the surface with another cloth. If needed, a gentle, non-abrasive cleanser may be used, but wipe away all cleaner residue and dry the surface with a cloth.

BDI's wood finishes feature natural hardwood solids and veneers. Wood is a product of nature and—unlike man-made materials that can be manufactured to strict and consistent specifications—has natural imperfections that are part of its appeal and character. Every piece of wood differs from every other, even when coming from the very same tree. As such, grain, texture, and tone variation should be expected from one panel or piece of furniture to the next.

While BDI's stained wood finishes are stable in tone & appearance, all finishes are subject to some degree of discoloration with prolonged exposure to direct sunlight. Please avoid positioning your BDI cabinet in any area with ample direct sunlight. To learn more about the features of natural wood, visit www.bdiusa.com/wood

METAL, PORCELAIN, & PAINTED SURFACES

Surfaces should be cleaned with a slightly damp (not saturated) cloth or paper towel. If moisture remains, dry the surface with another cloth. If needed, a gentle, non-abrasive cleanser may be used, but be sure to wipe away all cleaner residue and dry the surface with a cloth.

WARRANTY

BDI warrants to the original purchaser that for the below-stated warranty term, BDI will replace any product, part, or component covered by this warranty that fails under normal use as a result of a defect in material or workmanship. The decision to replace a complete product versus the part or component in question will be at BDI's sole discretion.

Residential Use: BDI Furnishings carry warranty coverage for three (3) years from the date of product delivery, as shown on your sales receipt/documentation. Select chairs carry coverage for five (5) years from the date of product delivery.

Commercial Use: BDI Furnishings carry warranty coverage for one (1) year from the date of product delivery, as shown on your sales receipt/documentation. Select chairs carry coverage for five (5) years from the date of the product delivery, based on an 8-hour daily use pattern.

BDI reserves the right to refine or update its warranty from time to time. See the complete and latest warranty document at www.bdiusa.com/warranty.

PRODUCT REGISTRATION

Registering your new BDI product allows us to send you important product updates, service information, and helpful hints related to your BDI products.

Register today, and you will be **entered to win free a BINK table** from BDI: www.bdiusa.com/register

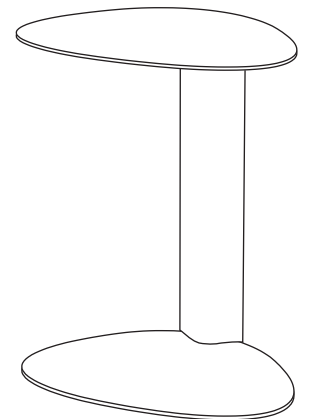

BDIUSA.COM

These distinctive product configurations are protected by US and international patents, trade dress, and/or copyright laws. LINQ & BDI are trademarks of Becker Designed, Inc. All rights reserved. ©2024, BDI | V.02.07.2024

Made in Vietnam.