

ZML-M90CS  
ZML-M90CG  
ZML-E42CS  
ZML-E42CG

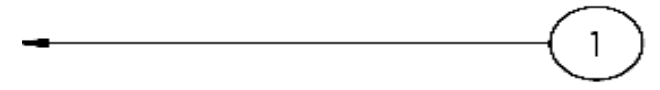

1

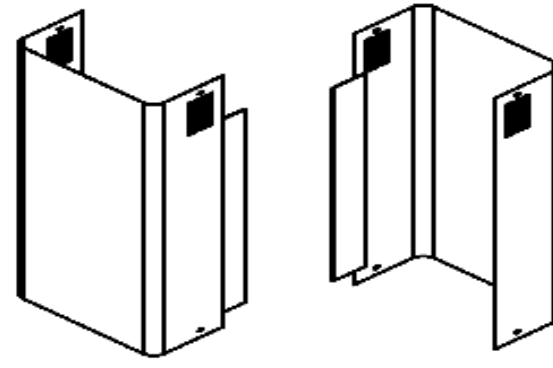
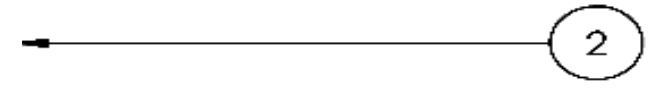
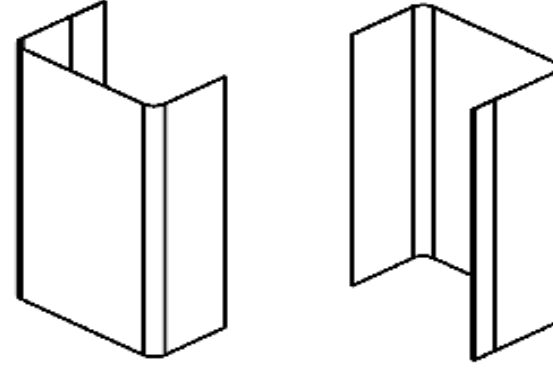

2

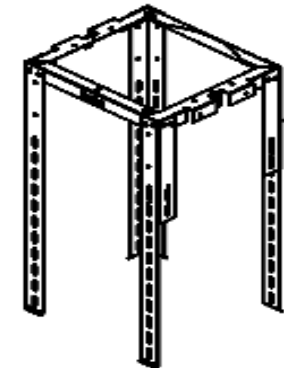

3

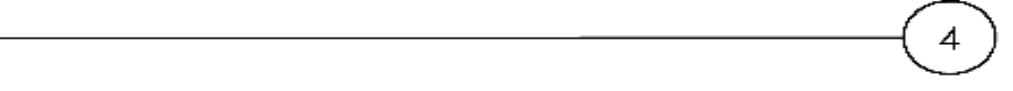
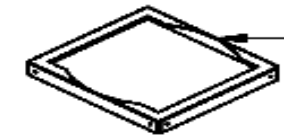

4

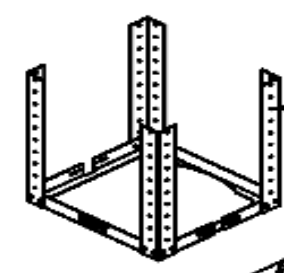

5



6

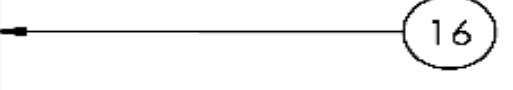
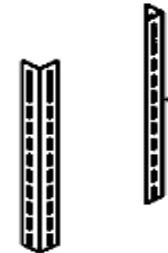
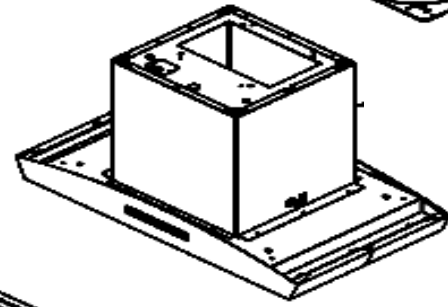

16

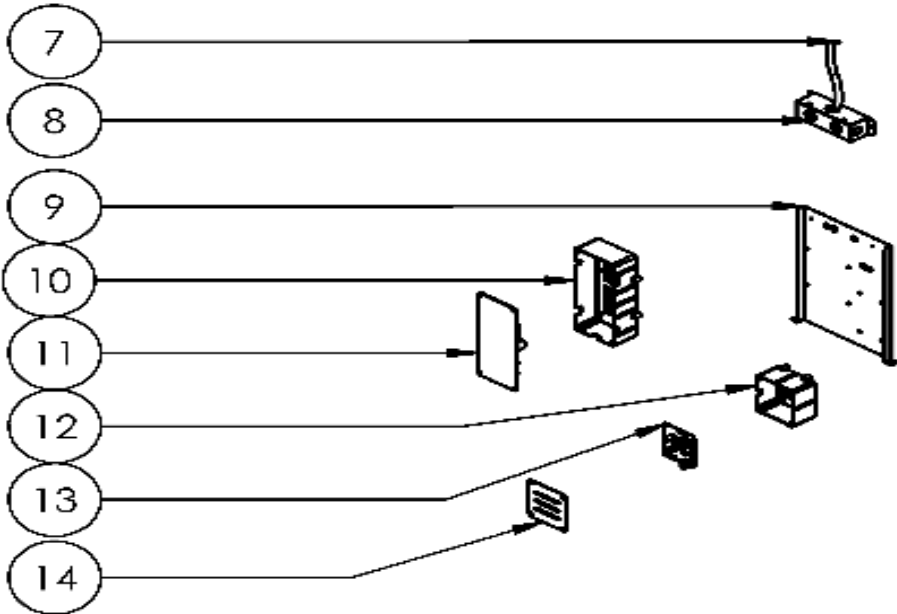

7

8

9

10

11

12

13

14

17

18

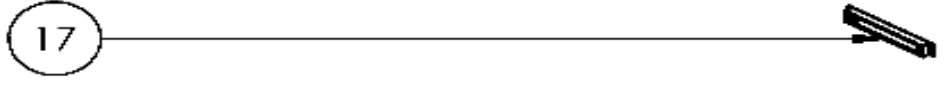
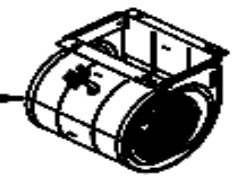

17

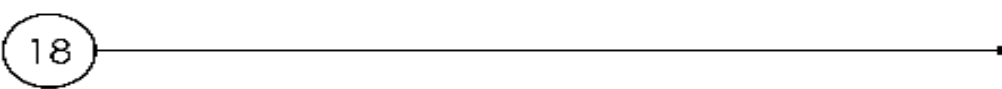

18

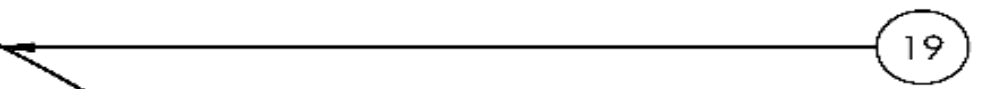
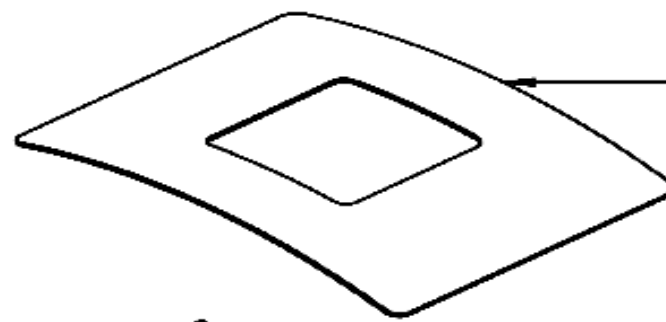

19

23

24

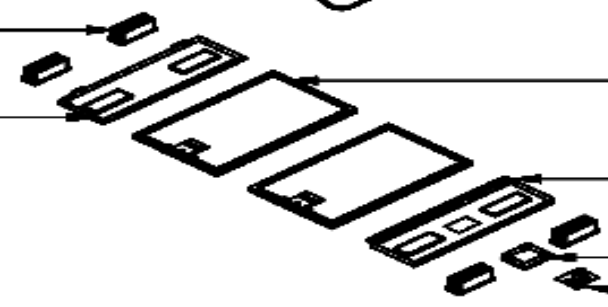

20

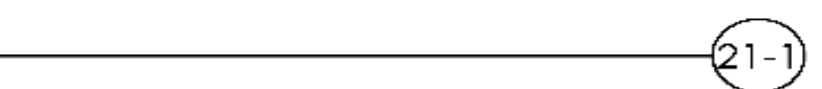

21-1

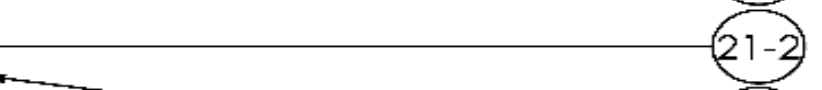

21-2

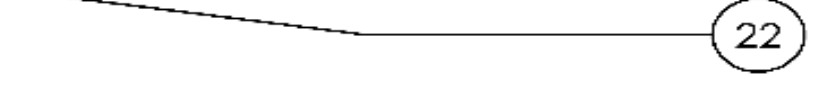

22

# ZEPHYR

# Milano Is.

## ZML-M90CS/G, ZML-E42CS/G

Ref #	Part #	Description	Qty.
1	50050164	Upper Duct Cover	2
2	50050165	Lower Duct Cover	2
3	54110103	Upper Support Frame	1
4	54110081	Support Frame Bracket	1
5	54110104	Lower Support Frame	1
6	54050080	8 Inch Round Collar w/Damper	1
7	11030143	Electrical Wire	1
8	56200080	Electrical Box	1
9	54140307	Electrical Bracket	1
10	54200019	Component Box	1
11	11010130	Main Control Board	1
12	56200079	LED PCB Housing	1
13	11010132	LED Control Board	1
14	56210066	Component Box Cover	1
16	54120011	Support Frame Bracket	2
17	11000149	Switch Assembly	1
18	12120086	Motor	1
19	50300102	Canopy, ZML-M90CG	1
19	50300100	Canopy, ZML-M90CS	1
19	50300103	Canopy, ZML-E42CG	1
19	50300101	Canopy, ZML-E42CS	1
20	50200043	Aluminum Mesh Filter	2
21-1	50110314	Light Panel w/WiFi Cover	1
21-2	52170082	WiFi Cover	1
22	11010131	WiFi Control Board	1
23	Z0B0047	LumiLight LED, DC, 6W	4
24	50110315	Light Panel	1
25	05000125	Hardware Packet	1